

AVX100Z BL Zone I Whisper Quiet Fan - Specification Sheet



Technical Details

Construction	Impact resistant ABS thermoplastic
Rating	220-240V ~50Hz~AC 7.5W
IP Rating	IP45
Class	Double Insulated <input type="checkbox"/>
Motor	Single-phase induction motor with pre-oiled bearings; All with thermal overload protection.
Maximum Operating Temperature	40°C
Approvals	UKCA, CE, ErP 2018
Warranty	5 Years Exchange
Country of Origin	UK
Manufacturer	Addvent

Performance Details

Model	V	W	A	SFP (w/l/s)	m ³ / Hr	l/s	dB(A) @ 2m
Hi Speed	230	7.5	0.049	0.278	97	27	25

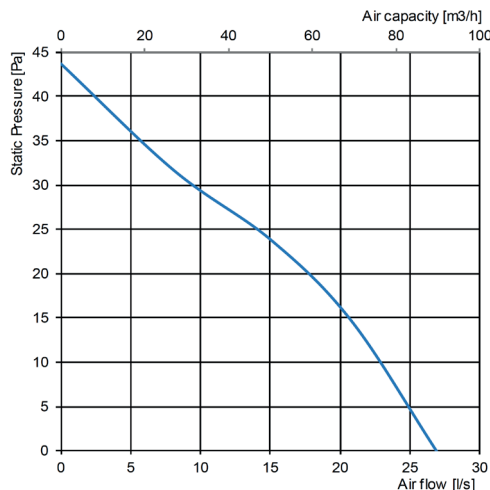

Key Features

- Specially designed mixed-flow impeller ensures high airflow and low noise level.
 - Casing and impeller made of quality durable UVresistant plastic.
 - Built in backdraft damper.
 - Suitable for installing within bathroom zones I and 2.*
 - Complies with part L and part F of the building regulations.
 - Low energy consumption: down to 7.5w (SFP 0.278w/l/s).
 - Built-in anti-vibration mounting to further reduce noise.
 - Available in black
 - Standard, timer, humidity control options.
 - 5 year warranty.
- * Must be fitted in accordance to the 18th edition wiring regulations

Models

Model No.	Product Description
AVX100ZTBL	Zone I Whisper Quiet Fan With Timer Black
AVX100ZSBL	Zone I Whisper Quiet Fan Standard Black
AVX100ZHBL	Zone I Whisper Quiet Fan With Humidity Timer Black

Options

Model Modification	S	T	H
Standard	●		
Run-On Timer		●	
Humidity sensor		●	●

Standard	No controls
Run-on Timer (T)	Run-on timer - adjustable from 2 to 30 minutes
Humidity Sensor (H)	Humidity sensor - adjustable from 60% to 90% RH.

LinkedIn



THE TOTAL VENTILATION SOLUTION

Tel: +44 (0)117 938 6402

Email: enquiries@addvent.co.uk

Installation Information

The AVX100Z BL Fans are Wall & Ceiling mountable

Additional Information

Wall Hole Size 103mmØ

Dimensions

Dimensions MM	D	B	H	L	LI
AVX100ZT/S/H BL	99	158	136	81	26

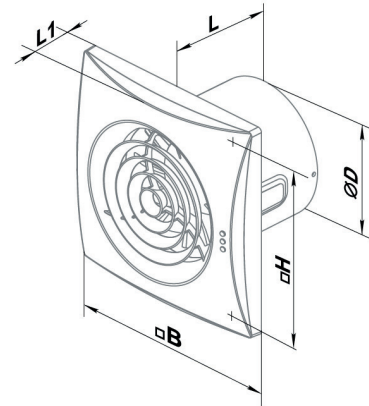

THE TOTAL VENTILATION SOLUTION

Tel: **+44 (0)117 938 6402**

Email: enquiries@addvent.co.uk