

## PMCS6 CEILING SENSOR

- ① Main Body
- ② Lens

### INTRODUCTION

The use of occupancy detectors in commercial and industrial applications can significantly reduce energy usage lessening both energy costs and helping the environment.

The PMCS6 360 degrees MICROSENSITIVE surface mount OCCUPANCY DETECTOR uses passive infrared sensors (PIR) which react to changes in temperature emitted by the slight motion of persons or objects passing through its detection area. The PIR sensor automatically operates the connected load when an area is occupied. After a preset time on non-activation (when an area is vacated) the load will be switched off. In addition the built in photocell takes natural light (daylight) into account when determining its activation.

**Note :** Read this entire manual before you start to install the system.

### SAFETY PRECAUTIONS

- Do not install where it may be possible for water to access the fitting.
- Be sure to switch off power source before installing.
- Make sure that the power wiring comes from circuit with an external miniature circuit breaker not higher than 10A for the short circuit protection or a suitable fuse.

### IMPORTANT

Installation must be performed by a skilled/competent person who is familiar with the appropriate standards and technical requirements of the appliance and its proper installation.

Before proceeding with the installation, TURN OFF THE POWER TO THE LIGHTING CIRCUIT AT THE CIRCUIT BREAKER OR FUSE BOX TO AVOID ELECTRICAL SHOCK.

### CHOOSING A MOUNTING LOCATION

- Avoid aiming the motion sensor at heating vents, air conditioners or objects which may change temperature rapidly.
- Do not allow sunlight to fall directly on the front of unit.
- The motion sensor is more sensitive to objects moving across its field of view. It is less sensitive to an object moving directly towards the sensor head. (FIGURE 1)

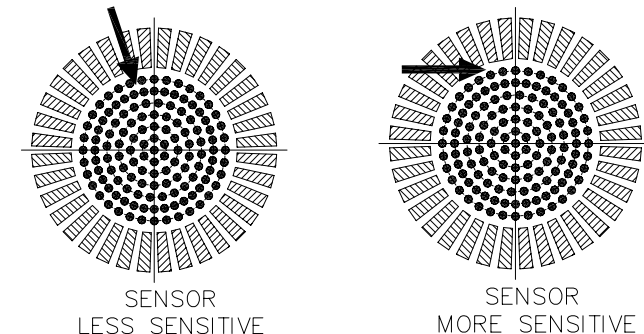

FIGURE 1

## INSTALLATION

The unit has a sensing angle of 360°. It detects micro movement within a 3.5m RADIUS (sitting zone) and can detect general movement up to 5M RADIUS at a mounting height of 2.5 meters. (FIGURE 2)

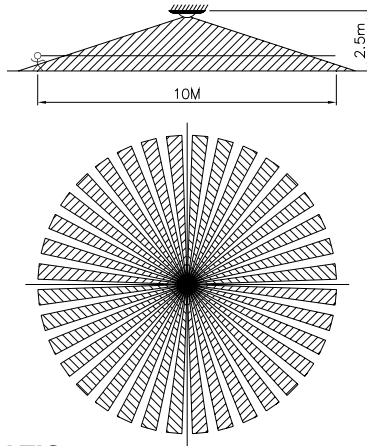

FIGURE 2

### SCHEMATIC

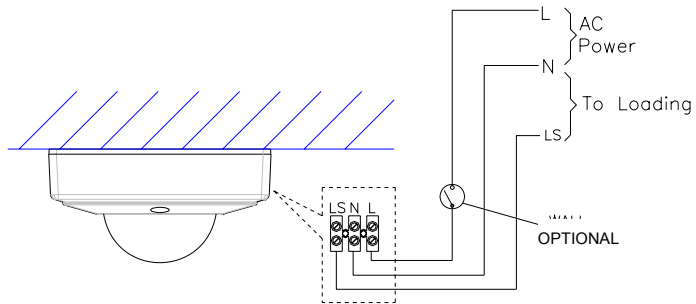

FIGURE 3

## WIRING INSTRUCTION

- (1) Switch off the power source or wall switch.
- (2) Strip approximately 6-8mm insulating part of the wires from the power cord.
- (3) Connect the BROWN wire (Live wire) of power cord to the terminal block "L" mark.

Connect the BLUE wire (Neutral wire) of power cord to the terminal block "N" mark.

Connect the BROWN wire of lamp wire to the terminal block "LS" mark. (FIGURE 4)

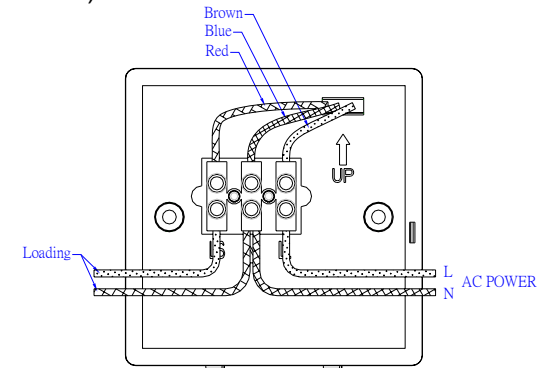

FIGURE 4

- (4) Fit the main body to the wall box of the ceiling and secure it with two fixing screws provided. (FIGURE 5)

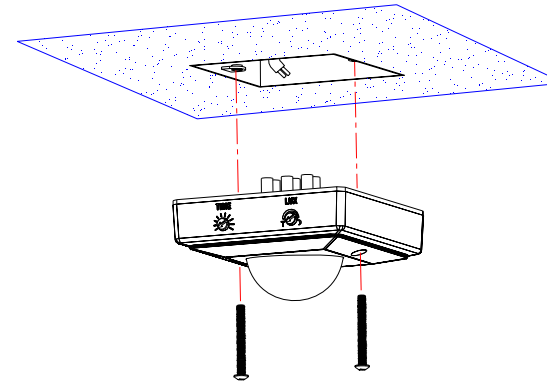

FIGURE 5

The product is also designed to fit a standard UK spec pattress box.

## SETTING THE LIGHTING SYSTEM

### (1) TEST MODE

- Turn the Lux control and the Time control counter-clockwise to the edge-the TEST position. (FIGURE 6)

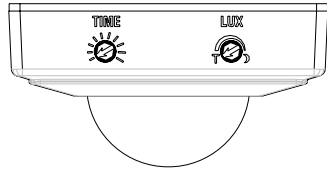

FIGURE 6

- Turn the power supply or wall switch on, the light will turn on immediately and wait for about 1 minute to warm up the unit. After warm-up time is expired and the light goes off, you may make a walk test and the light will turn on. This confirms that the wiring was done properly and that the light is working.
- Walk through the coverage area. The light will turn on for about 5 seconds when motion is detected and turn off shortly after the area is fully vacated.

## (2) SETTINGS

### ■ TIME ADJUSTMENT

The TIME adjustment controls how long the light will stay on after motion has been detected.

There are 10 selectable time settings including test ( 3 seconds ) 10, 20, 40, 80, 160 seconds and 5, 10, 20, 40 minutes. Adjust the time control knob clockwise to increase the turn-off time ( 40 minutes maximum ) or counter-clockwise to decrease the turn-off time ( 3 seconds minimum ) ( FIGURE 7 )

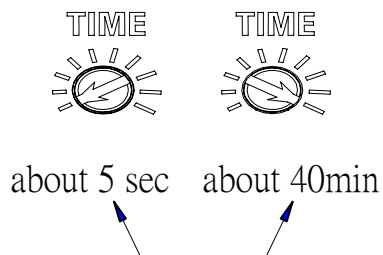

FIGURE 7

### ■ LUX ADJUSTMENT

The LUX adjustment determines at what light level the light will start operating when you set the sensor to the AUTO mode.

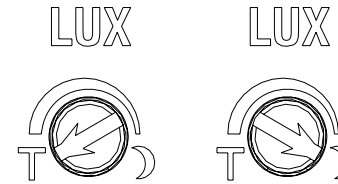

FIGURE 8

Provisionally turn the LUX Control Knob to the edge clockwise at the moon (dusk) position. (FIGURE 8) In this provisional setting mode, the Motion Sensor remains inactive during daylight. At dusk when you find it is the LUX level you desired for operation, simply set the LUX control knob to the position that you tried satisfactorily.

## OPERATION

### ■ Automatic Operation

When the sensor detects motion, the light automatically turns on. The built-in photocell turns the sensor off and on according to the light level selected by the LUX adjustment.

## TROUBLESHOOTING

### Light does not turn on

- Confirm that you have made a correct "wiring connection".
- Make sure that the bulbs have not burned out..

### Light remains on

- Make sure the wiring connection is correct.
- Check if the TIME setting is correct.

SPECIFICATIONS	
Power Requirement	AC 230V / 50Hz
Lighting Load	Max. Incandescent: 2000W Max. Halogen: 2000W Max. Fluorescent / Cos $\Theta$ =0.5: 1500W, For quantity of fittings refer table Max CFL/ PL/ LED : 10 pieces
Detection Angle	360° MICRO DETECTION
Detection Distance	Micro movement: Up to 3.5m radius at 25°C at 2.5m Height
	General movement: Up to 5m radius at 25°C at 2.5m Height
Mounting Height	Recommended 2.2 ~ 3m Ceiling Mount
Wall Switch Control	Auto/Off
Time Adjustment	Approx. 5 seconds to 40 minutes (5, 10, 20, 40, 80, 160 second & 5, 10, 20, 40 minute)
Lux Adjustment	Approx. 30 ~ 200 Lux & test mode
Warm Up Time	About 1 min
Protection Class	Class II
Protection Degree	IP44
Safety	CE

E-Matic Energy Management Solutions,  
4 Arkwright Court, Fylde Industrial Estate,  
Blackpool, Lancashire, FY4 5DR.  
Tel: 01253 791888, Fax: 01253 791887,  
Web site: [www.e-matic.co.uk](http://www.e-matic.co.uk)  
Email: [enquiries@e-matic.co.uk](mailto:enquiries@e-matic.co.uk)



**Due to our policy of continuous improvement we reserve the right to change specification without prior notice.**

**Errors and omissions excepted. These instructions have been carefully checked prior to publication. However, no responsibility can be accepted by E-Matic for any misinterpretation of these instructions.**

**Warning:**

Do not dispose of electrical appliances as unsorted municipal waste, use separate collection facilities.

Contact your local government for information regarding the collection systems available.

If electrical appliances are disposed of in landfills or dumps, hazardous substances can leak into the groundwater and get into the food chain, damaging your health and well-being.

Model	PMCS6
Lighting Maximum Load For Incandescent (Cos $\theta$ =1)	2000W/8A(@240VAC)
Lighting Maximum Load For Halogen (Cos $\theta$ =1)	2000W/8A(@240VAC)
Lighting Maximum Load For Fluorescent T8 (Cos $\theta$ =0.5)	1500W/12A(@240VAC)
Lighting Maximum Load For Fluorescent T5 (Cos $\theta$ ≥0.9)	1500W/6.9A(@240VAC)
Lighting Load (number of fittings) for Fluorescent T5	<p>Conditions : Maximum quantity of ballasts and lamps listed below;</p> <p>Ballast Q'ty x (Lamp Q'ty x Watt)</p> <p>22x(4x14W);</p> <p>20x(2x21W);</p> <p>20x(2x24W);</p> <p>15x(2x28W);</p> <p>15x(2x35W);</p> <p>12x(2x39W);</p> <p>12x(2x49W);</p> <p>10x(2x54W);</p> <p>10x(1x80W);</p>

Lighting Load (Number of fittings) for CFL & PL (Setup Conditions)	<p>Conditions : Maximum quantity of lamps/wattage listed below;</p> <p>Lamp Q'ty x Watt</p> <p>10x9W</p> <p>10x11W or 10x13W or 10x19W ;</p> <p>10x20W or 10x23W ;</p> <p>10x24W or 10x26W or 10x27W ;</p> <p>10x32W or 10x36W or 10x38W ;</p> <p>10x42W or 10x50W or 10x55W ;</p> <p>10x80W:</p>
Lighting Load For LED	<p>10 Qty parallel connection</p> <p>200W total (Max.)</p>