

CHALLENGER

YOUR PARTNER IN A MORE SECURE FUTURE

SOLAR PIR SENSOR LIGHT

MODEL: SLFS

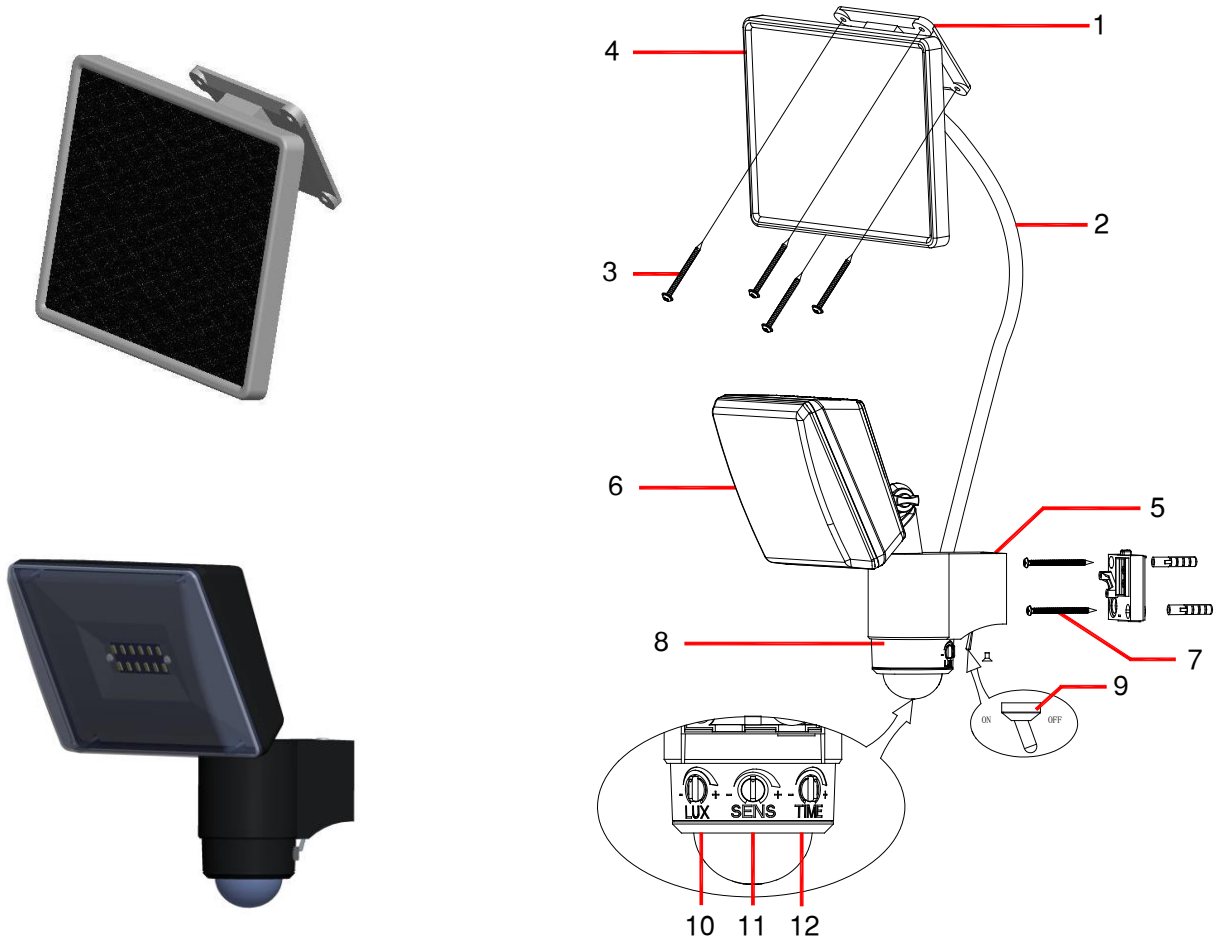

PARTS LIST

- | | |
|---|----------------------------------|
| 1. Mounting Bracket | 2. Adjustment Support |
| 3. Solar Cell Mounting Screws (X 4) | 2. Solar Cable |
| 5. Main Battery Unit | 4. Solar Cell |
| 7. Main Housing Mounting Screws (X 2) | 6. Transparent Light Cover |
| 9. AUTO / OFF Switch | 8. PIR Sensor |
| 11. Sensitivity Adjusting Knob | 10. Lux Control Adjusting Knob |
| | 12. Duration Time Adjusting Knob |

Important: Please ensure that you charge the solar lights in maximum sunlight for a period of up to 3 days before switching on the lights, in order that the lights work on a full charge

■ HOW TO DETERMINE WHERE TO MOUNT YOUR SOLAR PIR SENSOR LIGHT

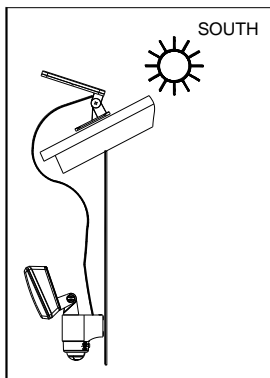
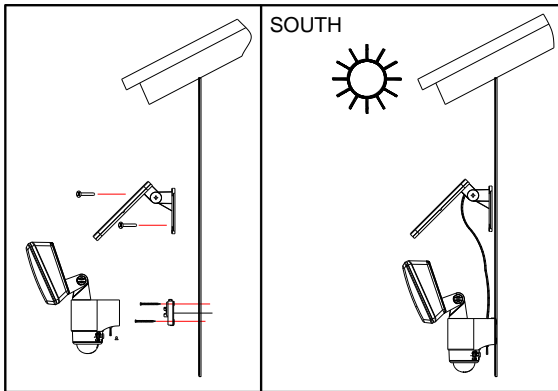

Please be noted that: **DIRECT SUNLIGHT** is important for the operation of SOLAR PIR SENSOR LIGHT. The more direct sunlight the solar cell receives in daytime, the longer the light will operate.

■ Main Unit:

The main unit contains the lamp (12pcs 0.5W LED), motion sensor and battery (18650 Lithium Rechargeable battery, 3.7V, 2200mAh). When determining where to mount this unit, please consider that the motion sensor with detection scope of max.6meters (in front of the light) and about 130° (horizontal) at 25°C ambient temperature.

To mount the unit vertically as a security light, attach the unit to a solid surface as shown in figure. Use the two screws provided in the package (#7 on parts list).

■ Solar Cell:

The solar cell is the main power source for the SOLAR PIR SENSOR LIGHT. It converts the sunlight's energy into electricity that charges the

battery in main unit. It requires **DIRECT SUNLIGHT** onto the surface of solar cell for as long as possible during the daytime.

Use the four screws provided in the package (#3 on parts list) to mount the solar cell unit onto a solid surface. Make sure it is fixed into the solid surface.

You can adjust the angle of the solar cell by moving the adjustment bracket to the appropriate hook on the mounting base. It should face as much **DIRECT SUNLIGHT** as possible during the daytime.

At last route the solar cell's power cord to the main unit and plug it into the side hole for solar cell.

Important: if the main unit is mounted horizontally, it must be mounted in a covered area so rain water can not get into the unit through the exposed vents.

■ FINAL ADJUSTMENT AND START-UP

After you successfully installed your SOLAR PIR SENSOR LIGHT, you are almost ready for carefree operation with a few final steps:

Initial 3-days Charge:

On the main unit there is a switch with 2 positions:

● OFF ● ON

ON —

Position for normal operation

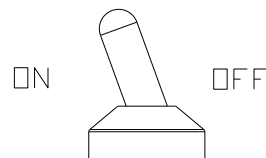

OFF ---

- 1) Position for delivery or long periods of non-use
- 2) Position for initial 3-days charge before first adjustment and use.

Then, turn the slide switch to OFF position. The solar cell will charge the battery without activating the unit.

Leave the switch in this position for 3 sunny days to ensure that the battery has a full charge for motion sensor adjustment and normal operation.

■ HOW TO ADJUST THE MOTION SENSOR

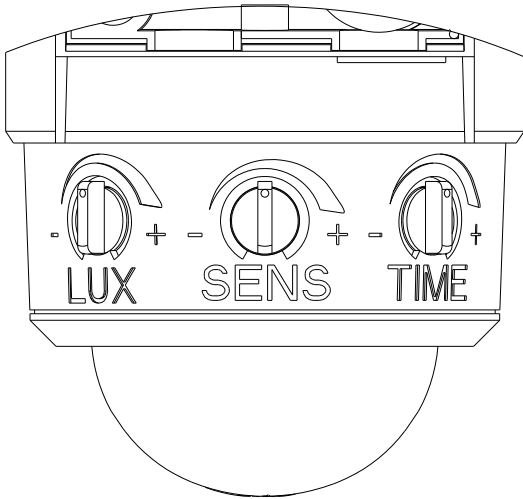

After the initial 3-days charge, turn the switch to AUTO position.

On the motion sensor there are three adjusting knobs: **TIME / SENS / LUX**

1) **TIME** --- Duration time: For how long you wish the light to run after motion is detected in the field, the duration time is from 10 seconds to 1 minute adjustable.

Note: Once the light is activated by the PIR sensor, any subsequent detection will restart the timed period again from the beginning.

2) **SENS** – Sensitivity adjustment: The sensitivity of motion sensor can be affected by environmental temperature. The more sensitivity will be for PIR sensor in the lower environmental temperature. So you can adjust the SENS knob to compensate the change of sensitivity affected by environment temperature.

3) **LUX** – Lux control level: The Lux control module has a built-in sensing device (photocell) that detects daylight and darkness. (☀) position denotes that the lighting will be turned on by PIR during day and night, (☾) position denotes that the lighting will be turned on by PIR only at night. You can set desired level to run the unit by adjusting the LUX knob.

Note: If, in daily position, the unit turns on when it

is too light outside, turn the control towards (☾). however, if the light is not activating during nighttime because of a street light or bright house light, turn this control towards (☀).

Walking-test:

Point the motion sensor to face the area you want to detect motion in and set the TIME knob to minimum (-) position and LUX knob to “light” (☀) position. Walking slowly in its detection area, the sensor can detect moving invisible infra-red radiation given off by a human body and then turn on the light. Test the coverage of the area by walking slowly around until not to switch on the light.

ADJUSTMENT OF THE LAMP HOUSING:

Point the lamp housing to face the area you wish to illuminate.

■ BATTERY REPLACEMENT

Caution: When replacing the battery, the slide switch on the main unit must be in the **OFF** position.

The battery in your SOLAR PIR SENSOR LIGHT is designed to last for about 1 year. When it becomes necessary to replace the battery, you can obtain a replacement from your distributor.

The old battery can be replaced by first removing the screws on the main unit which hold the main unit on the wall mounting cover. Carefully replace the batteries in the battery box. Carefully remove the battery from its compartment and replace by reversing this procedure.

(Caution: Make sure the (+) and (-) are attached correctly to the appropriate (+) and (-) battery terminals. Serious damage to the unit may result if they are connected backwards.)

It is important to dispose of the battery in an environmentally conscious manner. Dispose of according to applicable governmental regulations.

■ GENERAL ELECTRICAL AND SAFETY WARNINGS

- 1) The ON/OFF switch on the main unit must be in the OFF position when changing the battery.
- 2) Do not cut the solar cell wire. Discontinue use if the wire becomes frayed or broken.
- 3) Do not immerse components in liquid.
- 4) Do not use any other charge than the single solar charging panel provided with the SOLAR PIR SENSOR LIGHT. This may result in injury or damage to the light and voids any warranty.
- 5) Position so that the cord is securely fastened and will not result in a hazard (such as tripping).
- 6) When changing the battery, be careful of any sharp edges that could cut you or the wires. Do not pull on wires.

■ CLEANING

It is important that the solar panel is kept free of dirt and debris. A dirty solar panel will not allow the battery to fully charge and this will shorten the life of battery and cause the light to malfunction

■ STORAGE

If you wish to store your light indoors for more than two or three days, follow these steps to prevent damage to battery:

1. Turn the switch to OFF position
2. Store the light and solar panel where it can receive some sunlight or room light each day. The battery needs light to maintain a charge during storage
3. During prolonged storage, unit must be fully charge once every four months, for best performance, do not store for prolonged periods.

■ NOTE THE FOLLOWING TROUBLE-SHOOTING:

1. **Symptom:** Light won't activate in normal operation.

Correction: make sure that:

- 1) The main unit switch is the ON position.
- 2) The Lux control is not set too far toward (☾)
- 3) The solar cell is angled so that it gets plenty of direct sunlight for most of day, if not the entire day.

- 4) Battery charge is not too low (charge for 3 sunny days—switch turned to OFF)

2. **Symptom:** Light turns on during the day.

Correction: Make sure that

- 1) The Lux control is not set too far toward (☼)

3. **Symptom:** Light quickly flashes on and off

Correction:

- 1) Low battery (charge for 3 sunny days—switch turned to OFF).

4. **Symptom:** Light is not as bright as normal.

Correction:

- 1) Low battery (charge for 3 sunny days—switch turned to OFF).

Due to our policy of continuous improvement we reserve the right to change specification without prior notice. Errors and omissions excepted. These instructions have been carefully checked prior to publication. However, no responsibility can be accepted by Challenger Security Products for any misinterpretation of these instructions.

Distributed by:

CHALLENGER SECURITY PRODUCTS

10 Sandersons Way, Blackpool, FY4 4NB

Email enquiries.challenger@adivision.co.uk

Website: www.challenger.co.uk

