

# ELLIPSE and KH2

## Electronic Time Lag Switches

### Overview

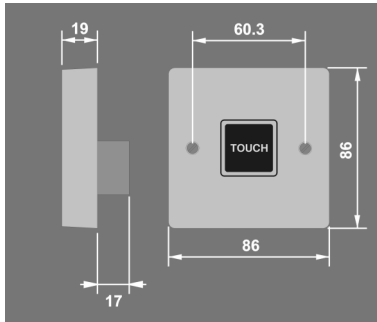
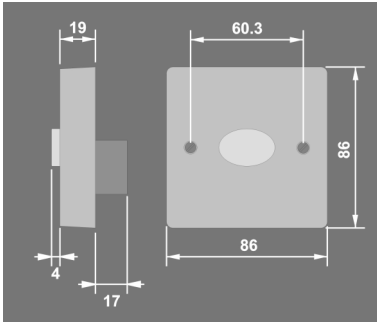

The ELLIPSE and KH2 time lag switches are a quick and effective way to reduce energy consumption for lighting applications. Pressing the button or touch pad brings the lights on; the lights will then switch off automatically after a preset time period has elapsed.

These units do not require a neutral connection, therefore they can be used to replace an existing light switch. The duration of the time delay is set by a thumbwheel on the reverse of the unit.

The ELLIPSE/TN and KH2N have neon illumination to allow the unit to be located in the dark.

Time lag switches can be used in two way and intermediate switching arrangements without any extra wiring.

**ELLIPSE**  
Push button activated time lag switch

**KH2**  
Touch activated time lag switch

### Wiring

#### Conventional Wiring

Wire the units as in diagram 1. When using multiple switch positions see diagram 2.

For two way and intermediate switching follow the diagrams overleaf. Note that as long as each switch position has a *Live* feed and a *Live Out* connection to the load then the switch will be properly wired.

### Installation

**Warning.** This device works at mains potential. Be sure to take care when working with electricity.

1. Make sure the load is connected and in working order.
2. Isolate the mains supply to the circuit at the main consumer unit.
3. Connect the controller via the terminal block. Live supply to the L terminal and the load to the LIVE OUT terminal.
4. Push the override switch to the off position (see diagram).
5. Set the timing range using the thumbwheel. Turn clockwise to increase timing.
6. Screw the unit to the wall and switch the mains supply back on at the distribution board.
7. **Wait 20 seconds before pushing the button**
8. Push the button or touch pad and the lights will come on
9. Wait for the time period and the lights will turn off again.

Diagram 1  
Conventional wiring

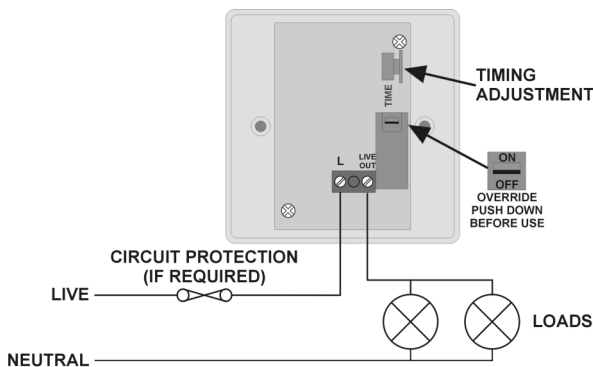
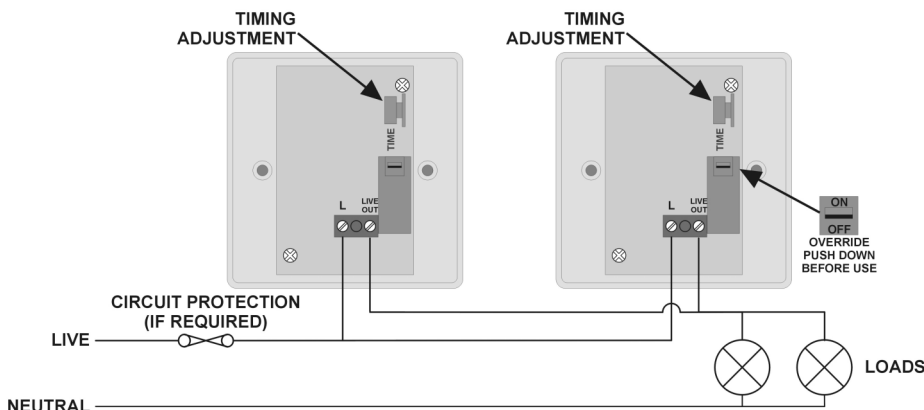

Diagram 2  
Multiple switch locations



## Fault Finding

### LIGHTS DO NOT COME ON

Check to see if the live supply to the circuit is good. Strap across the *L* and *LIVE OUT* terminal to turn the load on.

### LIGHTS DO NOT GO OFF

Ensure that you have waited for the time out period.

If the lights still do not go off then it is likely the unit was not given the 20 seconds start up period on installation. Follow this procedure:

1. Isolate the mains supply to the circuit at the main consumer unit and unscrew the unit from the wall.
2. Push the override switch to the off position.
3. Reapply the mains and wait for 20 seconds.
4. Activate timer as normal.

### LIGHTS FLICKER

Ensure that there are sufficient power factor correction capacitors fitted.

## Specification

### LOAD

10A of lighting including incandescent, fluorescent, compact fluorescent, low voltage (switch primary of transformer).

Fluorescent and compact fluorescent fittings with "switch start" ballasts - 10 ballasts maximum. Power factor correction capacitors must be fitted.

Most fluorescent fittings have power factor correction capacitors fitted. If they are not present the unit may fail to turn off properly or flicker. In this case fit one capacitor per circuit with a minimum value of 1 $\mu$ F for every unit installed. The capacitor should be fitted across switched live and neutral. Note that it is not necessary to fit a capacitor on every fitting. This also applies to fittings controlled with high frequency ballasts and maintained emergency fittings.

*Not suitable for switching contactors*

*Not suitable for SON lighting*

*Not suitable for heating or ventilation loads.*

Please contact our sales department for a suitable alternative product.

**SUPPLY VOLTAGE** 220-240 Volts AC 50 Hz

**TIME OUT PERIOD** 20 seconds to 20 minutes (approximate)

**FIXING METHOD** Surface fixing 25mm deep plastic surface mount moulded box.  
Flush fixing 25mm steel wall box or 32mm deep cavity wall box.

**TERMINAL CAPACITY** 1.5mm<sup>2</sup>

**MATERIAL** Flame retardant ABS

**TYPE** Class 2

**TEMPERATURE** -10°C to 35°C

**CONFORMITY** EMC-89/336/EEC

LVD-73/23/EEC

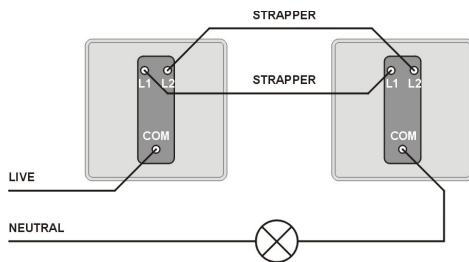

WIRING DIAGRAM FOR TWO WAY SWITCHING

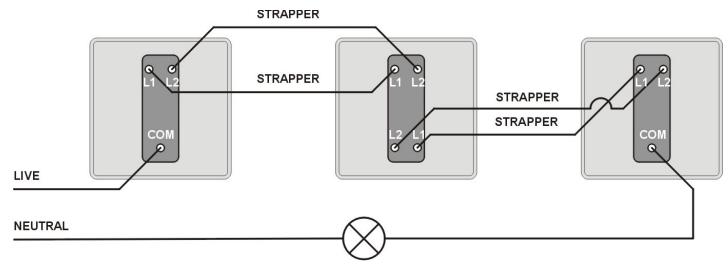

WIRING DIAGRAM FOR TWO WAY AND INTERMEDIATE SWITCHING

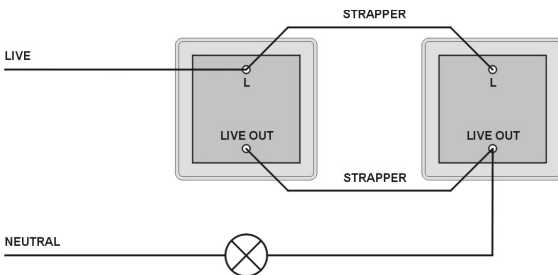

WIRING DIAGRAM FOR TWO WAY SWITCHING USING TIME LAG SWITCHES

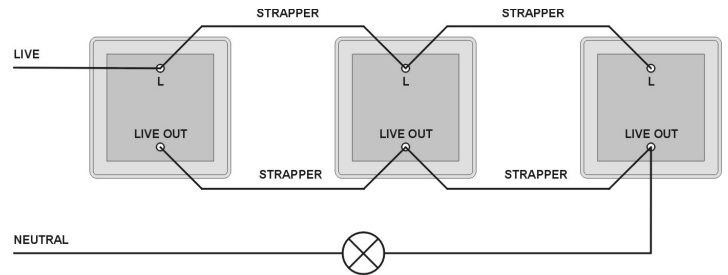

WIRING DIAGRAM FOR INTERMEDIATE AND TWO WAY SWITCHING USING TIME LAG SWITCHES

## Part Numbers

ELLIPSE	Electronic time lag switch push button activated
KH2	Electronic time lag switch touch activated
ELLIPSE/TN	Electronic time lag switch push button activated with neon
KH2N	Electronic time lag switch touch activated with neon

### IMPORTANT NOTICE!

This device should be installed by a qualified electrician in accordance with the latest edition of the IEE wiring regulations.



**C.P. Electronics Ltd**

Brent Crescent

London

NW10 7XR

United Kingdom

Tel: + 44 (0) 333 900 0671

Fax: + 44 (0) 333 900 0674

www.cpelectronics.co.uk

enquiry@cpelectronics.co.uk