

TITAN Metal Consumer Unit Datasheet

Main Switch Units



CONSTRUCTION AND FEATURES:

- Steel construction
- Powder coated durable off white finish
- IP3X
- Multiple knockouts all around the unit (including rear face)
- Label and instruction sheet included
- Accessory pack
- BS7671 Amendment 3 - regulation 421.1.201 compliant
- Raised DIN rail, with tails clamp fitment holes
- Integrated spirit level
- Captive lid screws

TECHNICAL DATA:

- Size options: 10, 14, 18 ways
- Included components:
 - 1 x IS2100
- Compatible with:
 - ROSN, ROM RCBOs
 - MD, MC, MH MCBs
 - RC2 RCDs
 - Various SPDs
- Rated current: 100A
- 1 x Earthing: terminal bar (continuity to enclosure)
- 1 x Neutral terminal bar
- Busbar: 100A pin type
- Neutral cable: Insulated, copper braid, heat pressed ends
- Conforms to: BS EN 61439-3

DIMENSIONAL INFORMATION:

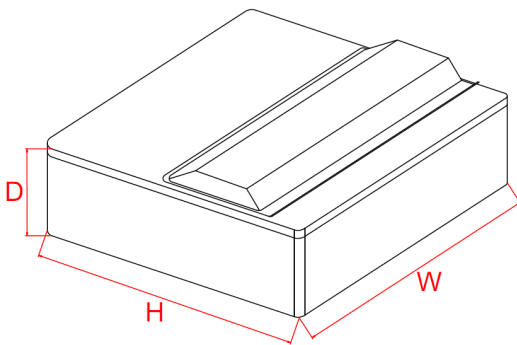

Part No	No of spare ways	H (mm)	W (mm)	D (mm)
TITAN-2/M	2	240	130	114
TITAN-4/M	4	240	160	114
TITAN-6/M	6	240	232	114
TITAN-8/M	8	240	232	114
TITAN-12/M	12	240	304	114
TITAN-16/M	16	240	376	114
TITAN-20/M	20	240	448	114