



## Technical Documents

**1: Drawings DRF100GB & 100GB-A**

**2: Flashings Technical Specifications**

**3: SDS for DRF 100GB & 100GB-A**

*Follow  
Us On*



DEKS

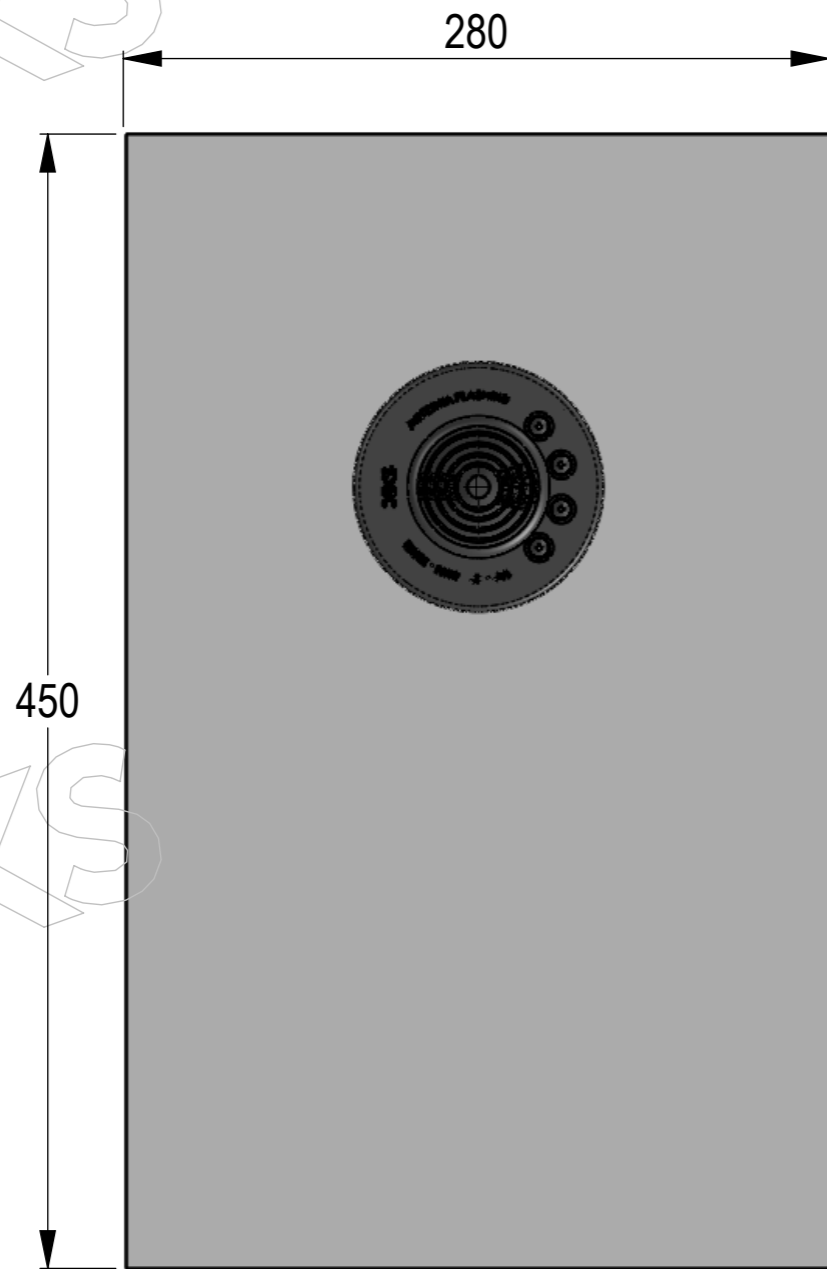

DEKS

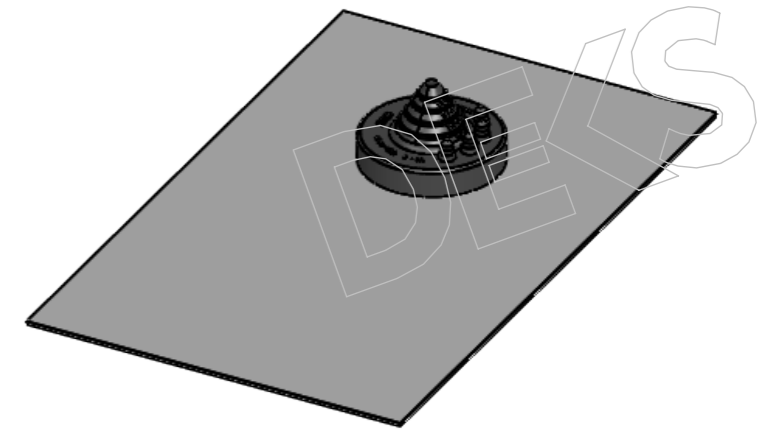

DEKS

DEKS

DEKS

DEKS

PART NO	DISPLAY NAME
DRF100GB	Rapidflash Blk EPDM Gry FF (6-50mm) 280x450mm
DRF100GB-A	Rapidflash Antenna/Solar Blk EPDM Gry FF (6-50mm) 280x450mm

DEKS



## SAFETY DATA SHEET

### Section 1. Identification

**Product Identifier:** Fast Flash, Rapid Flash and Rapid Flash Repair

**Other means of identification:** Proper Shipping name: Not applicable  
Product codes: FFR5-280(AG, B, BR, G, RE), FFR5-370(AG, B, BR, G, RE), FFR5-560(AG, B, BR, G, RE), DRF100GB, DRF100GB-A, DRF101GB, DRF102GB, DRF103GB, DRF104GB-SQ, DRF108GB, RFRBL140, RFRGR140 and RFRTE140.

#### **Recommended use of the chemical and restrictions on use:**

Waterproofing medium for civil constructions

#### **Details of manufacturer or importer:**

Deks Industries Pty Ltd  
2 Logis Blvd,  
Dandenong South, VIC 3175, Australia

#### **Emergency Telephone number**

During business hours: +61 3 87278800  
After hours: Please contact the POISON CENTER (131 126) or a doctor/physician

### Section 2: Hazards Identification

Not classified as Dangerous Goods by the criteria of the Australian Dangerous Goods Code (ADG Code) for transport by Road and Rail; NON-DANGEROUS GOODS.

Based on available information, not classified as hazardous according to Safe Work Australia; NON-HAZARDOUS CHEMICAL.

#### **Other Hazards:**

No information available

**Poisons Schedule (SUSMP):** None allocated.

**Signal Word:** Not applicable

**Hazard Statements:** Not applicable

**Precautionary statements:** Not applicable

#### **General:**

P101 If medical advice is needed, have product container or label at hand.  
P102 Keep out of reach of Children.  
P103 Read label before use.

**Prevention:** Not applicable

**Response:** Not applicable

#### **Storage:**

Store in a well-ventilated place. Keep package tightly closed.

#### **Other hazards:**

None

**Hazard Symbols:** Not applicable

### Section 3. Composition and information on ingredients

#### *Fast Flash & Rapid Flash*

Chemical Identity	Synonym	CAS Number	Proportions (%w/w)
MS Polymer	(Modified silicone)	-	20-50%
Butyl rubber	-	-	20-50%
Non-Hazardous fillers	-	-	10-50%
Aluminium base sheeting	-	-	To 100%

#### *Rapid Flash Repair*

Chemical Identity	Synonym	CAS Number	Proportions (%w/w)
EDPM	(Modified silicone)	-	20-50%
Non-Hazardous fillers	-	-	10-50%
Aluminium base sheeting	-	-	To 100%

### Section 4. First aid measures

For advice, contact a Poisons Information Centre (e.g. phone Australia 131 126; New Zealand 0800 764 766) or a doctor.

Have the product label or SDS with you when calling or going for treatment.

**Ingestion:** If swallowed, do NOT induce vomiting; rinse mouth thoroughly with water and contact Poisons Information Centre. or if swallowed, never give anything by mouth to an unconscious person. Rinse mouth with water. If large quantities of this material are swallowed, call a physician immediately.

**Eye Contact:** Rinse immediately with plenty of water, also under the eyelids, for at least 15 minutes. Remove contact lenses. Get medical attention if irritation occurs.

**Skin Contact:** Wash with plenty of soap and water. If irritation occurs seek medical attention.

**Inhalation:** No hazard expected under normal use. Remove to fresh air if symptoms occur. Seek medical attention if symptoms persist.

**Symptoms caused by exposure:** No data available.

**Medical attention and special treatment:** No further information available.

### Section 5. Firefighting measures

#### **Suitable extinguishing equipment:**

For fires in area use appropriate media, i.e. dry chemical, carbon dioxide, water fog, foam.

#### **Specific Hazards arising from the chemical:**

No special instruction available.

#### **Special protective equipment and precautions for firefighters:**

The material is stable under normal conditions. On decomposition gives off carbon monoxide and other complex fumes derived from organic accelerators, antioxidants, paraffinic oil and processing aids. Use fire-fighting methods appropriated for surrounding materials

#### **Hazchem Code:**

Not applicable

## Section 6. Accidental release measures

### **Personal precautions, protective equipment and emergency procedures:**

Follow personal protective equipment recommendations found in Section 8.

### **Environmental precautions:**

Avoid direct discharge to sewers and surface waters in large amounts. Notify authorities if entry occurs.

### **Methods and materials for containment and cleaning up:**

Sweep up material with normal cleaning equipment and avoid discharge to local drains and sewer systems. Place in normal waste disposal bags for disposal, as per local council statutory requirements.

## Section 7. Handling and storage

### **Precautions for safe handling:**

Avoid eye contact. Do not swallow. Do not eat, drink or smoke in work area. Avoid breathing any dust generated when cutting or processing the material.

### **Conditions for safe storage, including any incompatibilities:**

Store in closed original container. No specific storage precaution required.  
No known incompatibility with normal range of industrial materials.

## Section 8. Exposure controls and personal protection

For this product, no exposure standard assigned for this specific material by Safe Work Australia.

### **Acute oral toxicity**

No data available

### **Acute inhalation toxicity absorption**

No data available

### **Acute dermal toxicity**

No data available

*Note: As published by Safe Work Australia Workplace Exposure Standards for Airborne Contaminants. TWA - The time-weighted average airborne concentration of a substance when calculated over an eight-hour working day, for a five-day working week.*

*These Workplace Exposure Standards are guides to be used in the control of occupational health hazards. All atmospheric contamination should be kept to as low a level as is workable. These workplace exposure standards should not be used as clear defining points between safe and dangerous concentrations of chemicals. They are not a measure of relative toxicity.*

### **Engineering controls:**

None expected to be needed under normal use. Use local exhaust ventilation if in confined spaces. Avoid creating dust.

### **Individual protection measures, for example personal protective equipment (PPE):**

Eye and face protection: None needed under normal use. Safety glasses or goggles recommended if eye contact is eminent.

Skin protection: Material is not considered a skin contact hazard, however wearing suitable protective gloves is recommended

Respiratory protection: None required under normal use.

Thermal hazards: Material is stable and safe to use under normal ambient conditions

Other information: Wash hands with soap and water before mealtimes and at the end of a work period.

Reference standards for (PPE).

Respiratory protection: AS/NZS 1715 and AS/NZS 1716.

Gloves: AS/NZS 2161.1.

Eye protection: AS/NZS 1336 and AS/NZS 1337

## Section 9. Physical and chemical properties

**Appearance:** One piece flexible polymer moulded to a flexible aluminium base – Grey or Black

**Odour:** None.

**Odour threshold:** No data available.

**pH:** No data available.

**Melting point/freezing point:** No data available.

**Boiling point and boiling range:** Not applicable, solid material.

**Flash point:** Not flammable.

**Evaporation rate:** Not applicable, solid material

**Flammability (solid, gas):** Not applicable, solid material

**Upper/lower flammability or explosive limits:** Not flammable.

**Vapour pressure:** Not applicable, solid material

**Vapour density:** Not applicable, solid material

**Relative density:** 0.95 -0.98 g/cm<sup>3</sup> @20 °C (Water=1).

**Solubility:** Insoluble, will not mix in water.

**Partition coefficient: n-octanol/water:** No data available.

**Auto-ignition temperature:** No data available.

**Decomposition temperature:** No data available.

**Viscosity:** Not applicable, solid material

### *Other physical/chemical parameters*

**Specific heat value:** No data available.

**Saturated vapour concentration:** No data available.

**Release of invisible flammable vapours and gases:** Not flammable

**Particle size (average and range):** Not applicable, solid material.

**Size distribution:** No data available.

**Shape and aspect ratio:** No data available.

**Crystallinity:** No data available.

**Dustiness:** No data available.

**Surface area:** No data available.

**Degree of aggregation or agglomeration, and dispersibility:** No data available.

**Redox potential:** No data available.

**Biodurability or biopersistence:** No data available.

**Surface coating or chemistry:** No data available.

## Section 10. Stability and reactivity

**Reactivity:** Stable under normal conditions.

**Chemical stability:** Chemically stable under normal conditions.

**Possibility of hazardous reactions:** None known.

**Conditions to avoid:** No data available.

**Incompatible materials:** Avoid contact with other chemicals.

**Hazardous decomposition products:** No data available.

#### **Section 11. Toxicological information**

No adverse health effects expected if the product is handled in accordance with this Safety Data Sheet and the product label. Symptoms or effects that may arise if the product is mishandled and overexposure occurs are:

**Ingestion:** No adverse effects expected; however, large amounts may cause nausea and vomiting.

**Eye contact:** Exposure to the dust particles when this material is cut, may cause discomfort and physical irritation to the eyes.

**Skin contact:** No adverse effect if handle properly

**Inhalation:** Not applicable as this is a solid material.

**Acute toxicity:** No LD50 data available for this product material.

**Respiratory or skin sensitisation:** Repeated skin contact, and inhalation may result in sensitisation in some individuals. May cause allergic reaction, dermatitis or asthma-like symptoms. Follow good working practice. Avoid ingestion, inhalation, eye and skin contact. Wash hands with soap and water before eating, drinking.

**Chronic effects:** None identified.

**Aspiration hazard:** No data available.

Other information

No data available

#### **Section 12. Ecological Information**

**Ecotoxicity:** No adverse ecological effects are expected.

**Persistence/degradability:** No data available.

**Bioaccumulative potential:** No data available.

**Mobility in soil:** No data available.

**Other adverse effects:** No information available (environmental fate, ozone depletion, photochemical ozone creation potential, endocrine-disruption potential and global warming potential.)

#### **Section 13. Disposal consideration**

Persons conducting disposal, recycling or reclamation activities should ensure that appropriate personal protection equipment is used, see "Section 8. Exposure Controls and Personal Protection" of this SDS.

If possible, material and its container should be recycled. If material or container cannot be recycled, dispose in accordance with local, regional national and international Regulations.

#### **Section 14. Transport Information**

##### ROAD AND RAIL TRANSPORT

Not classified as Dangerous Goods by the criteria of the "Australian Code for the Transport of Dangerous Goods by Road & Rail. (ADG Code).

##### MARINE TRANSPORT

Not classified as Dangerous Goods by the criteria of the International Maritime Dangerous Goods Code (IMDG Code) for transport by sea. This material under the IMDG Code is Not classified as a Marine Pollutant (P).

##### AIR TRANSPORT

Not classified as Dangerous Goods by the criteria of the International Air Transport Association (IATA) Dangerous Goods Regulations for transport by air.

## Section 15. Regulatory information

**This material is not subject to the following international agreements:**

- Montreal Protocol (Ozone depleting substances)
- The Stockholm Convention (Persistent Organic Pollutants)
- The Rotterdam Convention (Prior Informed Consent)
- Basel Convention (Hazardous Waste)
- International Convention for the Prevention of Pollution from Ships (MARPOL).

**This material/constituent(s) is covered by the following requirements:**

- the Standard for the Uniform Scheduling of Medicines and Poisons (SUSMP) established under the Therapeutic Goods Act 1989 (Cwlth) (as amended).
- All components of this product are listed on or exempt from the Australian Inventory of Chemical Substances (AICS).

## Section 16. Other Information

Date of preparation: 23/08/2024

Reason for issue: New issue

Prepared by ChemVit Consulting Pty Ltd

### Source of data

This SDS has been prepared in accordance the Safe Work Australia Preparation of safety data sheets for hazardous chemicals Code of Practice prepared under the Work Health and Safety Act and Work Health and Safety Regulations.

Code of Practice: Labelling of workplace hazardous chemicals

Standard for the Uniform Scheduling of Medicines and Poisons

### Hazard Classification

Australian Inventory of Chemical Substances (AICS) (NICNAS)

Chemical Assessment Reports (NICNAS)

Workplace Exposure Standards for Airborne Contaminants

Globally Harmonized System of Classification and Labelling of Chemicals (GHS)

(United Nations) Global Portal to Information on Chemical Substances (OECD).

*OECD means the Organisation for Economic Cooperation and Development.*

Hazardous Chemical Information System

European Chemicals Agency (ECHA)

*Other references*

National Road Transport Commission, Australian Code for the Transport of Dangerous Goods by Road and Rail, Edition 7.8, 2022.

Lewis, Richard J. Sr. 'Hawley's Condensed Chemical Dictionary 13th. Ed.', Rev., John Wiley and Sons, Inc., NY, 1997.

Australian and New Zealand Emergency Response Guidebook 2021

### Key abbreviations or acronyms used

<p>&lt; Less Than. &gt; Greater Than. AICS Australian Inventory of Chemical Substances. atm Atmosphere. CAS Chemical Abstracts Service (Registry Number). cm<sup>2</sup> Square Centimetres. deg C (°C) Degrees Celsius. g Grams g/cm<sup>3</sup> Grams per Cubic Centimetre. g/l Grams per Litre. IDLH Immediately Dangerous to Life and Health. LC50 LC stands for lethal concentration. LC50 is the concentration of a material in air which causes the death of 50% (one half) of a group of test animals. The material is inhaled over a set period, usually 1 or 4 hours.</p>	<p>LD50 LD stands for Lethal Dose. LD50 is the amount of a material, given all at once, which causes the death of 50% (one half) of a group of test animals. NIOSH National Institute for Occupational Safety and Health. NOHSC National Occupational Health and Safety Commission. OECD Organisation for Economic Co-operation and Development. ppb Parts per Billion. ppm Parts per Million. psi Pounds per Square Inch. STEL Short Term Exposure Limit. TLV Threshold Limit Value. TWA Time Weighted Average. UN United Nations.</p>
---	---

### **Disclaimer**

This Safety Data Sheet was prepared in good faith from the best information available at that time of issue and is based on the present state of our knowledge and to this extent we believe it is accurate. However, no guarantee of accuracy is made or implied and since conditions of use are beyond our control, all information relevant to usage is offered without warranty. Deks Industries Pty Ltd and its Affiliates or Agents shall not be held liable or responsible for any damage or unauthorised use of this information or from contact with this product.

In all cases please ensure you have the current version. The user is cautioned to make their own determinations as to the suitability of the information provided to the circumstances in which the product is used

**END OF SDS**