

DX Flat Roof Fan Kit 50Hz/60Hz

Ducted to Ceiling & Direct Ventilation) for flat roofs

Installation and Maintenance

1.0 Safety Information

IMPORTANT: Installation or replacement of units or spare parts must be carried out by a qualified or Domus approved service engineer/ electrician and in accordance with IEE or local national wiring regulations.

2.0 Introduction

The Domus flat roof Fan Kit is available in 6, 9 and 12 inch impeller sizes suitable for supply or extract and can form the heart of an automatic ventilation system.

Ensure adequate air replacement for the fan and any fuel burning appliance in the room.

Two types of roof fan kits are available, one for a flat roof and the other to cover a pitched roof installation.

The applications are ideally suitable for direct ventilation of a top storey area.

The fan is IP24 splash proof approved with the motor rated at IP44. Roof Terminal components are made in soft grey colours from ultra violet stable Styrosun so they will blend with most decors and will not fade in sunlight.

Roof Installation Accessories

A range of roof installation accessories is available. Further information on page 8.

2.1.1 Coding For Flat Roof Fan Kits

Description	Code
6" Flat Roof Fan Kit Complete	DX6FR
9" Flat Roof Fan Kit Complete	DX9FR
12" Flat Roof Fan Kit Complete	DX12FR

Roof Fan Kits are supplied as a complete package with all installation parts included.

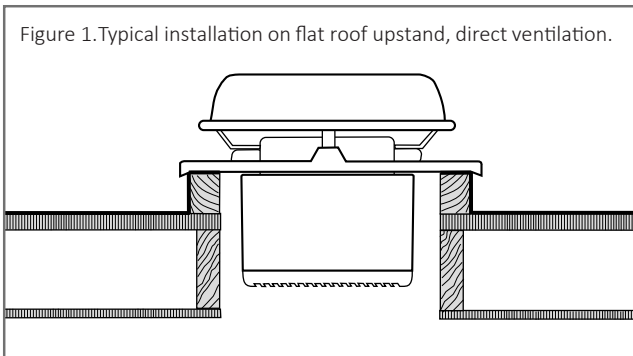

2.1 Sensors

Operated via a separately wired fused spur (by others) or operated via the optional DX-CON remote controller allowing supply or extract, variable speed and automatic or manual switching of several fans if desired (see wiring details).

2.2 Switching

Sensors are available as remote units or integral 'plug in' units. They are able to control multiple fans, depending on sensor and fan types. Integral sensors are quick and easy to install and are aesthetically pleasing, whilst remote sensors give the benefit of location close to the pollutant source.

Remote Sensors should be positioned at least 1.5m above the floor and away from direct sources of heat such as radiators etc.

Remote options include DX-CON and DX-RH (Relative Humidity).

Integral options include DX-PIR, DX-T (run-on timer) and DX-H (humidity).

Further information is available in the relevant section .

Installation and Maintenance

DX Flat Roof Fan Kit 50Hz/60Hz



3.0 General Dimensions

DX Unit	A	B	C*	D
6"	269	161	150	170
9"	337	158	150	180
12"	413	172	150	185

*minimum height of Flat roof upstand (by others).

4.0 Flat Roof Kit Installation

Prepare a timber or builders work upstand on the roof to the dimensions below. Carry roof felt or weathering material over the curb to ensure a good seal. The kit is supplied with the fan, spacer and grille assembled for transit purposes.

The instructions opposite assume the fan assembly has been separated to begin the installation.

Fan Code	A	B	C	D
DX6FR	610	610	300	300
DX9FR	610	610	450	450
DX12FR	695	695	450	450

Figure 2. Flat roof upstand construction details.

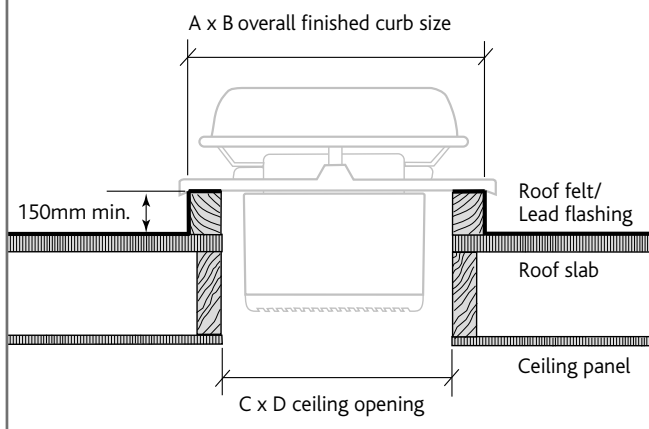
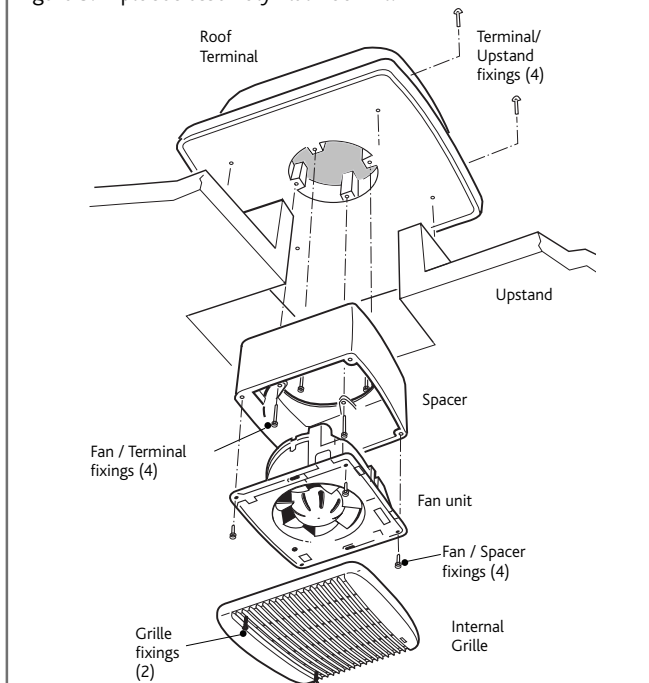

Figure 3. Exploded assembly Flat Roof Kit.



- 1**

Drill through the dimples in the Roof Terminal.
- 2**

Position centrally & squarely over curb and fix using 6mm wood screws and sealing washers.
- 3**

Feed the supply cable through the spacer.
- 4**

Offer up the spacer section to the terminal underside and fix using the 4, 5mm screws provided.
- 5**

Release the electrical cover from the fan plate.

For various wiring options see wiring details page 4.
- 6**

Assemble the fan to the spacer section 4 panhead screws.
- 7**

Fit the grille to the fan, locating top lip before fixing.

Installation and Maintenance

DX Flat Roof Fan Kit 50Hz/60Hz

5.0 Electrical Installation

Electrical work should be undertaken by a qualified electrician in accordance with the wiring regulations.

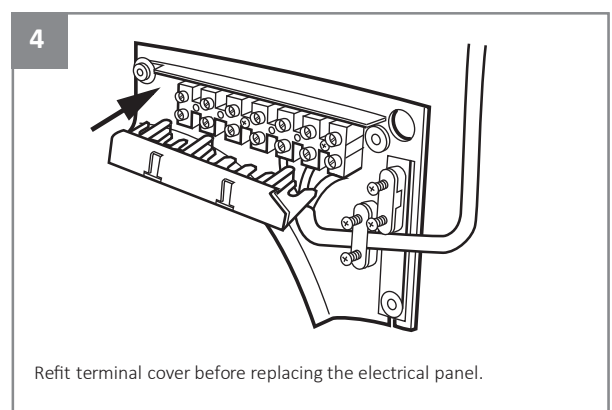
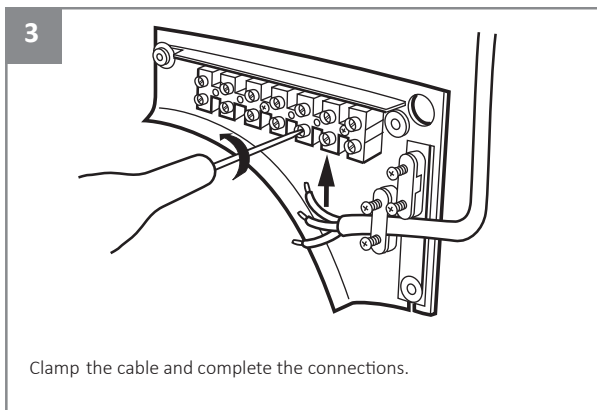
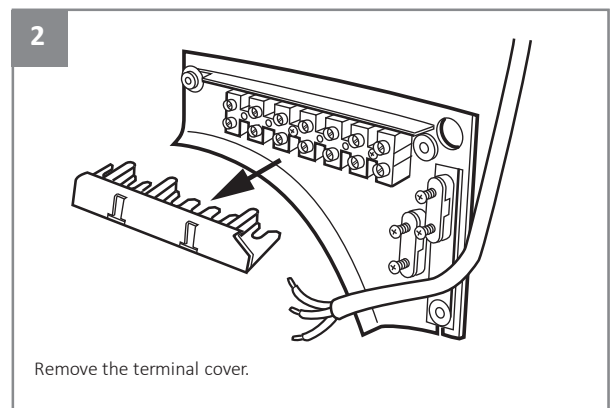
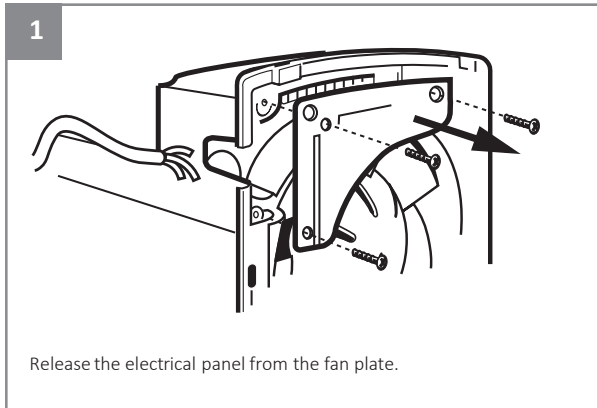

5.1 Wiring

6.1.1 Fan Operated By On / Off Switch

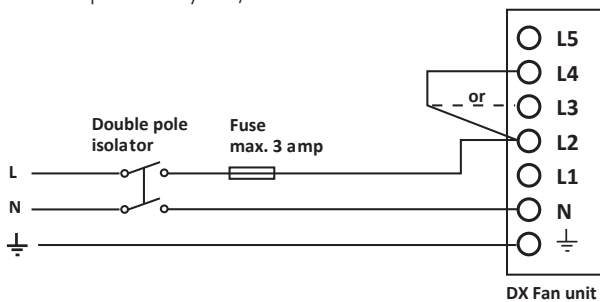

Connect link wire between L2 & L4 for extract OR connect link wire between L2 & L3 for supply.

5.1.2 Fan Operated By Integral Sensor

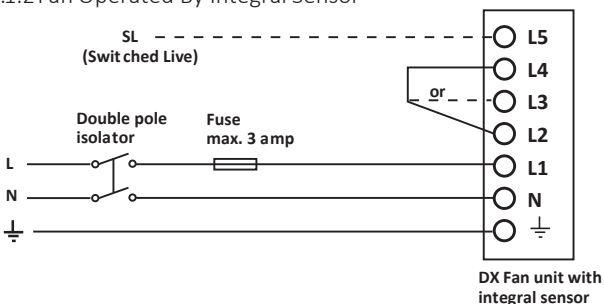

Connect link wire between L2 & L4 for extract OR connect link wire between L2 & L3 for supply. Connect switched live signal to L5 for integral timer module.

5.1.3 Basic Fan Operated By Remote Sensor

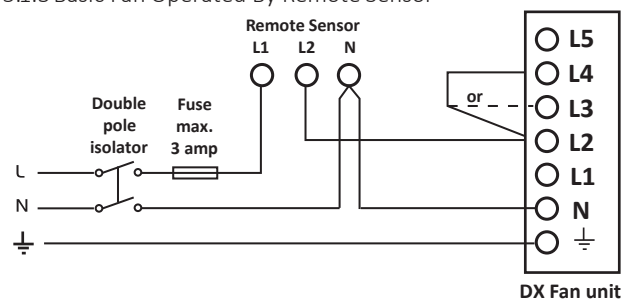

Connect link wire between L2 & L4 for extract OR connect link wire between L2 & L3 for supply.

IMPORTANT

Isolation - Before commencing work, make sure that the unit is electrically isolated from the mains supply.

IMPORTANT

(Shutter Operation DX fans)
There will be a short delay on startup and shutdown of approximately 40 seconds. This is normal.

Installation and Maintenance

DX Flat Roof Fan Kit 50Hz/60Hz



5.1.4 Supply / Extract Fan Operated via remote DX-CON Control

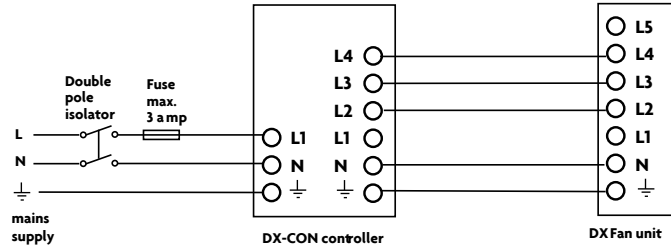

Remote switch may be set: On/Off, Forward/Reverse, Economy/Std. (variable speed), Auto/Manual.

5.1.5 Supply / Extract Fan Operated via remote DX-CON Control and Remote Sensor(s)

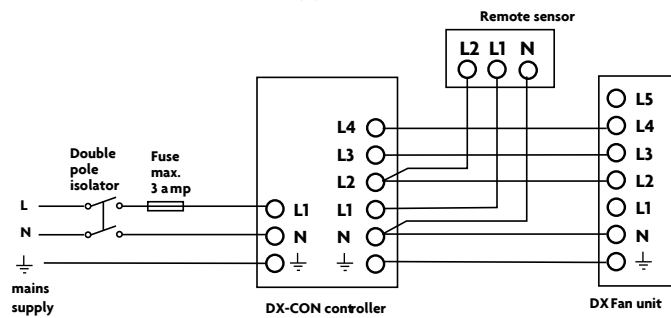

Remote switch may be set: On/Off, Supply/ Extract, Economy/Std. (variable speed), Auto/Manual.

One or more Remote Sensors may be wired in parallel to one DX-CON Control.

Humidity Sensor: DX-RH

5.1.6 Supply / Extract Fan Operated via remote DX-CON Control and an Integral Sensor

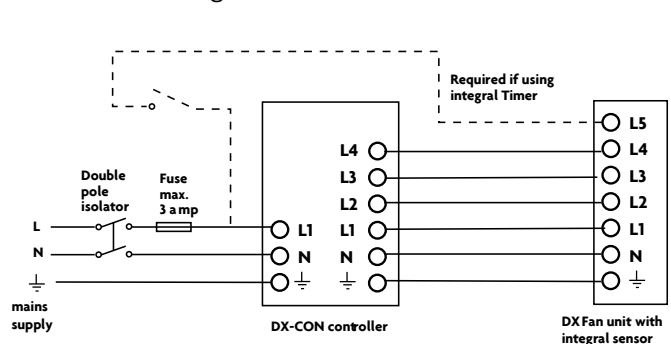

Remote switch may be set: On/Off, Forward/Reverse, Economy/Std. (variable speed), Auto/Manual.

Maximum one Integral Sensor per fan, 6/9/12 denotes unit size identity. Humidity Sensor: DX-H6/9/12

Passive Infra Red Sensor: DX-PIR6/9/12
Run on Timer: DX-T6/9/12.

A single sensor will switch all fans if more than one fan is being operated by a single DX-CON controller.

NOTE: Multi-fan options:

Up to 5 fans (size 6"/9") can be controlled by one DX-CON.

Up to 2 fans (size 12") can be controlled by one DX-CON.

Do not mix different fan sizes on the same controller.

A single sensor will switch all fans if more than one fan is being operated by a single DX-CON controller.

NOTE: Multi-fan options:

Up to 5 fans (size 6"/9") can be controlled by one DX-CON.

Up to 2 fans (size 12") can be controlled by one DX-CON.

Do not mix different fan sizes on the same controller.

5.2 Unit Consumption & Weight

Model	Input Power (W)		Weight (kg)
	Max.	Economy	
DX6FR supply & extract	38	20	6.3
DX9FR supply & extract	50	37	8.7
DX12FR supply & extract	100	70	11.0

Note figures are for extract only at 50hz.

5.3 Electrical Specification

230V ~ 50Hz / 220V ~ 60Hz Class I. Motor thermally protected by overload device. Cable: 1mm max. or min. Fuse: 3 amp (if fan is supplied from a 5A lighting circuit, no local fuse is required).

Note: If 2 x 12 inch fans or 5 x 6 or 9 inch fans are used in the same operating mode in the same room they should all be controlled from the same CON speed control. This avoids the possibility of one fan (if speed controlled at a lower flow rate) being stalled by the other fan(s).

Adequate make-up air provision sufficient to provide ventilation in accordance with building regulations is required in all rooms. This should be checked during commissioning with all fans in the same room running together in all possible configurations.

The automatic shutters, motor bearings should be frequently inspected and maintained to ensure they open fully/operate satisfactorily. Use of an RCD and fused spur with 1A, Bussmann TDC180, BS1362, fuse (Farnell order no: 1123029) for 1 fan or 2A, Bussmann TDC180, BS1362 fuse (Farnell order no: 1123032) for 2 or 3 fans is recommended.

Always confirm airflow direction before commissioning.

Installation and Maintenance

DX Flat Roof Fan Kit 50Hz/60Hz

5.4 Fitting Integral Sensors (Optional)

Note: Before following the pictorial sequence shown, first remove the fans front cover grille (2 screws). Release the four main corner screws and lift out the motor/fan plate assembly. Remove the electrical cover plate opposite the sensor plate. Follow the pictorial sequence on this page.

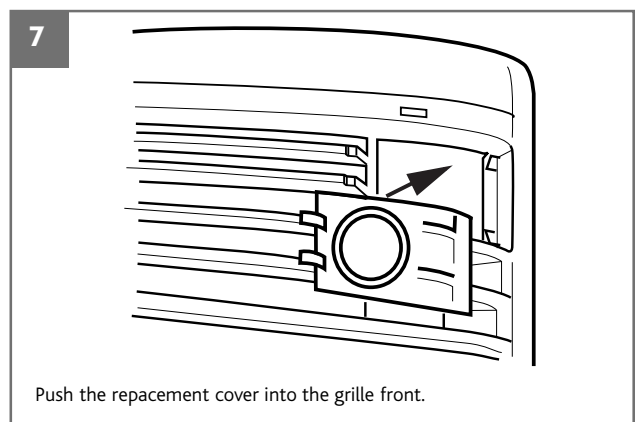
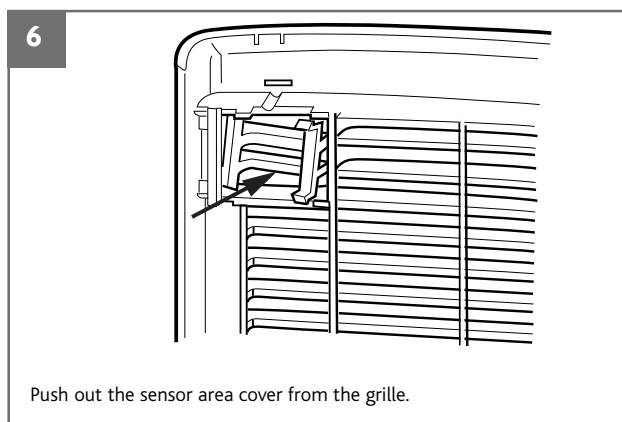
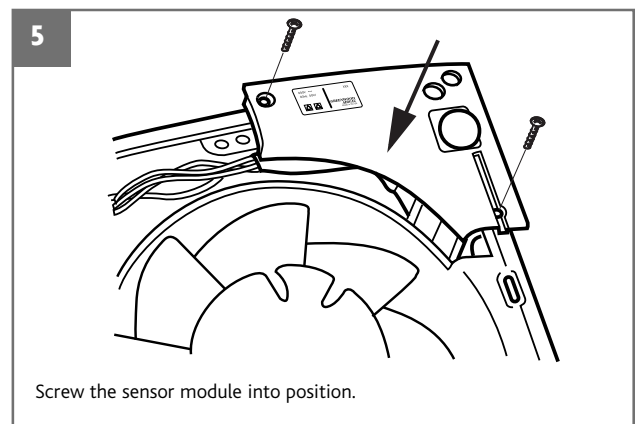
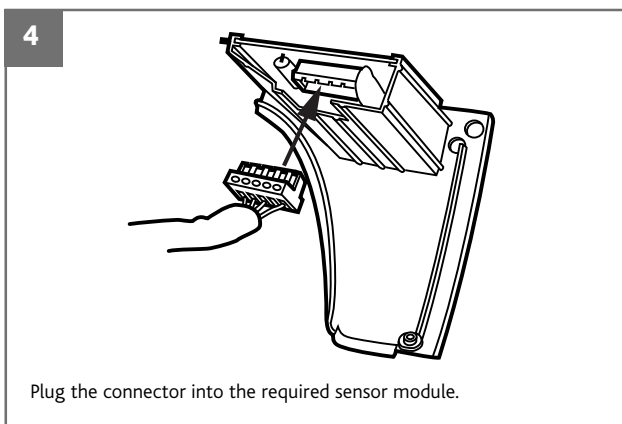
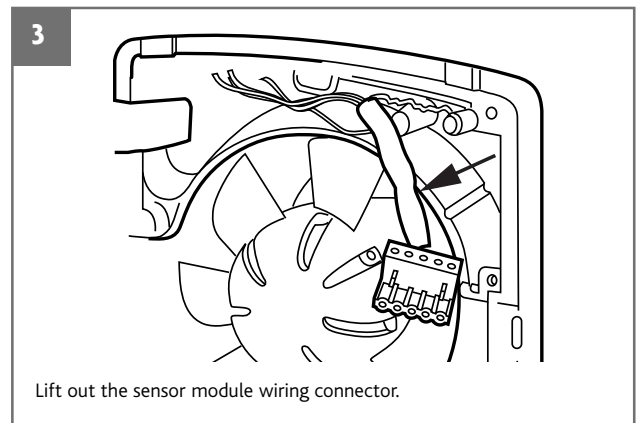
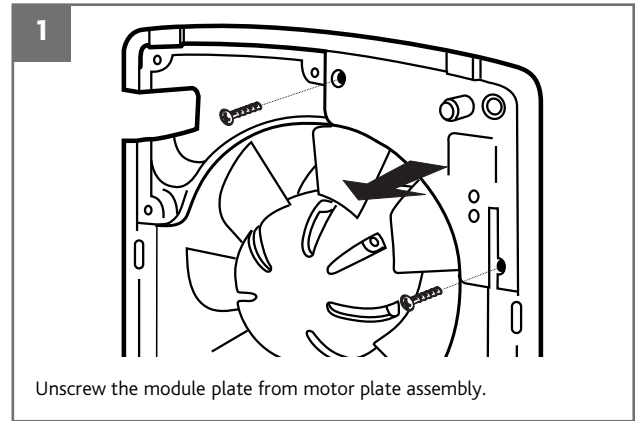

Installation and Maintenance

DX Flat Roof Fan Kit 50Hz/60Hz

5.5 Fitting Remote Controller DX-CON or Remote sensors (optional)

The DX-CON Multi Fan Control provides supply or extract, variable speed and automatic or manual switching of several fans if desired, (see note below). The control is best mounted approx 1.5m above the floor. Remote Sensors are available for Humidity only. Remote Sensors should be positioned at least 1.5m above the floor and away from direct heat sources e.g. radiators.

Note:

Up to 5 fans (size 6 / 9 inch) can be controlled by one DX-CON.

Up to 2 fans (size 12 inch) can be controlled by one DX-CON.

Do not mix different fan sizes on the same controller.

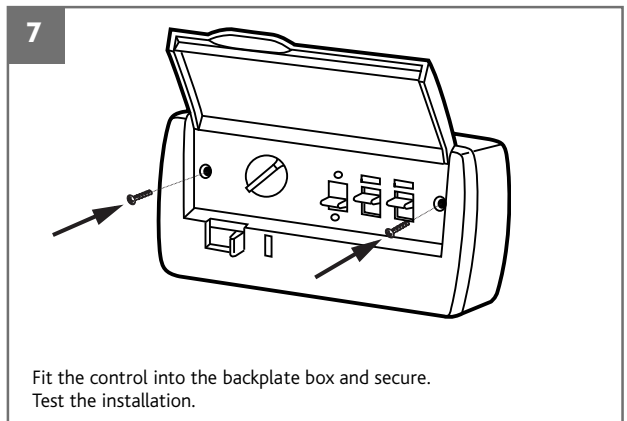
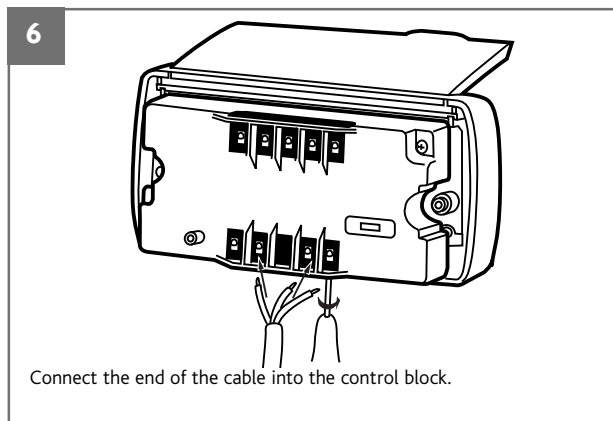
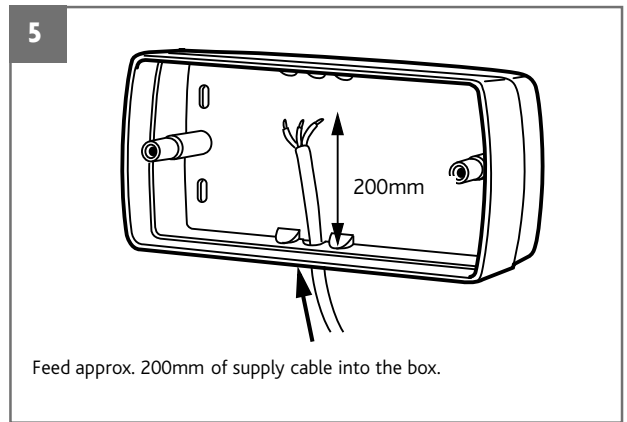
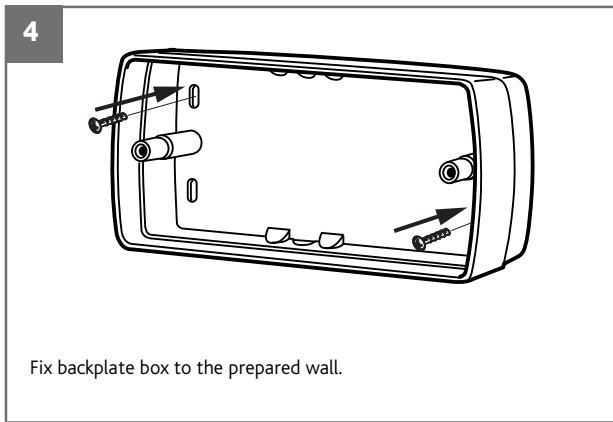
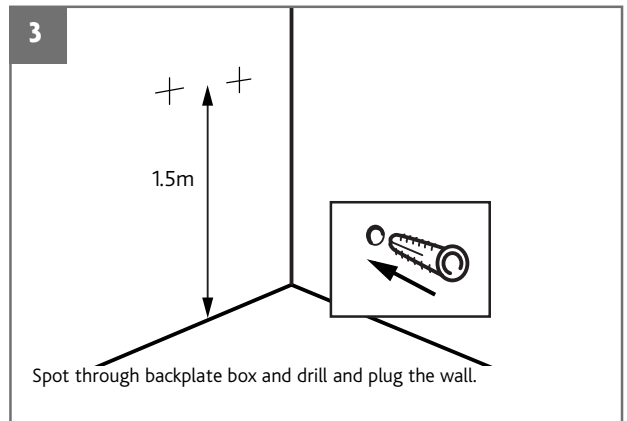
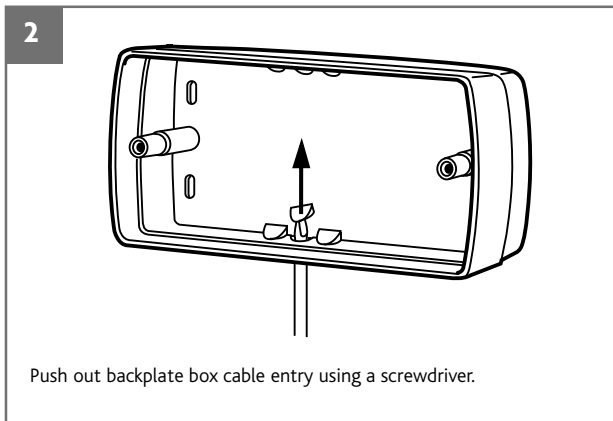
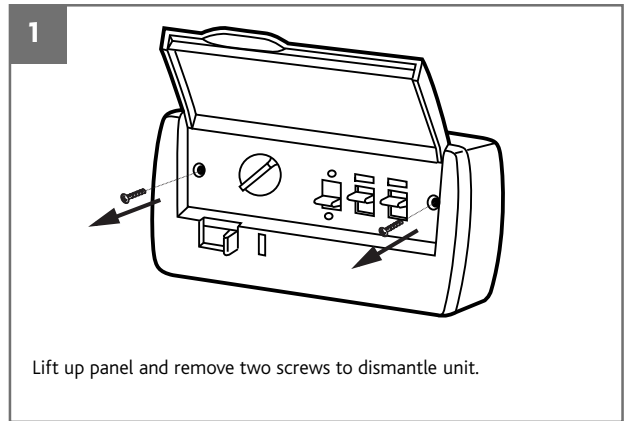

Installation and Maintenance

DX Flat Roof Fan Kit 50Hz/60Hz



6.0 Ancillaries

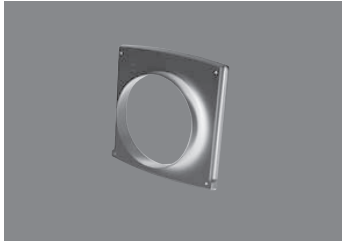

Single Spigot Adaptor

Used in conjunction with flexible ducting systems.

Mounted onto the front of the Spacer section using the 4 off 5mm x 40mm brass screws supplied with the Single Spigot Adaptor. Replaces the internal grille.

Can also be used connected directly to a Roof Terminal using the 4 off 5mm x 40mm brass screws supplied with the Single Spigot Adaptor. Manufactured from HIPS material.

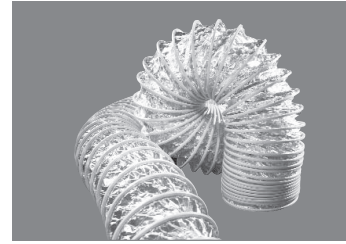

Flexible Ducting and Installation Accessories

A full range of ducting and installation accessories is available from Domus. Call Domus on 02920 885231 to request literature.

7.0 Maintenance

Periodically, at least once a year or more frequently in case of heavy use, remove the dirt and encrustation from the grille(s) fan impeller and motor casing. Ensure the impeller is not cracked or deformed and is able to rotate freely and without oscillation.

Do not use any solvents to clean this product.

8.0 Replacement Of Parts

As a manufacturer Domus is aware that time is important. In the event of a breakdown of this equipment, it should be adequately packaged and returned to Domus.

Please telephone Domus before posting your unit. A returns number will be issued to identify your package.

9.0 Warranty

The 2 year warranty starts from the day of delivery and includes parts and labour for the first year. The remaining period covers replacement parts only.

This warranty is void if the equipment is modified without authorisation, is incorrectly applied, misused, disassembled, or not installed, commissioned and maintained in accordance with the details contained in this manual and general good practice.

Installation or replacement of units or spare parts must be carried out by a qualified or Domus approved service engineer/ electrician and in accordance with IEE or local national wiring regulations.

The product warranty applies to the UK mainland and in accordance with Clause 14 of our Conditions of Sale.

Customers purchasing from outside of the UK should contact Domus International Sales office for further details.

A unit returned to Domus should be suitably protectively packaged and clearly marked with the 'returns number' obtained from Domus prior to posting.

10.0 After Sales Enquiries

For technical assistance or further product information, including spare parts and replacement components, please contact the After Sales Department.

Technical or commercial considerations may, from time to time, make it necessary to alter the design, performance and dimensions of equipment and the right is reserved to make such changes without prior notice.



Domus Ventilation

Block C
Caerphilly Business Park
Van Road
Caerphilly
CF83 3ED

Tel: +44 (0)3443 715523

Fax: +44 (0)3443 715524

Email: vent.technical@domusventilation.co.uk

www.domusventilation.co.uk

LAB1347R May 2018

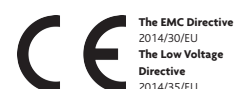

The EMC Directive
2014/30/EU
The Low Voltage
Directive
2014/35/EU