

E-MATIC

PMSC - Occupancy Sensor

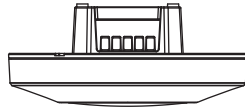

TECHNICAL DATA

Rated voltage: 230V~ 50Hz

Load:

- Load 1(↑) for Lighting
Incandescent: 2200W
High voltage Halogen: 2200W
Low voltage Halogen: 1200VA/1000W
Fluorescent: 1200VA/140uF
Energy saving or LED lamp: 800VA/600W
LED lamp : max. 13W(Philips) x 46pcs
LED driver : max.400W (PF=0.5)

- Load 2(C1, C2) for HVAC (Dry contact N.O.):
Max. 1A for 5-250VAC (cosφ=0.4) or
Max. 5A for 5-250VAC (cosφ=1) or
Max. 5A for 5-30VDC

Ingress Protection:

- IP20 for flush mount with European standard junction box
- IP20 for flush mount with spring clip box
- IP54 for surface mount with surface mount box

Operating Temperature:

-20°C ~ 45°C

PACKAGE CONTENTS

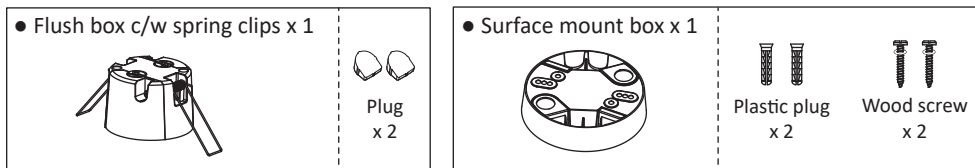
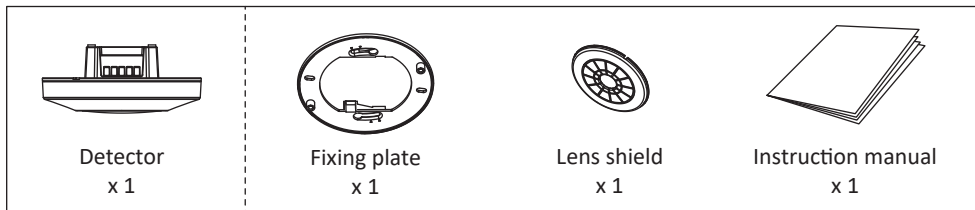

PRODUCT DESCRIPTION

Features

This series is available in various mounting ways, e.g. surface mount and flush mount both applicable, and can fit to a standard 1 gang pattress box. The accessories surface mount box and back cover with spring clips to meet different mounting requirement. A red LED indicator is equipped for Test Function.

Dimension

- Detector

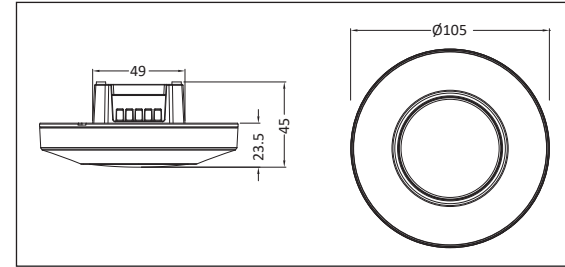

- Detector with surface mount box

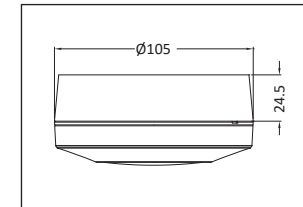

- Detector with flush mount spring clips

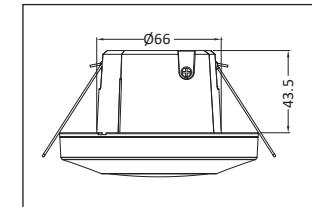

OPERATION AND FUNCTION

Detection Range:
Approx. Ø9m/360° at 2.5m height, 20°C.

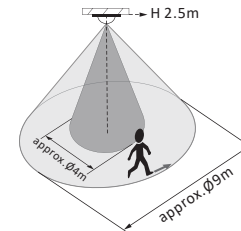

Time Adjustment:

Time 1 (for ↑) with 7 steps adjustable: 1s (Pulse)-30s-1m-5m-15m-30m-Test

Time 2 (terminals C1, C2) with 7 steps adjustable: 10s-1m-5m-10m-20m-30m-60m

Note: The detector LED indicator will blink 3 times when the potentiometer is adjusted and the desired step is successfully selected.

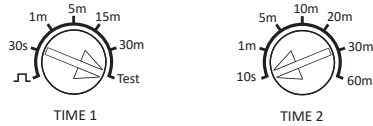

Lux Adjustment:

With 7 steps adjustable (for Load 1 only): 10-100-500-1000-2000 lux-Daylight(☼)-Teach In(☞)

* Load 2 is independent and not controlled by Lux setting.

Note: The detector LED indicator will blink 3 times when the potentiometer is adjusted and the desired step is successfully selected.

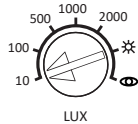

Pulse Function

For staircase timer switch operation (see FIG. 2); for each detection the load will switch on for 1 sec and off for 9 sec as a complete cycle before next detection.

Test Function

Under Test mode the load will switch on for 3 sec for each detection, and switch off for 2 sec before next detection. Under Test mode the Lux setting is deactivated.

Presence Function

During the delay time after the sensor was triggered, the Presence function will force the sensor to switch off the load when the ambient brightness is higher than the Lux setting value for 5 min, regardless of any movement detected.

Teach In Function

Switch the Lux setting to Teach-in mode at the desired ambient brightness level. The load will turn OFF. The sensor LED indicator will flash for 20 sec while sensor learning the ambient brightness. The sensor LED indicator and the load will stay ON for 3 sec and then go OFF, then the learning process is done. The learned brightness value is accepted as the new brightness switching value.

When the ambient lightness is lower than 5 lux, the sensor will accept 5 lux as the brightness switching value. When the ambient brightness is higher than 2000 lux, the sensor will accept 2000 lux as the brightness switching value.

Push-button Function (Optional)

An optional N.O. momentary external push button can be wired to the sensor. Short press the button once to turn on the load, delay time according to TIME setting; short press it again to turn it off, delay time (for OFF) according to TIME setting. Please note when using the push button feature the LUX level is disregarded.

INSTALLATION AND WIRING



- Please disconnect power completely and read the entire instruction manual carefully before installation and retain for future reference.
- Installation and assembly of electrical equipment must be carried out by qualified electricians. Contact a qualified electrician in the event of fault or break down.
- A circuit breaker (250VAC, 10A) type C according to EN60898-1 of load 1 (↑) must be installed in the fixed wiring for protection. A circuit breaker (250VAC, 6A) type C according to EN60898-1 of load 2 (C1,C2) must be installed in the fixed wiring for protection.

Wiring

- Normal wiring connection.

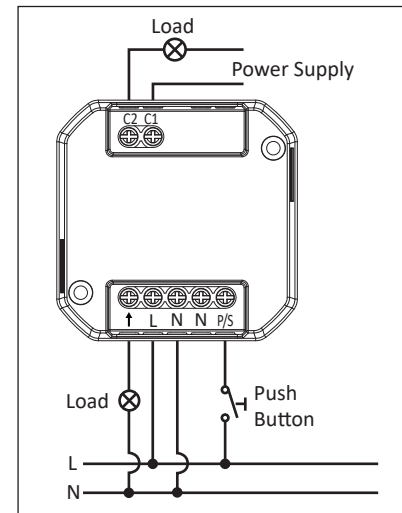

FIG.1

- For staircase timer switch operation.

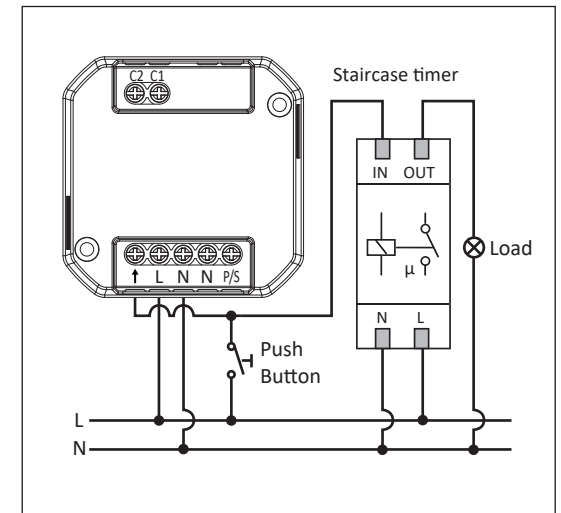

FIG.2

- Multiple sensor wiring in parallel (max. 6 pcs)

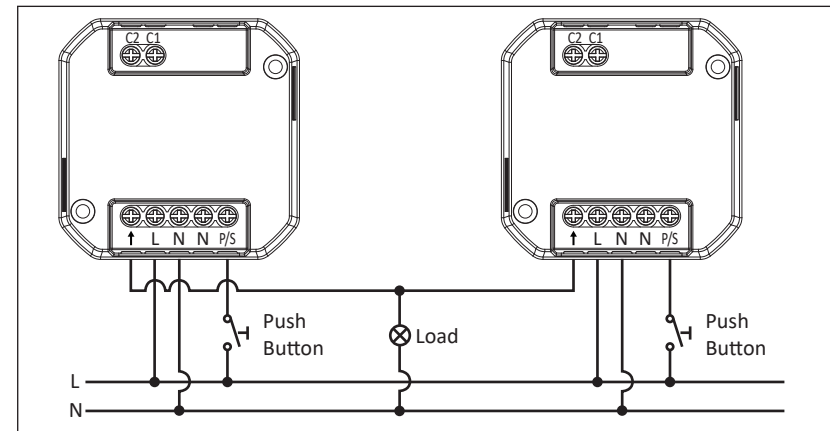

FIG.3

Installation Procedure

• Ceiling flush mount with either a 1 gang or round pattress box (not supplied)

1. Twist to remove the decorative frame.
2. Strip between 6 - 8mm of cable sheathing for wiring. (See FIG.4). Please refer to illustration of FIG.1~3 for correct wiring connections.
3. Please refer to illustration of FIG.5 for correct installation. Fix the fixing plate to the box. After wiring, fix the detector to the fixing plate with 2pcs captive screws. (See FIG.5)
4. Re-attach the decorative frame.
5. Restore the power supply.

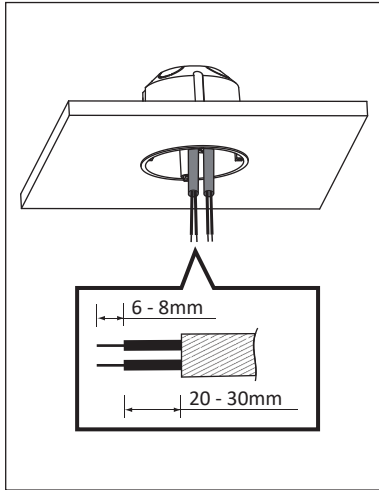

FIG.4

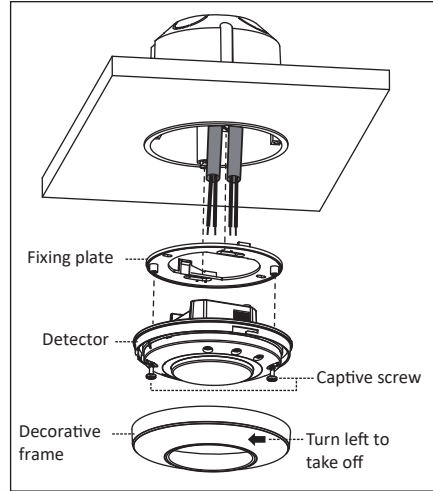

FIG.5

• Ceiling flush mount box c/w spring clips (supplied)

1. To install the detector, please drill a hole with diameter of 68mm. Please strip off 6 - 8mm of cable sheathing for wiring. (See FIG.6)
2. Please refer to illustration of FIG.8 for correct installation, and fix the flush mount spring clips to the detector with 2pcs captive screws. (See FIG.7)
3. Please refer to illustration of FIG.1~3 for correct wiring, and then tighten the flush mount access sides with 2pcs captive screws. (See FIG.7)
4. Raise the two spring clips, and insert the detector into the drilled hole on ceiling. (See FIG.8)
5. Restore the power supply.

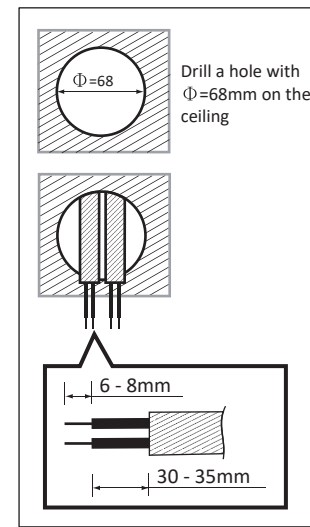

FIG.6

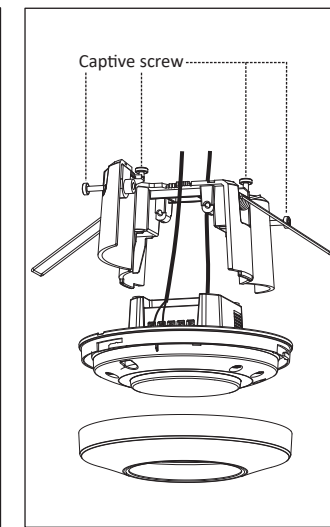

FIG.7

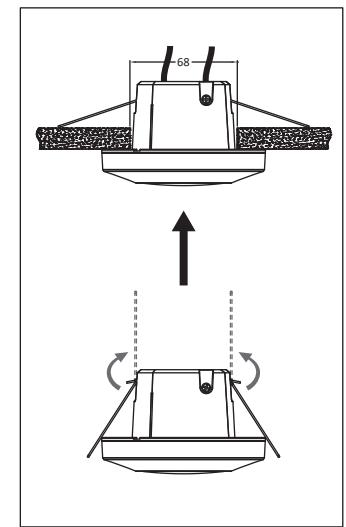

FIG.8

• With surface mount box (supplied)

1. There are 4 pairs of knockouts with various distances from 56mm to 80mm on the bottom cover of combined surface mount box for different mounting applications (See FIG.9). Select two same figures on both ends for the corresponding distance for fixing. (See FIG.10)
2. To feed power cables through the side of surface mount box, please remove the cable entry knockouts on the side of surface mount box, a grommet or seal may required to maintain the IP protection. Then feed the cables through the entry and into the surface mount box. Strip off 6 - 8mm of cable sheathing for wiring. (See FIG.11)
3. Secure the base with appropriate fixings, ensuring the rubber washers are used. (See FIG.12)
4. Refer to wiring diagrams for correct wiring connection (See FIG.1~3) and fix the detector into on to the surface mount box with 2pcs captive screws. (See FIG.13)
5. Re-attach the decorative frame and restore the power supply.

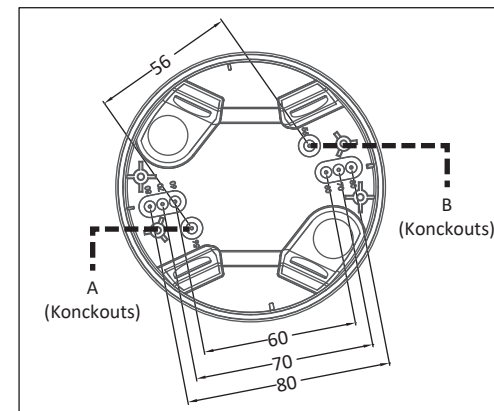

FIG.9

NO.	A	B	The distance between A and B
1	56	56	56mm
2	60	60	60mm
3	70	70	70mm
4	80	80	80mm

FIG.10

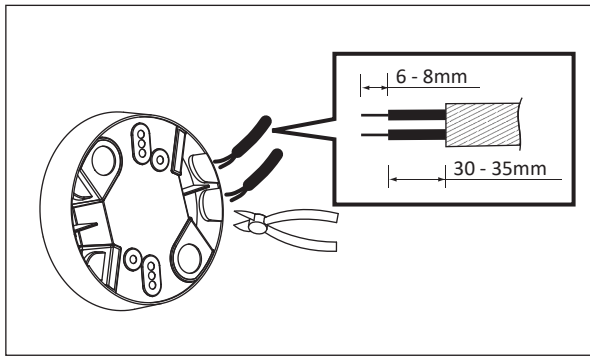

FIG. 11

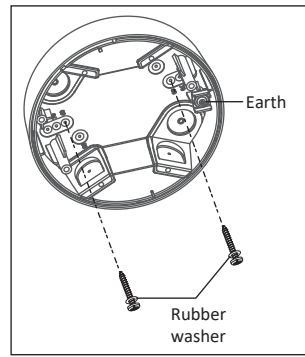

FIG. 12

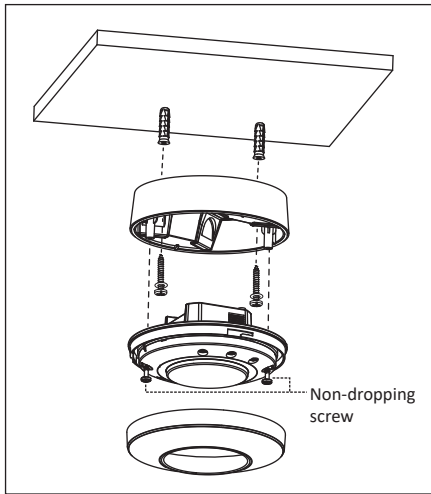

FIG. 13

Walk Test

It takes approximately 60 Seconds for the sensor to warm up after power is switched on. The purpose of a walk test is to check and adjust the detection coverage of the sensor. Set Time VR adjuster to "Test", and then conduct the walk test. Pay attention to the walking direction in the walk test.

The sensor is more sensitive to movement across the detection range and less sensitive to movement directly towards it. The sensor LED indicator and the load will switch ON for 3 sec for each movement detected, and switch OFF for 2 sec before next trigger. Set the Time VR adjuster to the desired setting after walk test. The sensor LED indicator will stay ON during the warm up period.

Lens Shield

Undesired detection areas can be shielded off by fixing the enclosed lens shield onto the lens. Trim the lens shield with scissors either horizontally or vertically until the desired detection area is obtained.

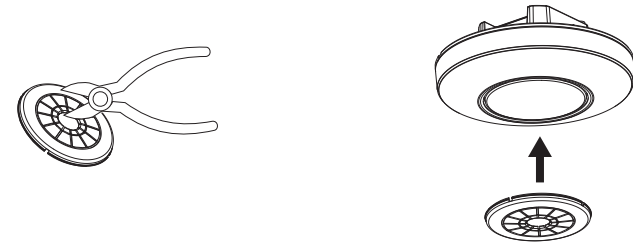

TROUBLE SHOOTING

1. Unit will not function at all/Lights won't turn on

- Check wiring to make sure that you have correct AC power at the unit.
- Check the wiring from the unit to the source of power to make sure you have wired the unit correctly.
- Check the ambient light control to see if it was set at your desired level.

2. Detector clicks but does not work

- Check the lights function correctly independently.

3. Lights go on and off quickly

- Ensure light and heat are not being reflected onto the detector. Check for white or reflective surfaces that may be causing the problem.
- Note the detector is more sensitive in cold weather.
- Make sure the sensor is not installed close to an air conditioner or ventilation outlets.
- Make sure the Time setting is not set to Pulse function.
- Make sure the Lux setting is not set to Test Mode position.

4. Lights stay on

- Light bulb sockets may be wired directly to the power source. Recheck the wiring diagram.
- Adjust time to minimum, and ensure unit is firmly fixed to a solid object free from vibration.
- Ensure detector is not being activated by stray moving heat sources such as heating outlets.

5. Detector false Activation

- Adverse temperature changes can result in unwanted activations.

6. Maintenance and repair

- Do not attempt to repair as there are no serviceable parts inside and could invalidate warranty or result in personal injury.
- Clean detector lens and outside casing with a soft damp cloth.

E-Matic Energy Management Solutions

10 Sandersons Way, Marton,
Blackpool, Lancashire, FY4 4NB

Email: enquiries.ematic@adivision.co.uk

Web site: www.e-matic.co.uk

Environment:

Please do not dispose the packaging as unsorted waste, use the recycling facilities provided by your local authorities. When the sensor comes to the end of its life or you choose to update or upgrade by replacing it, then do not dispose with your normal household waste. Please recycle where facilities exist. When you need to dispose of this fitting, check with your retailer or local authority for suitable options.

Due to our policy of continuous improvement we reserve the right to change specification without prior notice. Errors and omissions excepted. These instructions have been carefully checked prior to publication. However, no responsibility can be accepted by E-Matic for any misinterpretation of these instructions.

