

Smart Wi-Fi Wall Touch Switch 1G/2G/3G (No Neutral Wire Needed)

SKU Code: SHA5336-1G / SHA5337-2G / SHA5338-3G

Wireless Remote Control your switch from anywhere, Works with Alexa & Google Home



Remote Control

You just only need a smart phone to control the light no matter where you are in the world



Features

- No Neutral Wire Needed:** Does not require a neutral wire and can be easily installed without rewiring your existing wiring. Simply replace your old switches to work with our Smart Touch Switches. Our single live wire design without a neutral wire is really an irreplaceable solution for many traditional homes that couldn't use Smart Switches earlier due to Neutral Wire which was mandatory but not any more with our new design Smart Touch Switches
- Touch Control & LED Backlight:** Tempered glass touch screen design, 40ms high-speed touch-sensitive response. Strong/weak blue indicator shows the on/off clearly, easy to find in darkness, but zero-impact on sleep. Low power consumption and long service life.
- Voice Control:** Works with Alexa and Google Home for easy voice control.
- Automations:** Control your switches, set timers create scenes and routines to automate your lights according to your schedule
- Safety Protection:** Fire-retardant material and Aluminum shell for heat dissipation. 4mm thick tempered glass panel is waterproof and safer than push button, prevent electric shock even if touching by wet hands. No color aging, easy to clean and no scratch.

Technical Specifications

Model No	: ETS311W/ETS312W/ETS313W
Gang	: 1/2/3 Gang
Colour	: Black
Operating Voltage	: AC180-240V/50Hz 2A
Rated load	: Each gang less than 300W
Self-consuming power	: Less than 1mA
Operating environment	: -20°C~50°C, less than 95%RH
Wireless frequency	: Wi-Fi 2.4GHz (5G not supported)
Wireless standard	: IEEE802.11b/g/n 2.4GHz
Lifelong	: More than 100,000 times
Dimension	: 86*86*35mm
Weight	: 140g

*No neutral wire needed.

Installation Diagram

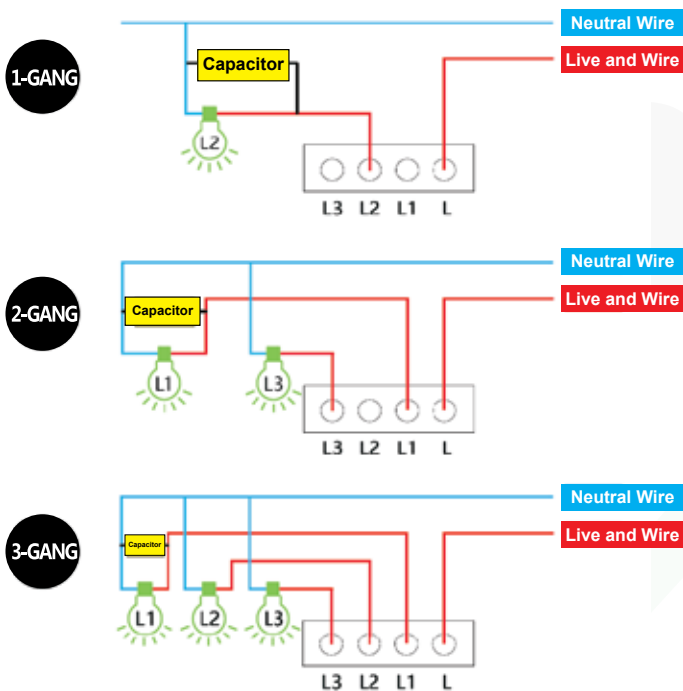

1. Make sure electricity is cut off during the installation.
2. The switch must be installed without electricity, electricity must be turned on after the installation (cover the glass touch panel), touch for test after 10 seconds or the switch will not work well.

How to Pair the product to the APP

1. Install ENERJSMART app into smartphone or tablet device or scan the QR code, download and install into smartphone or tablet device.
2. Download an app called ENERJSMART.
3. Once app is downloaded, open the app and select Register.
4. The app should automatically detect your country code. If not, please select the country code for your country of residence.
5. Enter either your email address or phone number. (If you enter your phone number you will be sent a verification text message which you will need in the next step).
6. If you're setting up using a phone number, please enter the verification code that was sent to your phone and your desired password, then select Confirm.
7. If you're setting up using an email address please enter your desired password, and select Confirm.
8. You have now successfully created an account and you're now ready to start setting up your Smart bulbs and fixtures.
9. Select the Plus (+) in the top right corner to add a device.
10. Select type of Device you want to add.

For reference, we are showing with Wi-Fi Switch
11. Complete the wiring of your Wi-Fi Touch Switches and switch on the power. If the blue indicator light is blinking rapidly, it means the device is already in pairing mode. If not then Reset-hold the touch switch on/off button for 10 seconds till the blue indicator lights flashes rapidly. Please complete the pairing process within 3 minutes from the time the device was powered on.
12. Connect to your desired Wi-Fi network, enter your password, then select Confirm.

13. If a blue box appears at the top of the screen it means you're currently not connected to a Wi-Fi network.
14. Once you select Confirm after entering your password, the app will start to pair the Wi-Fi Switch to your app.
15. If you get a message that says "Failed to Add" it means that the connection has failed. You may have to enter the Wi-Fi Switch into pairing mode again, and repeat steps 8 through 11.
16. Once your Wi-Fi Switch successfully connects to the app, the below screen will pop up and you can change the name of your Wi-Fi Switch/Device.

For Example: 16 Fixture. It's best to make this simple so that if you would like to connect this to your Alexa App or Google Home, it will be easier for the smart assistant to understand which light you would like to control.

After naming your Wi-Fi Switch, select Done.

17. You're now able to control your Wi-Fi Switch in the ENERJSMART app.

How to Pair the product to Alexa



If you're new to Echo, it's a super smart speaker from Amazon that responds to your voice.

Once you've bought Amazon Echo and downloaded the ENERJSMART App, you'll need to enable...

1. **Enable the ENERJSMART App**
In your Alexa app, tap Skills in the menu and search for ENERJSMART. Tap Enable.
2. **Link Account**
Enter your ENERJSMART App username and password and follow the onscreen instruction.
3. **Talk to Alexa**
Now the fun part Ask Alexa to control your ENERJSMART device. Check a full list of things you can control by clicking here.

How to Pair the product to Google Home



Now you can use Google's voice-activated speaker to control your Smart Home Sockets and adaptors. With the Google Assistant, you can turn on lights without pressing a button.

1. **Setup**
Start by getting the Google Home app and setting up your Google Home if you have not done this already.
2. **Add ENERJSMART Action**
In the Google Home app, tap the menu icon and select Home Control. Then tap the + button to see a list of Action tapping ENERJSMART to select the Action.
3. **Link your ENERJSMART Account**
Now follow the in-app instructions to link your ENERJSMART App account. Once complete you'll be able to say "Okey Google, turn my lamp on" or "Okay Google, set hallway to ON/OFF".

SMART WIFI TOUCH SWITCH

Control your home in a smart way



Voice Control

To control your light just speak to it



Thank you for choosing ENER-J!

Customer satisfaction is our TOP priority, please let us know how you felt about your experience. Happy? We are so happy that you are pleased with our product. Feel free to express your newfound joy! Share your experience by writing a review.

Not Happy? If you are not fully satisfied with the item you received, have any problems like damages, or questions, please contact us. We typically respond within 24-48 hours.

Caution

Products should be installed as per the instructions mentioned in this manual and also as per current electrical codes National Electric Code (NEC).

To avoid the risk of fire, electrical shock or injury, it is advisable that the installation is done by a trained Electrician. Also it is important that mains power supply is switched off before the product is installed or repaired.

It is advisable to keep the manual for future reference.

Please Note

Wi-Fi frequency is 2.4GHz and not 5GHz (5GHz not supported). You can do this by contacting your broadband service provider and requesting to either switch to 2.4GHz entirely or split it between 2.4GHz and 5GHz.

If despite following the process as instructed above, you still fail to add the device, then possibly there is a firewall on your Wi-Fi router blocking this device to be connected to your Wi-Fi Router. In such a case you would need to disable the firewall, add this device following above process and once the device is added, enable the firewalls back again.

Stuck? Confused?

Contact our Technical Support team on:

T: +44 (0)2921 252 473

E: support@ener-j.co.uk

Lines are open Mon - Fri (8am to 4pm)