

## FAST TRACK RANGE - TECHNICAL SPECIFICATION

### 90MM STRAIGHT CONNECTOR & AIRTIGHTNESS PARTS

#### Features & Benefits

- For connecting straight pieces of ductwork
- For installation in ceilings and walls
- For circular 90mm Range ductwork
- Easy to mount with seal-ring and click-ring
- Anti-static and anti-bacterial properties
- Part of the certified Fast Track Range system



#### Size

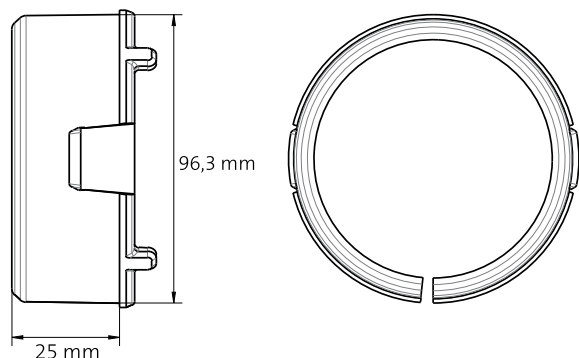
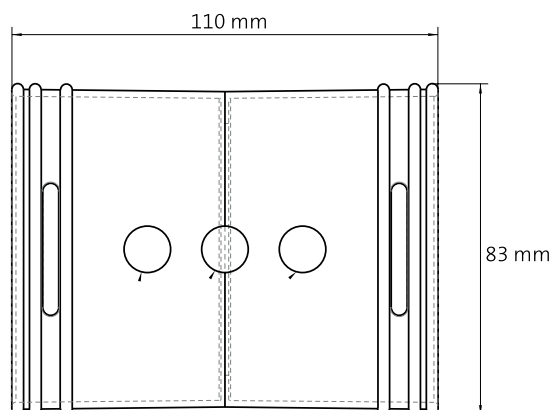

#### Airtight seal + click-ring

The seal-ring and click-ring for the circular ductwork are vital components of the Fast Track Range system and ensure airtight connections. These components are used to make all mechanical connections between the ductwork, accessories and the distribution boxes.



#### Galvanised Fixing Band

The galvanised fixing band ensure a steady installation of the duct. It is advised to use one band per 2 meters of duct run. Multiple bands can be connected with each other enabling compact installations with parallel duct runs.

