



# ETHOS 8500

## Multifunction Tester



# USER MANUAL



# INTRODUCTION

The Ethos 8500 Multifunction Tester has been designed and built to the highest standards providing you with a safe and simple solution to your test requirements.

The 8500 tester is used to verify the safety of Commercial, Domestic and Industrial installations. All testing is required to meet the latest edition of the wiring regulations (BS7671). The 8500 covers all aspects of these requirements with ease of use and safety in mind.

## CONFORMANCE WITH STANDARDS

**This tester complies with all the latest UK and European regulations.**

**This tester has been tested according to the following regulations:**

- ✓ BS EN 61010-2-030:2021 - Safety requirements for electrical equipment for measurement, control and laboratory use. Particular requirements for testing and measuring circuits.
- ✓ BS EN 61326-2-2:2021 - Electrical equipment for measurement, control and laboratory use. Particular requirements for portable test, measuring and monitoring equipment used in low-voltage distribution systems.
- ✓ BS EN 61557:2021 - Electrical safety in low voltage distribution systems up to 1000V AC and 1500V DC. Equipment for testing, measuring or monitoring of protective measures.
  - Part 1 : General Requirements
  - Part 2: Insulation Requirements
  - Part 3: Loop Requirements
  - Part 4: Continuity Requirements
  - Part 6: RCD Requirements
  - Part 7: Phase Rotation Requirements
  - Part 10: Multifunction Requirements

# ETHOS 8500 INSTRUCTION MANUAL

## MARKING EXPLANATIONS



**Warning!** Refer to manual.



**Caution! Voltage present.** Risk of Electric Shock.



**Earth**



**Double Insulation**



**This instrument should be recycled as electronic waste.**



**User accessible fuse in battery compartment** - F0.5A, 500V, HRC 6.3 x 32mm

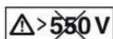

**Prohibited to use for the Electrical System which uses the voltage above 550V.**



**UK Conformity Assessed**



**Conformity to European Standards**

**CAT III / CAT IV** / CAT III Testers are designed to protect against transients and fault currents in fixed equipment installations at the distribution level. Examples are measurements on distribution boards and socket wiring.

CAT IV Testers are designed to protect against transients and fault currents from the primary supply level (overhead or underground utility service). Examples are measurements made before the main fuse or circuit breaker.

## SAFETY

- Before using the Ethos 8500 or accessories read this instruction manual carefully to ensure a safe understanding of the symbols and use of the tester.
- See the above list for explanations of symbols used on the product and in the manual.
- A warning identifies hazardous conditions and actions that could cause bodily harm or death.
- Caution identifies conditions and actions that could the instrument or cause permanent loss of data.

## WARNINGS READ BEFORE USING



### TO PREVENT ELECTRICAL SHOCK, FIRE OR INJURY:

- Use only specified Ethos accessories with the Ethos 8500. Part numbers of replacement leads on pg 4.
- If the equipment is used in a manner not specified by the manufacturer, the protection afforded by the equipment may be impaired.
- Disconnect from external circuits before removing battery cover.
- Inspect the tester and accessories for damage before use and do not use if damage is found.
- Do not use the product around explosive gas, vapour or in damp or wet environments.
- Do not use test leads if they are damaged. Examine the test leads for damaged insulation, exposed metal, and wear. If the white wear indicator shows replace the leads. Check the leads for continuity before use.
- To be repaired by Ethos authorised agents only.
- Do not apply more than the rated voltage between the terminals or between each terminal and earth ground.
- Do not operate the product with covers removed or the case open. Hazardous voltage exposure is possible.
- Use only specified replacement fuse. Fuse type F0.5A, 500V, HRC 6.3 × 32mm
- Keep fingers behind the finger guards on the probes at all times.
- Connect the common test lead before the live test lead and remove the live test lead before the common test lead.
- Use Personal Protective Equipment (approved insulated gloves, face protection, and flame-resistant clothes) to prevent shock and arc blast injury where hazardous live conductors are exposed.
- If cleaning is required use a damp cloth. Do not use abrasives or solvents. Do not allow any water ingress and ensure the tester is dry before use
- When replacing / removing the fuse from inside the battery bay, ensure all test leads are removed and the tester is switched off. Do not use sharp implements to remove the fuse.

# UNPACKING THE TESTER

Your Ethos Multifunction Tester comes complete with:

Description	Part No	Qty
Multifunction Tester	Ethos 8500	1
Instruction Manual		1
3 Wire Split Lead Assembly with Probes + Crocodile Clips Brown/Blue/Green	Ethos 2122	1
13 Amp Mains Lead to 4mm Connections Brown/Blue/Green	Ethos 2121	1
Remote Switch Probe	Ethos 2120	1
AA LR6 Alkaline Battery	Duracell	6
Heavy Duty Carry Case		1
Neck Strap		1
Certificate of Calibration		1

All the parts listed above are included in the carry case.

## OPERATING THE ETHOS 8500

To insert batteries ensure the instrument is switched off and no test leads are connected. Remove battery cover from base of unit, insert batteries into holder ensuring correct polarity and good connection to spring contacts.



Replace cover.

Always use good quality LR6 AA Alkaline Batteries.

Re-chargeable batteries are not suitable.

Battery power level indicated on the colour display by the symbol.

An icon consisting of five horizontal battery symbols stacked vertically, each with a different number of black bars representing charge level (5, 4, 3, 2, 1 bars from top to bottom). To the right of the batteries is a large, stylized lightning bolt symbol.

Please dispose of your batteries carefully.

Batteries are made from important resources and chemicals, including lead, cadmium, zinc, lithium and mercury. If batteries are disposed of as normal waste, they'll be taken to a landfill site and those resources will be lost and will contribute to the pollution of the environment. Recycling is one way you can help the environment and you should dispose of used batteries separately from other waste, using local collection and recycling schemes available.

## OVERVIEW

### Front panel and controls

A photograph of the front panel of the ETHOS 8500 Multi Function Tester. The device has a black and yellow color scheme. On the left, there is a 'TEST' button and a 'POLARITY-VOLTS PRESENT' indicator. The central LCD screen displays 'ETHOS' and '8500 v2.3'. Below the screen are four buttons labeled 'TEST', 'PFC/LOOP', 'INSULATION/SPD', and 'CONTINUITY NULL'. To the right of the screen is a large rotary selector knob with various settings including 'CONTINUITY', 'INSULATION', 'SPD/1000V', 'PHASE', 'OFF', 'SOCKET', 'NO TRIP', 'LOOP', 'HIGH I', 'EV', '30mA AUTO', '10mA', '30mA', '100mA', '500mA', 'RCD', 'AC/A/B', and 'ACS/AS'. There are also several indicator lights (green, red, blue, yellow) and a '500V' warning symbol.

### Top View

A photograph showing the top view of the ETHOS 8500 Multi Function Tester. The device is primarily yellow with a black base. On the front edge, there is a panel with four terminals: 'N' (Neutral), 'PE' (Protective Earth), 'L' (Line), and 'W' (Warning). Below these terminals are labels for 'MIN CAT II' and 'MIN CAT III'.

5

# OPERATING THE ETHOS 8500

All test Functions are selected by using the main rotary switch.

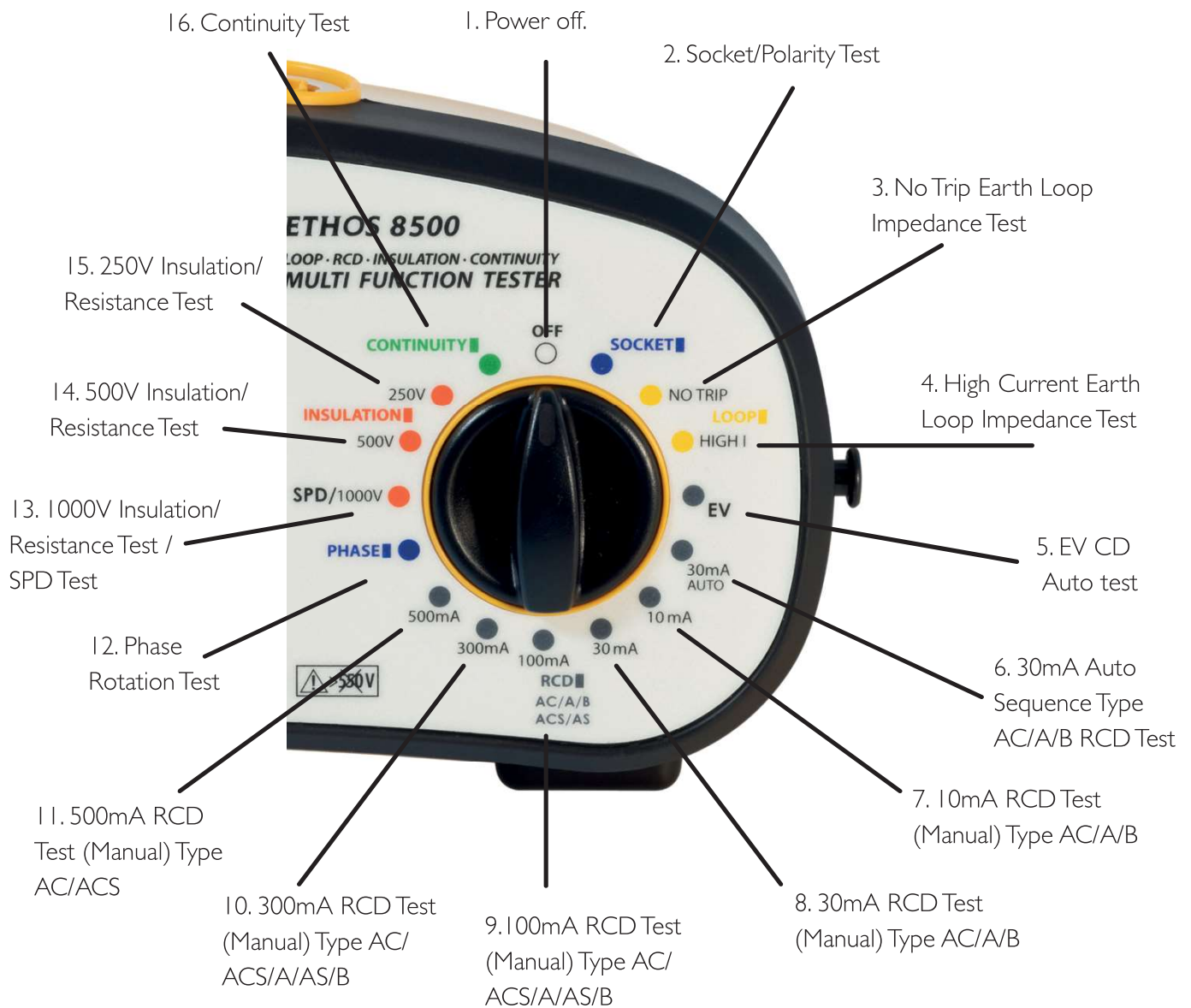

# OPERATING THE ETHOS 8500

## PUSH BUTTONS

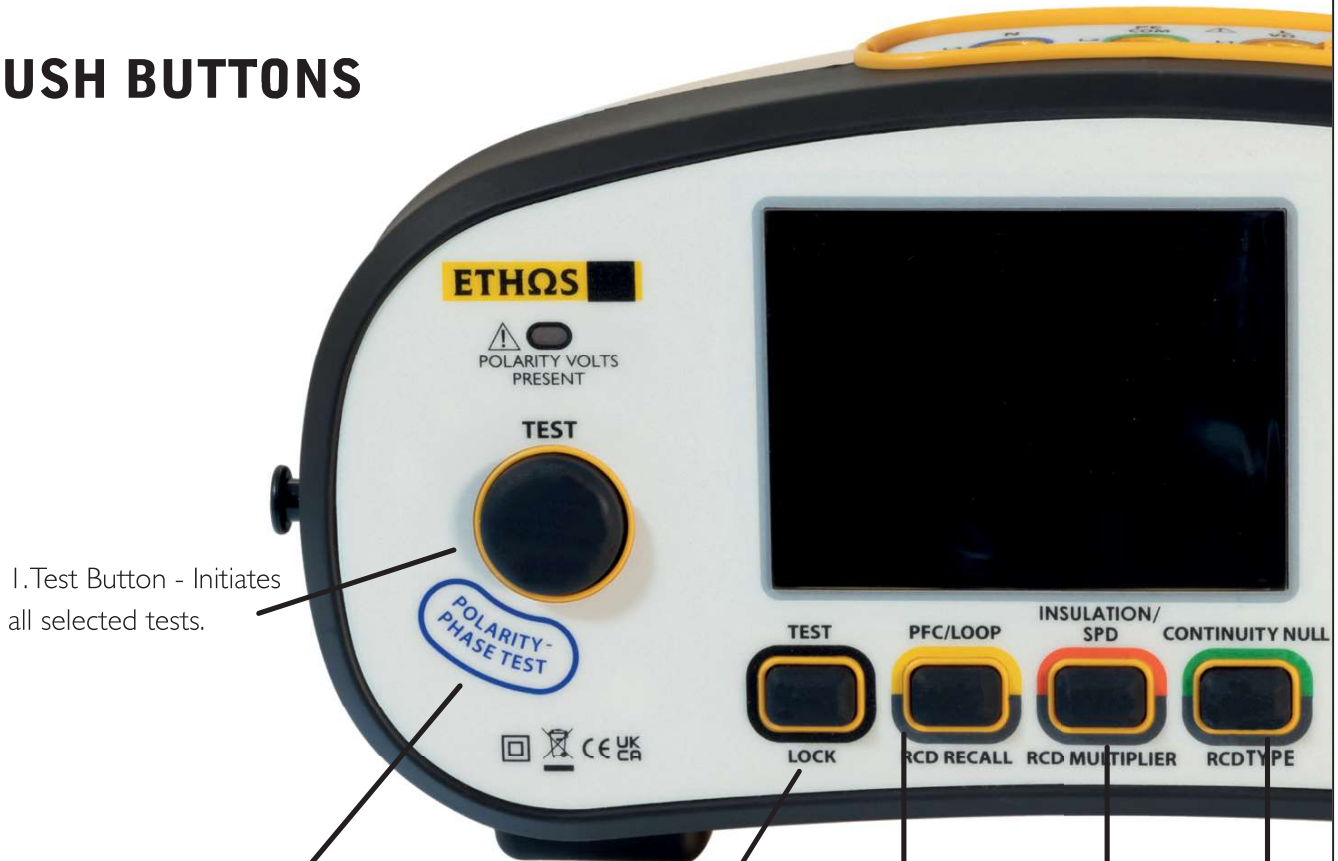

1. Test Button - Initiates all selected tests.

2. Polarity Test Pad - Unique safety function ensuring correct mains polarity

3. Test Lock- Hands Free function for Continuity, Insulation & Loop

4. PFC/Loop - Prospective fault current value after Loop Test Result  
RCD Recall - List the last set of RCD Test Data from an Auto sequence Test

5. Insulation / SPD – select between 1000V insulation test and SPD test  
RCD Multiplier – Select the RCD test current to be applied

6. Continuity Null - Nulls the Resistance Value from the Test Leads in use  
RCD Type – toggle between the types of RCD that can be tested

## AUTO POWER OFF FUNCTION

To ensure long battery life the 8500 will automatically power off when standing idle for 3 minutes. To power the 8500 either return the selector switch to "OFF" and then back to the test selection or simply press and hold any of the four buttons under the display screen.

# TEST & MEASUREMENT FUNCTIONS

## INSULATION, CONTINUITY AND SPD

### CAUTION

Measurements shall only be carried out on de-energized circuits.

If the tester is connected to a live circuit (25V or greater), the LED will flash red and the hazard buzzer will sound. Your Ethos 8500 is fully protected and the measured RMS voltage will be displayed on the secondary/ lower display. Further testing after this point will be inhibited. To resume testing, disconnect the test leads and isolate the circuit.

### CONTINUITY

### CAUTION

#### Principal of Measurement

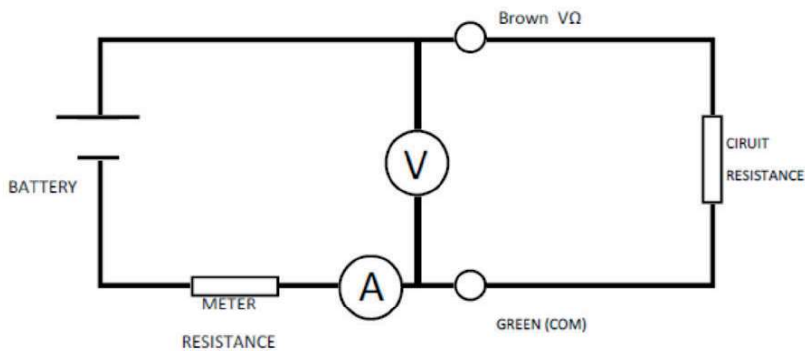

During continuity measurement current flows from battery positive through the Brown (VΩ) lead, external circuit resistance, Green (COM) lead, meter resistance and finally back to the battery negative. The current and voltage are measured as shown and the external resistance calculated. When the leads have previously been nulled, their resistance is subtracted before displaying the reading.

The purpose of Continuity Testing is to establish the resistance of the circuit under test.

## Test Procedure

Insert the brown test lead into the brown input terminal & the blue test lead into the green terminal.



The brown test lead can be substituted by using the red remote test probe supplied. This allows remote activation of the 8500 from the safety of the test probe ensuring that you are always looking at the point of contact and not the 8500.



Select continuity on the rotary switch.

## Lead Nulling

Test Leads are nulled to ensure accurate resistance values of circuit under test. To achieve this you must null the resistance of the leads in use. Using the croc clips connect the open ends of the test leads together firmly ensuring a good connection, then press continuity null button, the instrument will display the resistance value of the test leads, then press the test button, the display will then show  $0.00\Omega$  and your test leads are successfully nulled. The word Null will appear on the display.



**IMPORTANT – When connecting the croc clips they must be connected as diagram shown this ensures that the best point of contact is made to give the most accurate resistance value of the leads that will be used for testing**

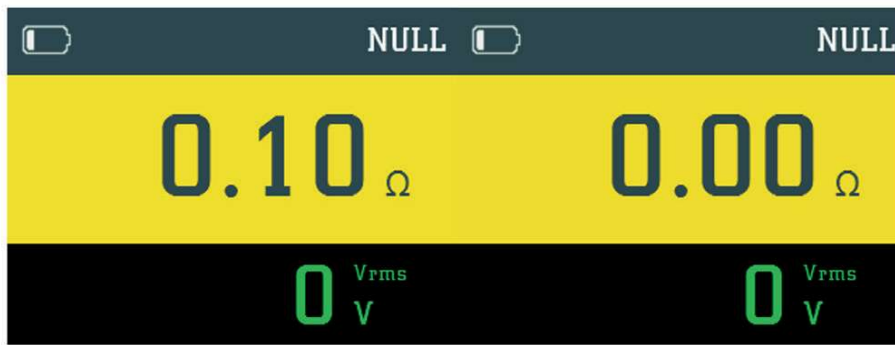

**Before Null**

**After Null**

**If inserting new or different length leads you must repeat process above.**

N.B. Nulled results will be stored until user reset. To reset simply leave the 8500 in continuity mode and open circuit i.e. do not have leads connected. Then press NULL this will then remove the null function.

The Ethos 8500 is now correctly set up to perform continuity testing on a circuit.

You can also set up your Ethos 8500 to be used in hands free mode on continuity by simply pressing the test lock button and then pressing test. T-Lock will flash at the top of the screen to indicate you are on hands free mode. To deactivate simply press test lock button again.

## **INSULATION / SPD**

### **CAUTION**



All equipment and appliances should be disconnected from the circuit under test. Attached equipment may be damaged by the higher voltages applied during testing and may return an artificially low test result. There may be capacitance on the circuit being tested. Your tester will automatically discharge this but do not disconnect the test leads or change tester function until auto-discharge has completed.

### **WARNING**



Do not touch the ends of the test leads while on the Insulation test / SPD functions as they are energised. Results of measurements can be adversely affected by impedances of additional operating circuits connected in parallel or by transient currents.

# PRINCIPLE OF MEASUREMENT

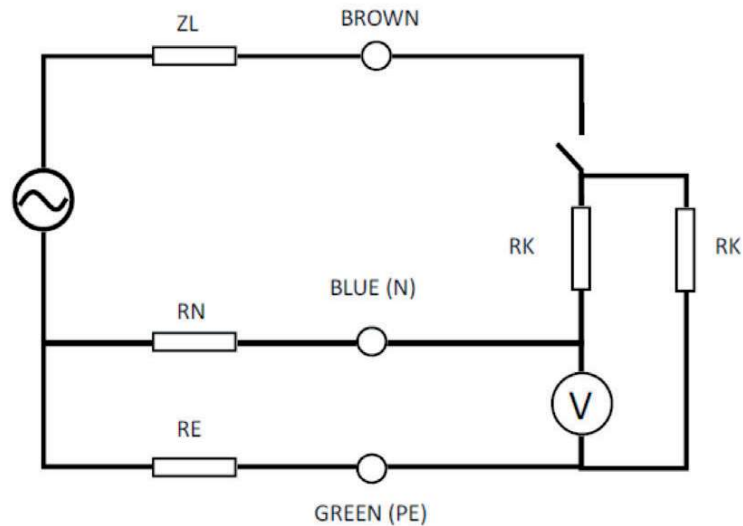

During insulation measurement the tester generates a high voltage internally. The positive side of this is connected to Brown ( $V\Omega$ ) lead causing a very small current to flow through the external insulation resistance, Green (COM) lead, meter resistance and finally back to the negative side of the HV generator. The current and voltage are measured as shown and the external resistance calculated and displayed.

## TEST PROCEDURE

Insert the brown test lead into the brown input terminal & the blue test lead into the green terminal.



The brown test lead can be substituted by using the red remote test probe supplied. This allows remote activation of the 8500 from the safety of the test probe ensuring that you are always looking at the point of contact and not the 8500.



Select insulation on the rotary switch either 250V, 500V, 1000V setting as required.

Connect the brown test lead to the phase conductor and the blue test lead to the other conductor under test and press the test button.

Press the test button, the tester will beep indicating voltage output through the test leads and the circuit under test. The display will indicate output voltage then display the result of test in M $\Omega$ . 0V output will indicate if finished and voltage present.

### Example Screens

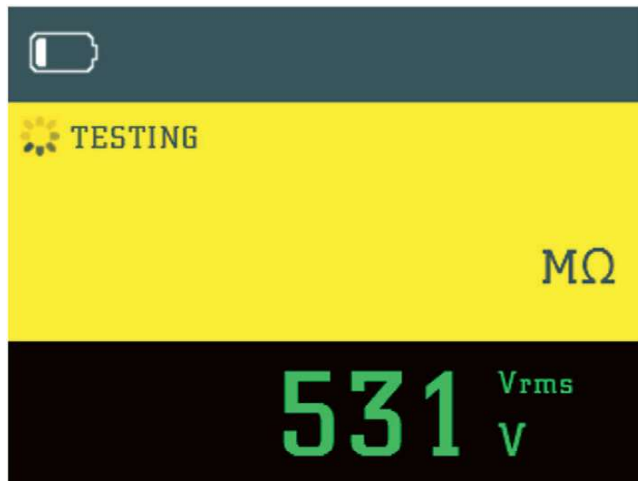

**Test in progress with voltage output**

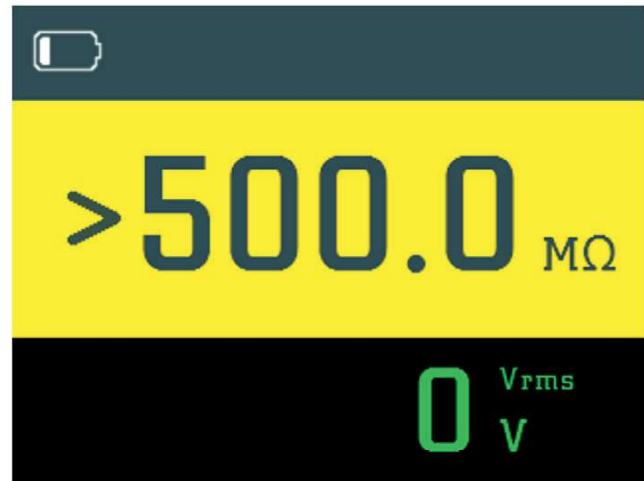

**Test result**

When test is activated the red Voltage/Polarity will flash warning there is voltage on the leads and circuit under test.

## HANDS FREE

Hands Free Insulation Testing.

To enable the hands free feature simply press Test Lock button once, The 'T-LOCK' annunciator will appear flashing on the display and will continue to do so until cancelled by a further press of the Test Lock button or by changing the function selector switch.

When the 'T-LOCK' annunciator is flashing a single press of the test button will toggle continuous testing on and off.

Once started a steady beeping tone will be emitted to indicate that measurement is being taken. After a second or two the test result will be displayed in the primary display area and an audible tone will indicate either by a single beep that the result is a value above 2M $\Omega$  or by a short 2 tone alarm that the result is a value under 2M $\Omega$ . The secondary display area will show the terminal voltage being applied.

The tester will continue to take the measurement and any further change to the resistance of the circuit will be indicated by an audible tone as described above and a change of result on the display.

Whilst testing in hand free mode the red warning LED will flash to warn of the voltage between the prod tips/ crocodile clips.

A further single press of the test button will suspend measurement.

## SPD TEST

Surge protection devices (SPD) are commonplace in installations to protect the installation and connected appliances from transient overvoltage.

The 8500 can test the SPD U<sub>c</sub> (The maximum voltage which may be applied to the SPD without it conducting).

## TEST PROCEDURE

Insert the brown test lead into the brown input terminal & the blue test lead into the green terminal. The brown test lead can be substituted by using the red remote test probe supplied.

Select the rotary dial to SPD / 1000V  
Press Insulation / SPD button.

SPD will be displayed on the screen.

Connect the brown test lead to L and the blue lead to N on the SPD.  
Press the test button.

The applied voltage will slowly ramp up until the SPD starts to conduct.  
The calculated AC voltage that the SPD conducts at will be displayed. The displayed AC voltage should read slightly higher than the advertised SPD L-N U<sub>c</sub>.  
Press the Insulation / SPD button to display the actual applied DC voltage.  
If the SPD fails to conduct the Ethos 8500 will show >1000V

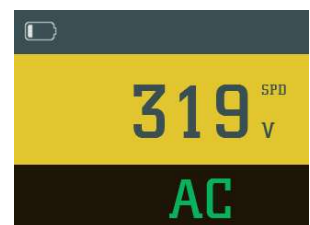
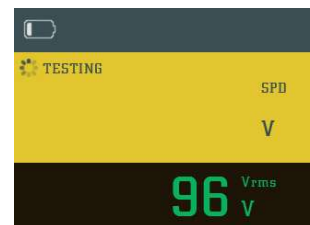

## SOCKET TESTING

The Ethos 8500 has a unique feature for testing sockets.

Switch the rotary dial to socket, insert 13 amp mains test lead and the brown, blue & green into the corresponding input terminals on the tester.



Plug the 13 amp mains plug into the socket under test. If there is no voltage present the following will be displayed.



If there is voltage present and the wiring is correct the following will be displayed.

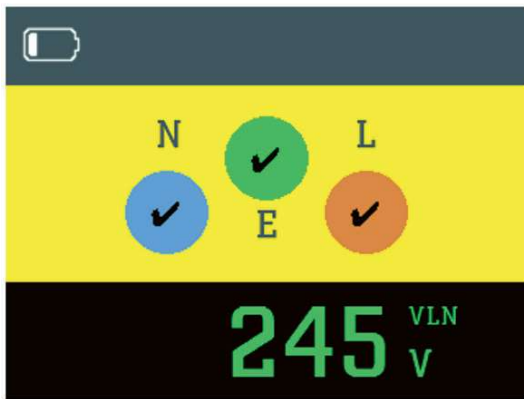

Correct wiring is indicated by a tick in each of the phase colours.

If there is incorrect wiring dependent on the issue the following screens will appear:



Reversed  
Live/Earth

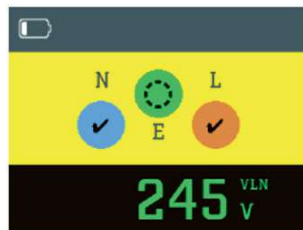

Missing Earth



Missing Neutral

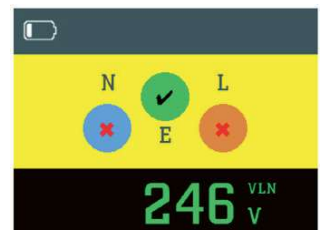

Reversed Polarity

## POLARITY TEST PAD



## Your Ethos 8500 tester has a special polarity test function.

It is a little known fact that a system can be reverse wired with Live (Phase) to earth/neutral and earth/neutral to Live (Phase). The sockets will all work and conventional testers will show and test that everything is correct despite this very dangerous wiring condition. Although extremely rare, this dangerous condition can exist so if your test shows this fault do not proceed - if in any doubt advise your customer to contact their supply company immediately.

With socket test selected on the rotary dial, touch the touchpad area next to the test button. There should be no change in the indication given. If the Voltage/Polarity LED flashes Red and a warning tone is emitted when the touchpad is touched a potentially dangerous polarity reversal exists. Do not proceed. If in any doubt advise the customer to contact the electricity supply company immediately.

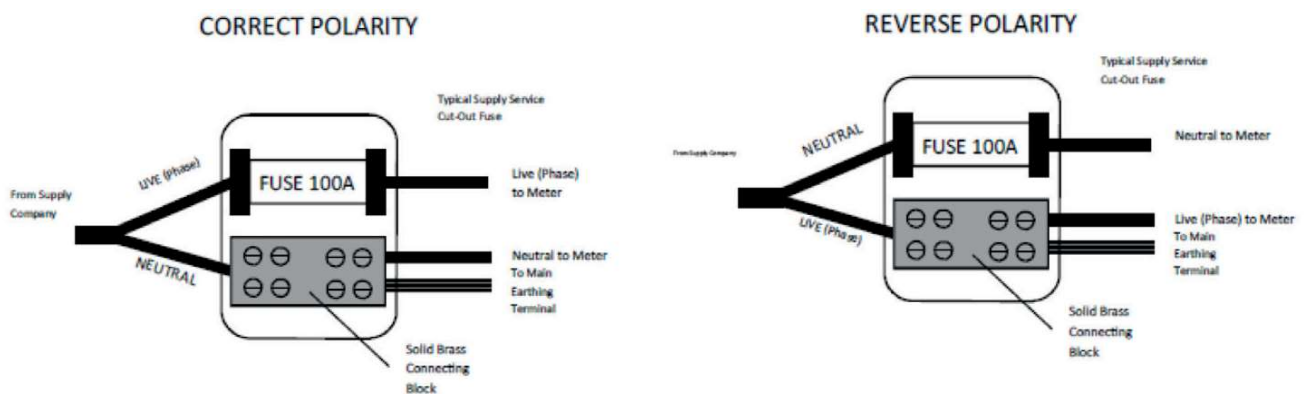

## LOOP IMPEDANCE TESTING

### CAUTION

Although fully protected against over voltage to 550VAC this tester should only be used on a 230V supply.

Important note for calibration check box users: The smart loop test system used by the Ethos 8500 is immune to sudden high value changes such as voltage spikes. As a result when changing calibration or check box loop values the tester or the supply must be switched off between changes of calibration values.

The Ethos 8500 Loop test function has 2 modes for Loop testing that allow the user to conduct the most accurate test possible depending upon whether or not the circuit under test is protected by an RCD.

# PRINCIPLE OF MEASUREMENT – HI I

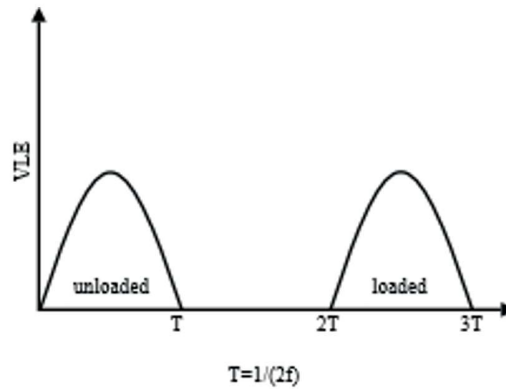
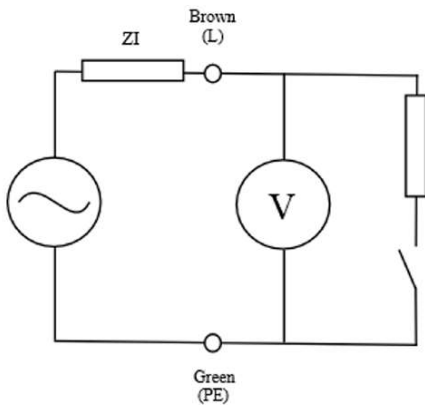

Hi-I Line – Earth loop measurement takes place in several steps:

- a) The tester measures an unloaded half cycle of the mains
- b) The tester switches in load  $R_L$ . This causes the mains circuit to be slightly attenuated due to the effective source impedance.
- c) The tester measures a second half cycle with the mains still loaded
- d) The load is removed

The resistive part of  $Z_I$  is calculated from the unloaded and loaded half cycle measurements. Each pair of measurements is taken adjacently to minimize noise and several such pairs may be used for best accuracy.

The inductive part of  $Z_I$  is calculated from the unloaded and loaded half cycle durations. Any inductance causes a measurable lag in the loaded half cycle.

NOTE: when testing on a supply with inductance exceeding 1mH or phase angle exceeding  $30^\circ$  accuracy may be reduced.

# PRINCIPLE OF MEASUREMENT – NO-TRIP

The No-Trip Line-Earth loop range measures the same circuit value  $Z_I$  using a two-stage technique.

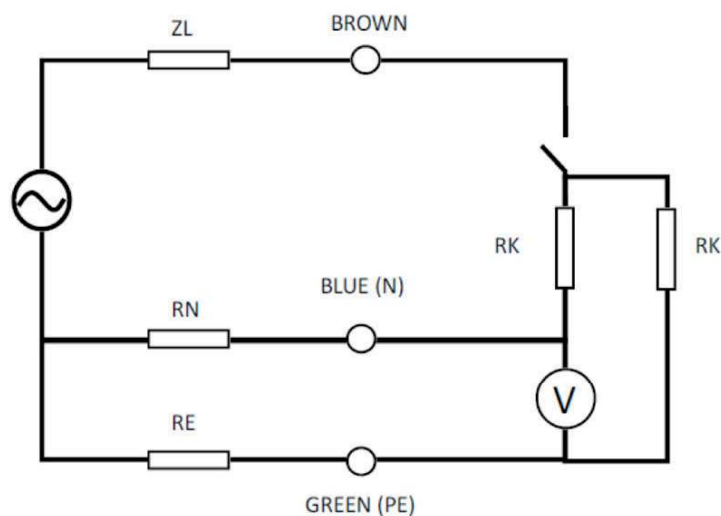

In the first stage the Live-Neutral loop impedance  $Z_{LN}$  is measured using the same principle as for Live-Earth loop.

The second stage is similar to Hi-I but operates at a low current to avoid tripping RCDs

# LOOP TEST PROCEDURES

## Mains supply wiring and voltage test

When first connected to a mains supply the Ethos 8500 will automatically conduct a safety test to ensure that the Live, Neutral and Earth conductors are all connected correctly and that the supply voltage is in the acceptable range (207 – 253V)

If all is well the VOLTAGE/POLARITY warning LED will light Green and the supply voltage will be displayed in the primary display area.

In the event of a problem with either the mains voltage supply or reversed connections the VOLTAGE/POLARITY warning LED will light Red, a warning tone will be sounded and testing will be inhibited.

This condition will be indicated for you safety.

## Hands Free Loop Testing

The hands free feature can be used in either No Trip or high current test modes.

To enable the hands free feature simply select the loop test required on the rotary dial then press Test Lock button once. The 'T-LOCK' annunciator will appear flashing on the display and will continue to do so until cancelled by a further press of the Test Lock button or by changing the function selector switch.

When the 'T-LOCK' annunciator is flashing all you need to do is connect the test lead to a mains supply and the test will be carried out.

## High Current mode

For Ze testing at the distribution board or at any point upstream of RCD protection there is a traditional fast high current test mode. The high current mode is a 2-wire test that enables the user to test the true impedance of both the Line-Neutral Loop and the Line-Earth loop and therefore to establish both the PSC (prospective short circuit current) and the PFC (prospective fault current) for the installation.

Unlike most testers that only measure the resistance of the Loop, the high current mode of the Ethos 8500 will measure the impedance of the Loop which includes an element of reactance. This can be significant where the distribution board is close to the mains supply transformer and is therefore much more accurate than older Loop testing techniques.

You should be aware that because of this there may well be variations in reading compared to ordinary loop testers or to the non-trip function of this tester; particularly when the measurement is made near to the mains supply transformer.

## **No Trip Mode**

For Zs testing where the circuit being tested is protected by an RCD there is the No Trip Loop Test mode. In this mode testing can be made at sockets on the final circuit without fear of tripping the RCD under normal circumstances.

This is achieved by testing at a current that is too low to trip an RCD on an otherwise healthy circuit. The No Trip test is a 3-wire test that also checks the Live, Neutral/Earth conductors are correctly connected before running the loop test.

Note- if there is abnormal standing leakage current on the circuit such as a faulty Microwave Cooker for example then this abnormal leakage is added to low current used for the above test and the RCD may trip.

However this can be seen as an advantage since it is pointing to a faulty appliance that should be rectified or replaced.

Whilst No-Trip testing at points on the final circuit will normally function with a high level of accuracy, it should be noted that the low current measurement technique used is more likely to be adversely affected by external factors such as noise on the mains supply.

Circumstances such as testing at seldom used socket outlets with tarnished contacts or testing a circuit with a lot of background noise from electronic apparatus can result in the occasional erroneous reading.

For this reason it is recommended that multiple measurements are made when using the No-trip mode and any isolated odd results are ignored. When taking multiple readings the tester should be disconnected from the supply between consecutive tests.

For safety reasons the No-Trip mode is recommended for all measurements made on TT systems.

Where practical all other equipment powered by the same circuit should be switched off before testing. This will reduce the chances of the RCD tripping as a result of combined leakages.

## **PFC/PSC**

In both Loop test mode the Ethos 8500 will also display the supply voltage and at the touch of the PFC button the PFC/PSC depending on being connected L-E or L-N will be displayed

## **Test lead configuration**

The Ethos 8500 Loop test function can be used with 2 types of connecting lead. It is important to understand and use the correct lead configuration for each test mode or you may not obtain the correct results.

Lead options

Ethos 2121 mains lead with 3 x 4mm plug to 13A plug

Ethos 2122 3-pole distribution board test lead set that can be fitted with either prod tips or crocodile clips as required.

2 Wire lead configuration Brown (live) Blue(neutral) Green (earth) The neutral is inserted into the back of the earth lead to give a combined contact for 2 wire test method.



The brown test lead can be substituted by using the red remote test probe supplied. This allows remote activation of the 8500 from the safety of the test probe ensuring that you are always looking at the point of contact and not the 8500.



### High current test (Ze)

The high current should only be conducted with the distribution board test lead set Ethos 2122 configured in 2 wire mode. Do not use this function with the Ethos mains lead 2121 or the distribution lead set in 3-wire configuration.

Rotate the function selector to the HIGH I position.

Connect the test lead probes to the circuit under test and press the test button.

The result will be shown in the primary display and the mains voltage will be shown in the secondary display.

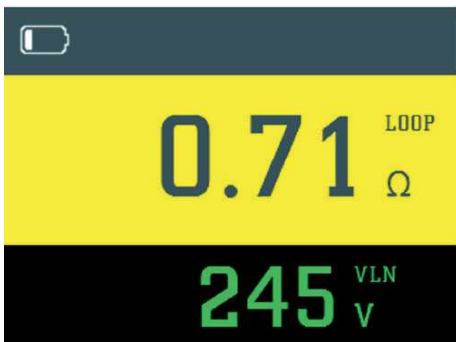

Press the PFC/LOOP button to show the PFC/PSC in the primary display depending on being connected L-E or L-N and the impedance in the secondary display area.

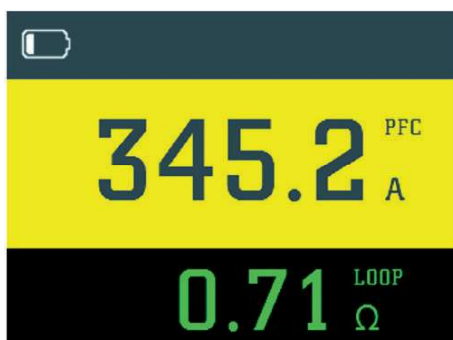

Note: The reading described here as PFC/PSC will be the prospective fault current for the circuit being immediately tested. This is known as PSC in the case of a test between Live and Neutral or PEFC for a test between Live and Earth conductors.

### No Trip Loop test (Zs)

Connect the brown, blue and green test leads to the corresponding output terminals on the tester.



The brown test lead can be substituted by using the red remote test probe supplied. This allows remote activation of the 8500 from the safety of the test probe ensuring that you are always looking at the point of contact and not the 8500.



If testing the loop impedance at a socket plug in the 13amp plug and switch on the power:

N.B. The circuit under test must be live to loop testing. The test will be inhibited if the wiring is incorrect polarity on the circuit under test.

Rotate the function selector switch to 'NO TRIP'

Connect the test lead to the socket/circuit under test.

Providing that the connections are correct and the supply voltage is within the correct range the VOLTAGE/ POLARITY LED will light Green, the Ethos 8500 will start taking some background measurements and will display the Line Neutral supply voltage

Voltage will be displayed. Then press the test button. The screen will show a symbol and the word testing.



The result of the test will be shown in the primary display.

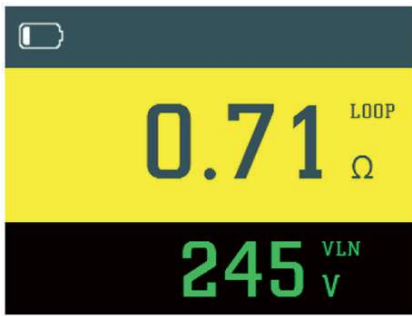

A single press of the PFC Loop button will toggle the display so that the PFC is shown in the primary display and the impedance in the secondary display. A further press will toggle the results between the primary and secondary displays.



The leads are an integral part of the tester set-up and should accompany the tester when being returned for re-calibration or service. Do not use any other type of mains lead or test lead set.

## INTERMITTENT OPERATION

The Ethos 8500 is designed for a large number of loop tests in rapid succession. In the unlikely condition this limit is exceeded a thermometer will be shown on the display until the unit cools down. Testing will be inhibited while the thermometer is shown.

## RCD

### WARNING



Leakage currents in the circuit following the residual current protection device may influence the measurements.

Potential fields of other earthing installations may influence the measurement.

Special conditions in S-type residual current protective devices shall be taken into consideration.

Equipment connected downstream of a residual current protective device (RCD) may cause considerable extension of the operating time. Examples of such equipment might be connected capacitors or running motors.

## PRINCIPLE OF MEASUREMENT – X1/2, X1, X5

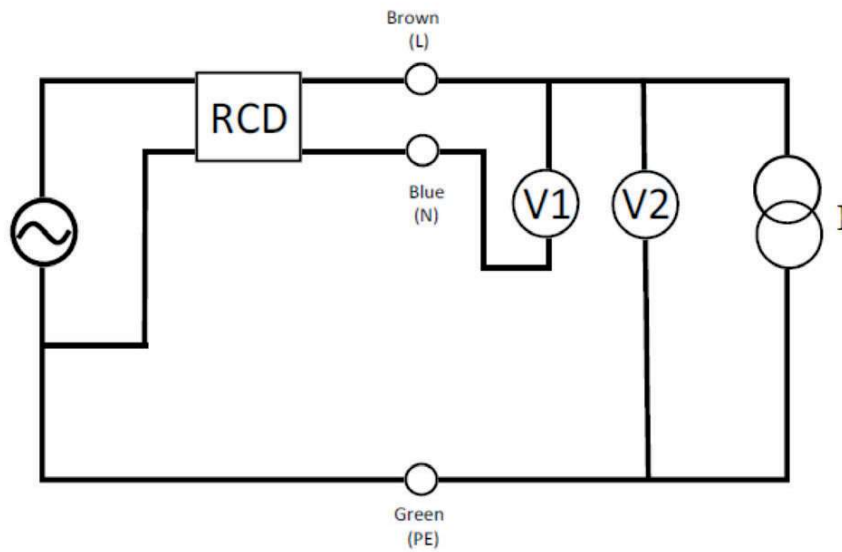

During normal RCD test an earth leakage current  $I$  is applied to unbalance the RCD.

During application of the current,  $V_{LN}$  is monitored using voltmeter  $V_1$  for an RCD trip signature. When trip occurs, the time from application of the earth leakage current to the trip is calculated and displayed.

Additionally,  $V_{LE}$  is measured using voltmeter  $V_2$  to monitor Fault Voltage. If excessive Fault Voltage is detected, testing is aborted and a warning is displayed. This detection uses the actual Fault Voltage occurring during the test and not the predicted fault voltage at the rated residual current.

Application of the current is limited in duration. If no trip is detected during the application, an over range reading is displayed. Note: when testing at  $\times 1/2$ , no trip is a PASS.

## PRINCIPLE OF MEASUREMENT – RAMP

During RCD Ramp testing, the earth leakage current starts at 20% of RCD rated current and increases by 10% of RCD rated current every 300ms up to a maximum of 110%. For example a 30mA Ramp test runs from 6mA to 33mA.

The trip time is measured as in the normal case and the trip level calculated from it.

# RCD TEST FUNCTION

## CAUTION

Although fully protected against over voltage to 550VAC this tester should only be used on a 230V supply.

The Ethos 8500 will test all the most commonly encountered AC, A and B RCD types. It also has an EV (electric vehicle) setting that allows testing of 6mA RDC-DD that are commonplace on EV charge points.

In addition to the required  $\times 1$  test, the 8500 allows  $\times 1/2$ ,  $\times 5$  and ramp tests to help when fault finding. For the most commonly used 30mA RCD an auto test is available that conducts a full suite of tests ( $\times 1/2$ ,  $\times 1$ ,  $\times 5$ ).

For the reasons explained below all RCD tests have to be conducted at both  $0^\circ$  and  $180^\circ$  (positive and negative polarity for type B) this means that two tests have to be made for each RCD test.

### **Sinusoidal polarity (the $0^\circ$ or $180^\circ$ test)**

RCD's often operate with different reaction times depending upon whether the fault is introduced during the positive or negative half cycle of the AC waveform (positive or negative polarity for type B). Therefore to accurately determine the maximum response time of an RCD it is necessary to test it twice at each given fault current, firstly with the fault introduced during the positive half cycle and secondly during the negative half cycle.

The Ethos 8500 takes care of this for you by alternating the start point of consecutive tests at any given setting. If you have selected a test at the rated trip current ( $\times 1$ ) of a 100mA RCD, the first press of the test button will apply a 100mA fault current starting on the positive half cycle ( $0^\circ$ ) and display the result. A further press of the test button will carry out another test at the same current but starting on the negative half cycle ( $180^\circ$ ).

### **Test Leads**

Where testing is to be conducted at a point on the circuit other than a socket outlet the distribution board test lead set Ethos 2125 is used in 3-wire mode as described in the previous chapter. The probes can be fitted with either prod tips or crocodile clips as required.

## Mains supply wiring and voltage test

When first connected to a mains supply the Ethos 8500 will automatically conduct a safety test to ensure that the Live, Neutral/Earth conductors are correctly connected and that the supply voltage is in the acceptable range of 207-253V.

If all is well the VOLTAGE/POLARITY warning LED will light Green and the supply voltage will be displayed in the primary display area.

In the event of a problem with either the mains voltage supply or reversed connections the VOLTAGE/POLARITY warning LED will light Red, a warning tone will be sounded and testing will be inhibited.

## RCD test procedure

Select the rating of the RCD to be tested with the rotary function selector switch.

Select the required RCD type with the RCD Type button.

Select the required test current with the RCD multiplier button.

Connect the 4mm plugs of the chosen test lead to the corresponding L, N & E terminals of the Ethos 8500 and connect the other end to the socket or circuit terminals under test.

If using the distribution board test lead set Ethos 2122 observe the correct polarity by connecting the Brown probe to the Live conductor, Blue to Neutral and Green to Earth.

The default test parameters of  $\times\frac{1}{2}$   $\times 1$   $\times 5$  for the current multiplier and  $0^\circ$  for the phase polarity will be automatically selected for the first test. These will be displayed on the LCD along with the Live-Neutral voltage.

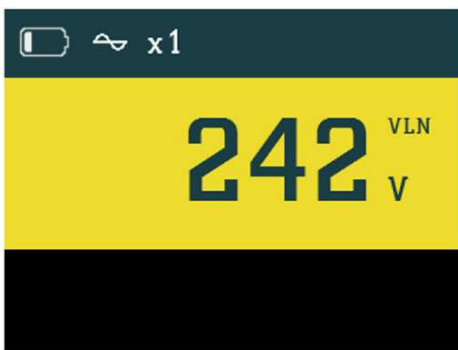

Press the test button and a test will be conducted at these settings. If successful and the RCD has tripped a single beep will sound and the main display will be similar to this example

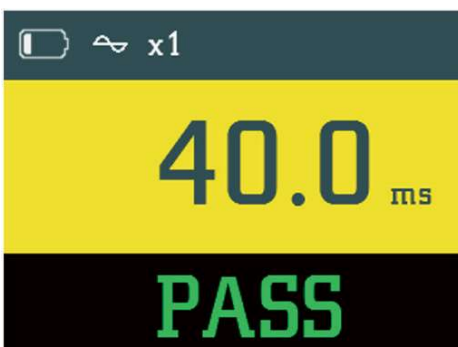

## Automatic test

For the most commonly encountered 30mA RCD the test process is even simpler. Just turn the rotary selector to the '30mA AUTO' setting, select the RCD Type and the Ethos 8500 will conduct all six required tests at a single touch of a button. Then when the RCD under test "trips" reset the RCD and continue to do so until the test procedure is complete then return to your 8500 where all results will be displayed on one screen.

VLN: 245V			
30mA x1/2		>2000ms	PASS
30mA x1/2		>2000ms	PASS
30mA x1		40.0ms	PASS
30mA x1		50.0ms	PASS
30mA x5		10.0ms	PASS
30mA x5		20.8ms	PASS

## Pass or Fail result

In addition to displaying the time taken for the RCD to trip the Ethos 8500 will also indicate whether it has passed or failed the test.

The main display shows that the fault current was supplied for over 2000 milliseconds (2 seconds) without tripping the RCD.

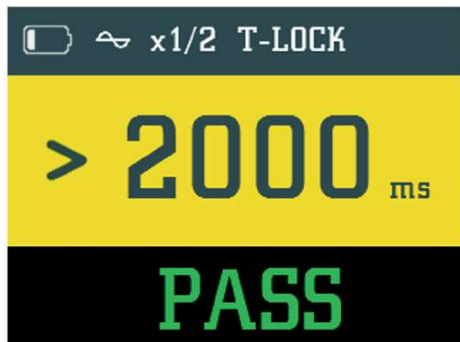

In the event of the RCD failing the test and tripping within 2 seconds at half the rated current the main display will show the trip time and the secondary display will show 'FAIL'. A short 2 tone alert will also sound.

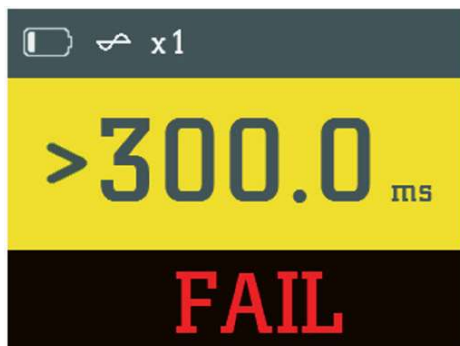

After displaying the result for a few seconds the tester will switch to the 180° phase polarity setting in readiness for the next test.

When both tests have been conducted at the x $\frac{1}{2}$  setting press the multiplier button to change the test current to the x1 setting.

Press the test button to conduct a test at the x1 setting a 0°. The result will be shown as a pass if RCD trips within 300ms. After displaying the result for a few seconds the tester will switch to the 180° phase polarity setting in readiness for the second test at the x1 current setting.

If the 10mA or 30mA setting has been selected the x5 current option will be available by using the multiplier button.

### Ramp test

The Ethos 8500 also includes a diagnostic Ramp test feature. In this mode rather than applying a steady fault current and measuring the time taken for the RCD to trip, the Ethos 8500 gradually increases the fault current and identifies the level of additional leakage at which the RCD trips.

This is particularly useful in diagnostic testing of circuits where nuisance tripping is a problem and helps to identify the difference between an over sensitive RCD and excessive leakage from poor insulation or equipment with high leakage.

Use the rotary switch to select the rating of the RCD.

Use the RCD Type button to select the type of RCD

Press the RCD multiplier button until the symbol ▲ is displayed.

Press the test button to start the test. The fault current applied will increment in 3mA steps until the RCD trips.

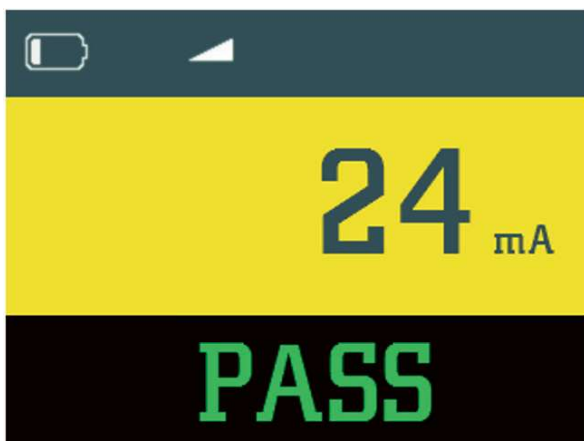

If nuisance tripping on a circuit is a problem this function can be used to retest the RCD with other appliances systematically connected and removed.

For example a 30mA RCD may trip at 12mA on ramp test with an appliance connected and then at 27mA with the appliance removed. You will know that the appliance is leaking approximately 15mA.

### EV test

As most EV charge points are protected by type A RCD and 6mA RCD-DD Your Ethos 8500 has an EV Auto test this.

Use an EV adaptor such as the Ethos 8600 to energise the EV charge point. Connect the Ethos 8500 to the EV adaptor using either the 13Amp plug lead or distribution board leads in three wire mode.

Select EV on the rotary selector switch.

If the EV charge point is online the main display will show Voltage L-N

The first test to be completed is the 6mA RDC-DD test. this can either be a x1 test that shows the time that the RDC-DD takes to operate or a ramp test that will indicate at what current the RCD-DD operates at.

To select ramp is the default setting. To select x1 press the RCD Multiplier button.

Pressing the test button will then initiate the Auto test

A total of 8 tests will be carried out.

6mA DC -

6mA DC +

30mA x1/2, 0°

30mA x1/2, 180°

30mA x1, 0°

30mA x1, 180°

30mA x5, 0°

30mA x5, 180°

After the tests have been completed the results will all be shown on one screen.

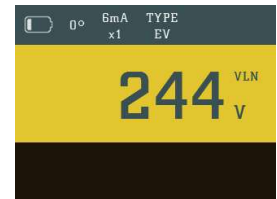
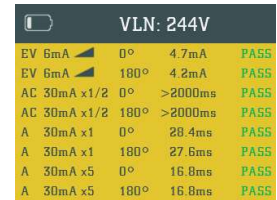
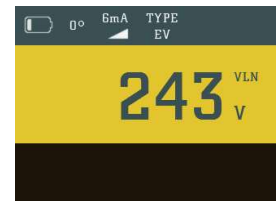

## PHASE ROTATION

## PRINCIPLE OF MEASUREMENT

During phase rotation measurement the amplitudes and phase angles of the three inputs L1 L2 L3 are checked against limits, allowing for mild unbalance conditions. The indication 1-2-3 is displayed for normal rotation (L2 lags L1) and 3-2-1 for reverse rotation (L2 leads L1).

Display of Phase rotation is Automatic when all three tests leads are connected to the 3 phase supply as below:

Set the main rotary switch phase

Using three test leads, connect test leads to the L1 to Phase 1, L2 to Phase 2 and L3 to Phase

The Ethos 8500 will display .1 .2 .3 or .1 .3 .2 depending on the direction of phase rotation.

## WARNING

Only use LR6 Alkaline replacement batteries.

Please dispose of your batteries carefully.

Batteries are made from important resources and chemicals, including lead, cadmium, zinc, lithium and mercury. If batteries are disposed of as normal waste, they'll be taken to a landfill site and those resources will be lost and will contribute to the pollution of the environment. Recycling is one way you can help the environment and you should dispose of used batteries separately from other waste, using local collection and recycling schemes available.

# GENERAL SPECIFICATIONS

Dimensions	H 115mm W 245mm D 140mm
Weight (With Batteries)	980g
Battery Type	6 × AA / LR6 Alkaline
Battery Life (Typical)	Idling : 13.5 hours Insulation according to BS EN61557-2: 1008 tests Continuity according to BS EN61557-4: 960 tests
Protective Device	F0.5A, 500V, HRC 6.3 × 32mm
LCD Display	TFT (Thin-Film-Transistor) Colour LCD 3.5" Diagonal 320xRGBx240 pixels
Category Rating	300V CAT IV 600V CAT III
Ingress Protection Rating	IP54
Operating Temperature	0°C to 40°C
Storage Temperature	-10°C to 60°C
Operating Humidity	80% @ 31°C to 50% @ 40 °C
Operating Altitude	0 to 2000m

# MEASUREMENT SPECIFICATIONS AND ACCURACIES

## LOOP / PFC-PSC

### High Current

2 wire test Live – Earth or Phase - Phase, 7A nominal at 230V.

Measurement Range	Accuracy	System Voltage Range	System Voltage Frequency	Over Voltage Protection (BS EN 61557-10)
0.00 Ω to 500.0 Ω	± (3% + 3 digits)	100 - 440 V ac	50-60 Hz	550V

### No Trip

3 wire test Live-Earth, 13 mA nominal at 230V, max 5Ω Neutral impedance.

Measurement Range	Accuracy	System Voltage Range	System Voltage Frequency	Over Voltage Protection (BS EN 61557-10)
0.00 Ω to 500.0 Ω	± (5% + 5 digits)	195 - 253 V ac	50-60 Hz	550V

## Insulation

Test Voltage	Measurement Range	Accuracy	Short Circuit Current (into 2K $\Omega$ )	Over Voltage Protection (BS EN 61557-10)
250V	0.001 to 200.0 M $\Omega$	$\pm$ (3% + 2 digits + 10%/G $\Omega$ )	< 2 mA	550V
500V	0.001 to 500.0 M $\Omega$	$\pm$ (3% + 2 digits + 5%/G $\Omega$ )	< 2 mA	500V
1000V	0.001 to 1000 M $\Omega$	$\pm$ (3% + 2 digits + 2.5%/G $\Omega$ )	< 2 mA	500V

## Output Voltage

Voltage	Load	Accuracy	Output Current	Short Circuit Current (into 2K $\Omega$ )
250V	250 k $\Omega$	-0% +20%	1 mA	<2 mA
500V	500 k $\Omega$	-0% +20%	1 mA	<2 mA
1000V	1 M $\Omega$	-0% +20%	1 mA	<2 mA

## SPD test

Range	1000V
Display range	1049V
Measuring range	0 - 1049V
Accuracy	$\pm$ 5%rdg $\pm$ 5dgt
Voltage increase rate	100V / sec
Voltage increase step	1V
Threshold value for current detection	1mA

## Continuity

Measurement Range	Accuracy	Open Circuit	Short Circuit Current (at 2 $\Omega$ )	Max Lead Null Resistance	Over Voltage Protection
0.00 $\Omega$ to 19.99 k $\Omega$	$\pm$ (3% + 2 digits)	> 4V < 10V	> 200 mA	4 $\Omega$	550V Fused

## RCD

System Voltage Range	System Voltage Frequency	Nominal Currents	Short Circuit Current (at 2Ω)	Max Lead Null Resistance	Over Voltage Protection (BS EN 61557-10)
195 – 253 V ac	50-60 Hz	6 (EV), 10, 30, 100, 300, 500	50 V	± (1% + 1ms)	550 V

## Accuracy at Applied Test Current

Test Current	Accuracy
½	+0% -10%
× 1	+10% -0%
×5 (10mA, 30mA only)	+10% -0%
▲ (Ramp)	± 5% of rated $I_N$

Ramp Characteristics: 20% to 110% of rated  $I_N$  in 10% steps (300ms dwell time)

EV Ramp Characteristics: 30% to 100% of rated  $I_N$  in 2% steps (10s dwell time)

## RCD Capability

### X1/2

mA	AC	ACS	A	AS	B
10	Y	N	Y	N	Y
30	Y	N	Y	N	Y
100	Y	Y	Y	Y	Y
300	Y	Y	Y	Y	Y
500	Y	Y	N	N	N

### X1

mA	AC	ACS	A	AS	B
10	Y	N	Y	N	Y
30	Y	N	Y	N	Y
100	Y	Y	Y	Y	Y
300	Y	Y	Y	Y	Y
500	Y	Y	N	N	N

## X5

mA	AC	ACS	A	AS	B
10	Y	N	Y	N	Y
30	Y	N	Y	N	Y
100	N	N	N	N	N
300	N	N	N	N	N
500	N	N	N	N	N

## Ramp

mA	AC	ACS	A	AS	B
10	Y	N	Y	N	Y
30	Y	N	Y	N	Y
100	Y	Y	Y	Y	Y
300	Y	Y	Y	Y	Y
500	Y	Y	N	N	N

## Operating Ranges and Uncertainties According to EN 61557

Function	Display Range	EN 61557 Measurement Range	EN 61557 Operating Uncertainty	Nominal Values
<b>Insulation Resistance EN 61557-2</b>	0.001 M $\Omega$ - 1000M $\Omega$	0.1M $\Omega$ – 1000M $\Omega$	1.6%	$U_N = 250 / 500 / 1000$ V dc $I_N = 1.0$ mA
<b>Loop Impedance EN 61557-3</b>	0.01 $\Omega$ - 500 $\Omega$	1.04 $\Omega$ - 470 $\Omega$	Hi-I: 4.8% No-Trip: 10.8%	$U_N = 230/400$ V ac f = 50/60 Hz
<b>Continuity EN 61557-4</b>	0.00 $\Omega$ – 20k $\Omega$	0.1 $\Omega$ - 10k $\Omega$	12%	4.0V dc < $U_Q$ < 24V dc $R_{LO} \leq 2.00\Omega$ $I_N \geq 200$ mA
<b>RCD EN 61557-6</b>	$\Delta T$ : 5ms – 2000ms	$\Delta T$ : 38.2ms – 214.8ms	$\Delta T$ : 2.8%	$I_{\Delta N} = 30 / 100 / 300 / 500$ mA
	$I_{\Delta N}$ -	$I_{\Delta N}$ : 15mA – 500mA	$I_{\Delta N}$ : 7.2%	

## Operating Uncertainties

<b>Influence Quantity</b>	<b>Insulation Resistance <math>R_{ISO}</math> EN 61557-2</b>	<b>Loop Impedance <math>Z_I</math> EN 61557-3</b>	<b>Continuity RLO EN 61557-4</b>	<b>RCD <math>\Delta T</math> EN 61557-6</b>	<b>RCD <math>I_{\Delta N}</math> EN61557-6</b>
<b>A – Intrinsic Uncertainty</b>	0.8%	0.9%	1%	1.5%	5.6%
<b>E<sub>1</sub> – Position</b>	0%	0%	0%	0%	0%
<b>E<sub>2</sub> – Supply Voltage</b>	1.0%	0.8%	10%	1.2%	0.3%
<b>E<sub>3</sub> - Temperature</b>	0.8%	4.9%	0.7%	2.0%	2.1%
<b>E<sub>6</sub> – System Phase Angle</b>	-	2.4%	-	-	-
<b>E<sub>7</sub> – System Frequency</b>	-	0.4%	-	-	-
<b>E<sub>8</sub> – System Voltage</b>	-	1.4%	-	1.5%	0.6%
<b>E<sub>9</sub> – System Harmonics</b>	-	0.8%	-	-	-
<b>E<sub>10</sub> – System D.C Quantities</b>	-	8.4%	-	-	-

# LIMITED WARRANTY AND LIMITATION OF LIABILITY

Each ETHOS product is warranted to be free from defects in material and workmanship under normal use and service. The warranty period is three years and begins on the date of purchase. Parts, product repairs, and services are warranted for 90 days. This warranty extends only to the original buyer/end user customer of an ETHOS authorized reseller; and does not apply to fuses, disposable batteries, or to any product which, in ETHOS opinion, has been misused, altered, neglected, contaminated, or damaged by accident or abnormal conditions of operation or handling.

ETHOS authorized resellers shall extend this warranty on new and unused products to end user customers only but have no authority to extend a greater or different warranty on behalf of ETHOS. Warranty support is available only if the product is purchased through an ETHOS authorized sales outlet.

ETHOS warranty obligation is limited, at ETHOS option to repair product free of charge, replacement of a defective product, refund purchase price which is returned to an ETHOS authorized service centre within the warranty period.

To obtain warranty service contact your nearest ETHOS service centre to obtain return authorization information then return the product to that service centre with a description of fault. Following warranty repair the product will be returned to the authorized centre and in turn they will return the repaired product back to the end user. If ETHOS determines that failure was caused by neglect, misuse, contamination, alteration, accident, or abnormal condition of operation or handling, including overvoltage failures caused by outside the products specified rating, or normal wear and tear of mechanical components, ETHOS will provide an estimate of repair and obtain authorization before commencing the work.

This warranty is buyers sole and exclusive remedy and is in lieu of all other warranties, express or implied, including but not limited to any implied warranty of merchantability or fitness for a particular purpose. ETHOS shall not be liable for any special, indirect, incidental or consequential damages or losses.

ETHOS Instruments  
Distributed by MTi  
Boundary Road,  
Avonmouth,  
Unit 12  
Access 18,  
Bristol  
BS11 8HT

Tel: 0117 938 6400

Fax: 0117 923 5374

Email: [enquiries.ethos@adivision.co.uk](mailto:enquiries.ethos@adivision.co.uk)

Web: [www.ethos-instruments.co.uk](http://www.ethos-instruments.co.uk)

REGISTER YOUR PRODUCT at [www.ethos-instruments.co.uk](http://www.ethos-instruments.co.uk) - click on "Register a Product"



Waste electrical products should not be disposed of with household waste. Please recycle where facilities exist. Check with your local authority or retailer for recycling advice.

# ETHOS

## **Distributed by MTi**

Unit 12, Access 18, Bristol BS11 8HT

Tel: 0117 938 6400

Email: [enquiries.ethos@adivision.co.uk](mailto:enquiries.ethos@adivision.co.uk)

Web: [www.ethos-instruments.co.uk](http://www.ethos-instruments.co.uk)

ISSUE 1: 12/22