

UMBRA PROFESSIONAL IP65

Professional IP65 Weatherproof Batten, DALI

- Smartest and most feature inclusive batten on the market. Provides long life and unrivaled control.
- Flicker-free dimming throughout the dimming range which allows light level adjustment to gain maximum power savings.
- IP65 weatherproof rating and IK08 impact rating.
- LED lifetime >102,000 hours (L70), >102,000 hours (L80) and 55,000 hours (L90).
- 12 years design life at max. ambient
- Full support for DALI and DALI-2 (IEC 62386) DT6 (LED).
- Emergency models fully compliant (AS/NZS 2293.3) and supports DALI DT1 (EM).
- Soft-start battery charger to reduce building load, allowing the building to stabilize before adding additional load.
- High quality lithium battery (LiFePO4) and smart charger to ensure long battery service life.
- Power monitoring (DT51) allows control systems to monitor and report active power and total power consumption.
- Built-in DALI-2 switch can be used for standalone control or unlimited control with DALI-2 compliant control systems.



ORDERING INFORMATION

Order code	12093
Description	UMBRA PRO 1200mm Weatherproof LED Emergency batten
Driver Type	DALI DT6 LED Driver
DALI DT6 ~ Includes DALI-2 Driver with full support for DT6 allowing flicker free dimming with compliant DALI-2 Application controllers.	
Item Code	EV-UMBRA-PRO-IP65-1200-EM

EFFICIENCIES

Total System Efficiency 137 lm/W

The performance of each component of a luminaire is demonstrated through its efficiencies, which together determine the total system efficiency of the product. The output of the LED chip is first multiplied by the optical and thermal efficiencies to calculate the Luminaire efficiency. However, this calculation does not consider the driver efficiency. To determine the overall efficiency of the system, the Luminaire efficiency must be multiplied by the driver efficiency, which accounts for all losses in the system.

MECHANICAL

Body Material	Polycarbonate
Diffuser Material	Polycarbonate
Fitting Colour	Grey
IK Rating	IK08
Installation Type	Surface mount
IP Rating	IP65

ELECTRICAL

Electrical Rating	Class I
Input Frequency	50 Hz
Input voltage	230Vac
In Australia the Input voltage is defined as 230Vac -6%/+10%. This effectively means that the voltage range of these products are 216Vac - 253Vac or 240V +6%	
Maximum Wattage	33 W
Power Factor	0.95
Standby Power	0.3 W

Standby power for non-maintained/switched maintained emergency devices is measured when the light is off and the charger is in standby mode. For maintained emergency devices, standby power is measured when the light is on and the charger is in standby mode. Typically, charging occurs for the first 16 hours after the device is powered or after a battery discharge.



Switch Type Inbuilt Mains Rated DALI Switch

A Terminal input has been provided to allow the wiring of a Main rated switch input. This input can be programmed to switch any controlled area when using a DALI-2 compliant control system. This input supports IEC62386-301 (momentary or rocker switches), IEC62386-302 (on /off switches) and IEC62386-303 (mains rated sensor inputs).

System Max Wattage	30 W
Working Temp Range	0 to 40 °C

LAMP

Macadam Steps (SDCM)	3-step MacAdam Ellipse
CCT Configuration	Single
Colour Rendering Index (CRI)	>84
Lamp/LED Current	850 mA
Lamp/LED voltage	36 V

LED LIFETIME

LED Lifetime	>102000 hrs
---------------------	-------------

This is the Reported LED Lifetime in Hours based on TM-21. Ektor does not list the projected or calculated LED lifetime, which is normally longer as TM-21 Addendum B explicitly states "The Calculated and Projected Lp(Dk) are not to be reported". This Lifetime refers to the life of a single LED however the system life is longer since the probability and binomial distribution of all LEDs in the system means that the average led is performing above the specification and compensates for the LEDs falling below.

Ambient Temp (°C)	25 °C	40 °C
L90B10	55000 hrs	55000 hrs

This rating defines the performance of the led within its lifetime. L relates to lumen depreciation, where the proceeding number gives the resultant lumen output at the end of it reported lifetime. L70, would mean 30% lumen depreciation which means 70% of its initial output and is tested accordingly to TM-21. The B part refers to failures, which can be define as the percentage of LEDs which fall below the L value in the projected lifetime. A value of B10 refers to 10% failure and a value of B50 refers to 50% failure. After the defined lifetime, the system will reach the defined lumen depreciation and the average led failures is defined by the B rating. The B rating is defined in and tested to IEC62717.

TM-21 Test Hours	17000 hrs
-------------------------	-----------

COLOUR TEMPERATURE

CCT	4000 K
Luminaire Lumens	4100 lm

All photometric data has a tolerance of ±10%. Luminaire lumens refers to the exit lumens or delivered lumens from the luminaire.

DRIVER

Dimmable	Yes
Driver Included	Yes
Integrated Driver	No
Driver Mode	Constant Current
Driver Type	DALI DT6 LED Driver

DALI DT6 ~ Includes DALI-2 Driver with full support for DT6 allowing flicker free dimming with compliant DALI-2 Application controllers.

Power Monitoring	DALI Device type 51 power monitoring
-------------------------	--------------------------------------

Inbuilt DALI-2 support for Device type 51 - Power monitoring for use with DALI-2 compliant control systems which allows the reporting of the products total power consumption for power aggregation and measurements.

Wiring Type	Re-wireable terminal block (6 pin)
--------------------	------------------------------------

PSTLM	0.08
--------------	------

Short Term Light Modulation (PstLM): The requirement is that PstLM should be less than or equal to 1.0. This metric measures the short-term flicker severity and ensures that flicker is not perceptible or is at a level that does not cause discomfort or health issues.

SVM	0.018
------------	-------

Stroboscopic Visibility Measure (SVM): The requirement for SVM is that it should be less than or equal to 0.4. The SVM metric assesses the visibility of the stroboscopic effect, which can make moving objects appear to be stationary or moving in discrete steps, thus ensuring that this effect is minimized in lighting environments to prevent visual discomfort and safety hazards.

EMERGENCY (EM SUFFIX)

Replacement Battery Code	01303
Emergency Classification	C0:D100, C90:D63
Emergency Control	DALI Monitored (DT1)
DALI Monitored ~ Supports Emergency test and monitoring over DALI (IEC62386) with full compliance to IEC62386-202.	
Emergency Duration	90 mins
Emergency Lumen Output	700 lm
Emergency Mode	Maintained

COMPLIANCE

Product Design Life	12 years
----------------------------	----------

The product design life relates to the total product life which includes LEDs, drivers and the enclosure. This is different to the LED lifetime which only refers to the economical lifetime of the LEDs at which time the lumen output has dropped below the L Value. The product design life is calculated at the maximum ambient or working temperature of the product and takes into account the Daily Use.

Standards	AS/NZS 60598.1 AS 60598.2.22 AS/NZS 61347.1 AS/NZS 61347.2.13 AS CISPR 15 AS/NZS 2293.3 IEC 62386-102 IEC 62386-103
------------------	--

WARRANTY

Commercial Use Warranty	5Y return to base on General lighting components 8Y return to base on Emergency lighting components First 2Y includes an exclusive onsite warranty
VIP Warranty	2 Onsite, 3 RTB (Total 5 Years)
VIP warranty is available to registered users and is subjected to additional terms and conditions.	
Warranty Operating Hours	30000 hrs
This product is provided with a warranty up until the stated warranty period or until the stated warranty operating hours has been reached (whichever occurs first).	

DIMENSIONS

Product Height	93 mm
Product Length	1260 mm
Product Width	130 mm

LINE DRAWINGS

EV/UMBRA/PRO/IP65

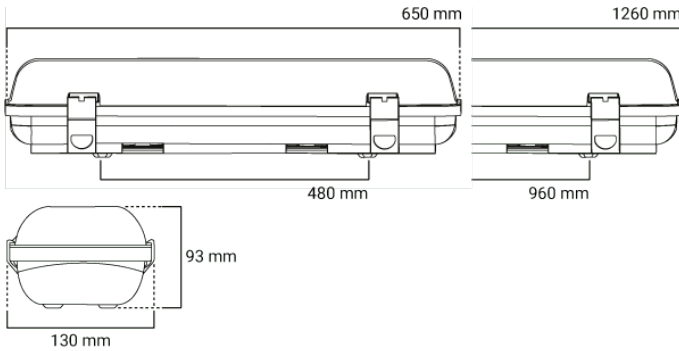

PHOTOMETRICS

EV/UMBRA/PRO/IP65/1200/EM (EM)

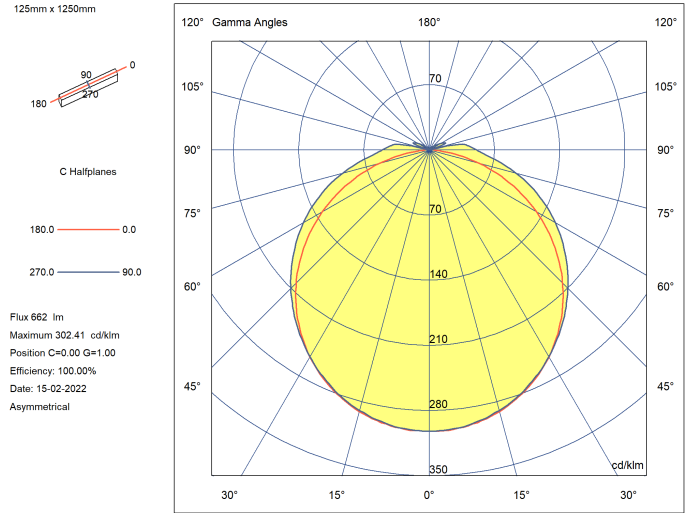

EV/UMBRA/PRO/IP65/1200 (4000K)

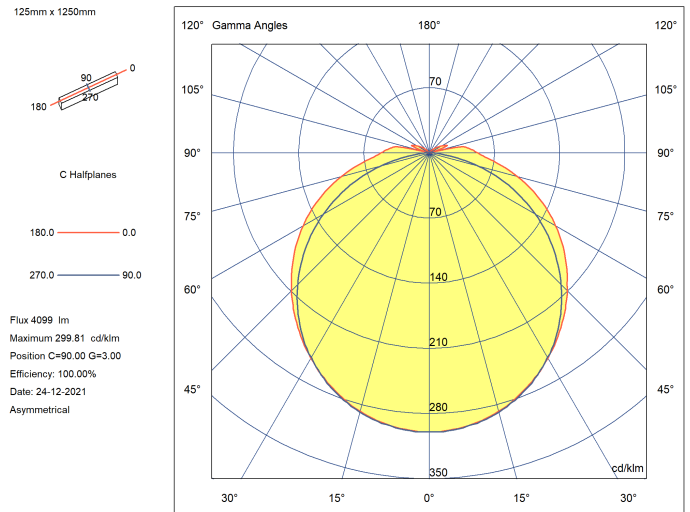

ACCESSORIES

Order code	12404
Description	Plastic Clips (10) Kit for Umbra ADV and PRO Battens
Item Code	CLIPS-AT9890-96/P
Order code	11465
Description	UMBRA Advanced and Pro vandal resist SS316 clips/screw/allen key- kit (10 pack)
Item Code	EV-SS316-WP-CLIPS