

Ewbank®

INSTRUCTION MANUAL

EW6160

AQUABLAST 160 160 Bar Pressure Washer

Ewbank has a British heritage to be proud of. It's a household favourite and much loved brand that has been providing innovative cleaning solutions for over 140 years.



CONTENTS

Safety Instructions	3-9
Appliance Overview	10
Product Assembly.....	11-13
Operating Instructions	13-18
Cleaning & Maintenance.....	19-20
Troubleshooting.....	21
Specifications	22
Fuse Replacement	23
Disposal of the Appliance.....	23
Warranty Terms & Conditions	24

SAVE THESE INSTRUCTIONS

PLEASE READ ALL THE INSTRUCTIONS BEFORE USE AND STORE THEM IN A SAFE PLACE FOR FUTURE REFERENCE. WARNINGS AND NOTES THAT ARE AFFIXED TO THE APPLIANCE PROVIDE IMPORTANT NOTES FOR SAFE OPERATION AND MUST BE FOLLOWED.

HAZARD LEVELS GUIDE

There are important notes throughout the safety instructions and instruction manual that outline potential hazards when the appliance is used. Please see below guide to these hazard levels to be aware of when reading through the instruction manual:



DANGER

This indicates an immediate danger, which if not avoided could lead to serious injury or death.



WARNING

This indicates a potentially dangerous situation, which if not avoided could lead to serious injury or death.



CAUTION

This indicates a potentially dangerous situation, which if not avoided could lead to minor injury.



ATTENTION

This indicates a potentially dangerous situation, which if not avoided could lead to damage to the appliance and/or property.

WHEN USING THE APPLIANCE, THE FOLLOWING PRECAUTIONS MUST BE TAKEN: ELECTRICAL COMPONENTS



DANGER

- Risk of electric shock.
- Never touch the mains plug and socket with wet hands.
- Check the power cord and mains plug for damage prior to every use.
- Do not use the machine if the power cord, mains plug or other important parts of the machine are damaged or appear damaged. e.g. safety devices, high pressure hoses, high-pressure gun etc.

- All electrical components within the area being cleaned must be protected against jet water.
- The mains plug and extension cable (if being used) must be watertight and must never lie in water - the use of cable reels that ensure that the sockets are at least 60mm above the ground is recommended.
- Make sure that the power cord or extension cable is not damaged by running over, pinching, dragging etc.
- Protect the power cord from heat, oil, and sharp edges or objects.
- Always switch off the power at the mains plug switch when leaving the appliance unattended.
- This pressure washer conforms to CE and other safety and consumer standards. Do not modify or rebuild any part of your pressure washer.



WARNING

- The appliance may only be connected to a mains power supply that has been installed by an electrician in accordance with IEC 60364.
- The appliance may only be connected to an alternate current and the voltage must correspond with the rating label affixed to the appliance.
- For safety reasons, we recommend that you operate the appliance only via a residual current device (max. 30mA).
- An unsuitable extension cable can be hazardous - only use an extension cable which has been approved and labeled for this purpose and has an adequate cable cross-section outdoors: 1-10m: 1.5mm²; 10-30m: 2.5mm².
- Always fully unreel the extension cable from the cable drum.

OPERATION



DANGER

- Please only operate the appliance as it is intended to be used - the operator must consider the surrounding conditions and must pay attention to other people in the area when working with the appliance.
- Check important components for damage prior to every operation such as the hose and spray gun, along with reading the safety installation instructions. Do not operate the appliance if damage is found and replace damaged components.
- The appliance has been designed for use with the cleaning substance supplied or recommended by the manufacturer - the use of the other cleaning substances or chemicals may adversely affect the safety of the appliance.
- High-pressure jets can be dangerous if subject to misuse - the jet must not be directed at persons or animals, live electrical equipment or the machine itself.
- Do not direct the jet against yourself or others to clean clothes or foot-wear.
- Do not use your pressure washer when under the influence of alcohol or drugs.

Use this power tool carefully and only when you are alert.

- Avoid contact of the pressure hose with sharp objects and examine the hose regularly. Due to the high pressure involved, it cannot be repaired if cut or damaged. Replace if damaged before use.



WARNING

- Do not use the appliance within range of persons unless they wear protective clothing.
- It is recommended to wear appropriate Personnel Protection Equipment (PPE) while operating the appliance.
- When using the pressure washer near children make sure they are closely supervised by an adult to avoid injury.
- Only use lances and accessories that are specified to withstand the water pressure of the machine.
- The appliance must not be operated by children or untrained personnel.
- This appliance is not intended for use by persons (including children) with reduced physical, sensory or mental capacities, or lacking experience and knowledge.
- Children must not play with this appliance.
- Create stability for the appliance prior to any work with the appliance to prevent accidents.
- The water jet that is emitted from the nozzle, could result in a repulsion power action on the hand spray gun - make sure that you have a firm footing and are also holding the hand spray gun and spray lance firmly.
- Never leave the appliance unattended if it is in operation.
- Always turn the water supply "on" before turning the pressure washer power "on". Running the pump dry will damage the internal components.



CAUTION

- Be aware of kick-back when using the appliance – always hold with both hands.

ATTENTION

- In case of extended breaks in usage, switch the appliance off at the main switch or pull the mains plug.
- Do not operate the appliance at temperatures below 0°C.
- Pay attention around all glass surfaces, as the jet could break a window if you are too close when pulling the trigger on the spray gun.
- Never use hot water with your pressure washer (40°C+). It will overheat and damage the pump.

OTHER RISKS**DANGER**

- The appliance must not be operated in explosive environments.
- Risk of explosion - do not spray flammable liquids.
- Never draw in fluids containing solvents or undiluted acids and solvents - this includes petrol, paint thinner and heating oil where the spray mist is highly inflammable, explosive and poisonous.
- Do not use acetone, undiluted acids and solvents, as they corrode the materials used on the appliance.
- Never use the product with inflammable, toxic liquids or liquids with characteristics incompatible with its proper operation.
- Keep packaging films away from children as there is a risk of suffocation.

**WARNING**

- According to the applicable regulations, the appliance may never be used with the drinking water network without a system separator; ensure that the connection to your house water system, with which the high-pressure cleaner is operated, is equipped with a system separator according to EN 12729 type BA.
- Water that has flowed through a system separator is no longer classified as drinkable.
- High-pressure hoses, fittings and connections are important for the safety of the appliance; only use high-pressure hoses, fittings and couplings recommended by the manufacturer.
- Only use original spare parts from the manufacturer or that are approved by the manufacturer.
- Switch the appliance off and disconnect it from the mains power supply by removing the mains plug from the socket before assembly, cleaning, adjustments, maintenance, storage and transportation.
- The improper use of detergents can cause severe injuries or oxidation.
- Store cleaning agents away from the reach of children.
- Discharge any residual pressure before disconnecting the hose from the appliance.
- Check before each use of the appliance, that all metal fasteners are tight, and the products components are in good condition; inspect for broken or worn parts.

**CAUTION**

- Check the weight of the appliance when selecting the storage location and during transport to prevent accidents or injuries.

- Several hours of continuous use of the appliance can lead to numbness in the hands in rare cases; we recommend you:
 - Wear gloves when operating the appliance.
 - Keep hands warm.
 - Take regular breaks.

RESIDUAL RISKS

Even if you are operating this product in accordance with all the safety requirements, potential risks of injury and damage remain. The following dangers can arise in connection with the structure and design of this product:

- Health defects resulting from vibration emission if the product is being used over long periods of time or not adequately managed and properly maintained.
- Danger of injury and property damage caused by flying objects.
- Injuries and damage to property due to broken accessories or the sudden impact of hidden objects during use.

SAFETY DEVICES



CAUTION

Safety devices have been installed on the appliance to provide protection to the user and may not be modified or bypassed.

- **POWER SWITCH**
 - The appliance switch prevents unintentional operation of the appliance.
- **GUN TRIGGER LOCK**
 - This locks the trigger on the gun to prevent the inadvertent starting of the appliance.
- **AUTO STOP SYSTEM**
 - If the lever on the gun trigger is released the auto stop system turns off the pump AND the high-pressure jet is stopped.
 - If the lever is pulled the pump is turned on again.
- **MOTOR PROTECTION SWITCH**
 - The motor protection switches off the device if the power consumption is too high.
- **PERSONAL PROTECTIVE EQUIPMENT**

**CAUTION**

- Wear protective clothing and safety goggles to protect against splash back containing water or dirt.
- During use the pressure washer can develop aerosols which can potentially cause health issues.
- Depending on the application, completely shielded nozzles (e.g. surface cleaner) that significantly reduce the emission of aqueous aerosols can be used for high-pressure cleaning.
- The use of such shielding is not possible with all applications.

SYMBOLS ON THE MACHINE

The high-pressure jet must not be directed at persons, animals, live electrical equipment or at the appliance itself.



The appliance must not be directly connected to the public drinking water network.



For protection against injury, wear ear defenders and safety goggles.



Wear safety gloves during use to protect hands.



Wear non-slip footwear that will protect your feet and improve your footing on slippery surfaces.

HOW TO AVOID DAMAGING SURFACES

Damage to surfaces being cleaned occurs because the impact force of the water pressure exceeds the durability of the surface. Bare wood can be penetrated; paint can be peeled off, etc. You can vary the force of your power washer by controlling:

- The angle of the water spray to the surface being cleaned.
- The distance of the nozzle from the surface being cleaned.
- Never use a narrow high-pressure stream of water from the lance on soft surfaces susceptible to damage.

PROPER USE

- Always test the surface to ensure that you do not damage it with the high pressure.
- Use this pressure washer for domestic households only.
- This high-pressure cleaner is designated with a rated input current.
- The intended use of this product covers the cleaning of vehicles, buildings, terraces, facades and garden equipment using clean water and biodegradable chemical detergents, paving slabs or rain gutters.

- This product may not be used to clean clothing, shoes and other textiles.
- The water jet should not be directed at people, animals, any electrical equipment or at the product itself.
- Do not flush any objects which contain health hazardous materials.
- The product must not be run with inflammable, explosive and toxic liquids.
- For safety reasons it is essential to read the entire instruction manual before first operation and to observe all the instructions inside.

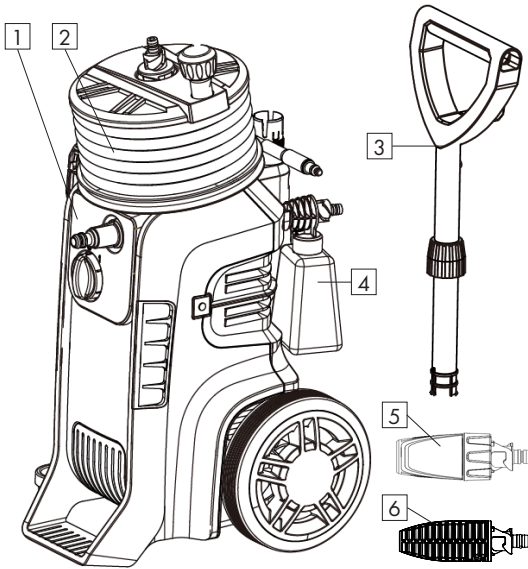

1. Pressure washer unit
2. High pressure steel hose
3. Telescopic handle
4. High pressure foam sprayer
5. Adjustable fan nozzle
6. Turbo nozzle
7. Extension lance (lance B)
8. Spray gun
9. Rotating brush*¹
10. Snow foam
11. Patio cleaner*²
12. Rim brush*²
13. Cleaning wire for nozzles

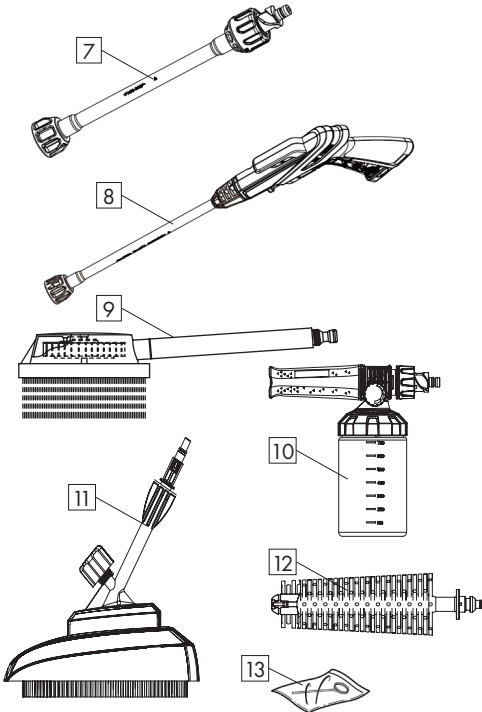

*1. Requires two adapters for use - see page 18 for instructions
 *2. Requires an adapter for use - see page 17 for instructions



CAUTION

Ensure that the appliance is fully and correctly assembled before use.

After unpacking the high pressure washer, lay out all of the parts and accessories. Familiarise yourself with the parts in the box by comparing them to those listed on APPLIANCE OVERVIEW on page 12.

Please Note: Some parts may or may not be already assembled.

Installing the washable transparent inlet filter

Take the washable transparent inlet filter from packaging and screw to front of the main unit above the "ON/OFF" switch

1. Hose reel handle (Fig.1)

- Take the hose reel handle out of the box and place in the small hole on the top of the hose reel.
- Line up with the straight edges and then push in until you hear a "click", which indicates that the handle is installed securely in place.

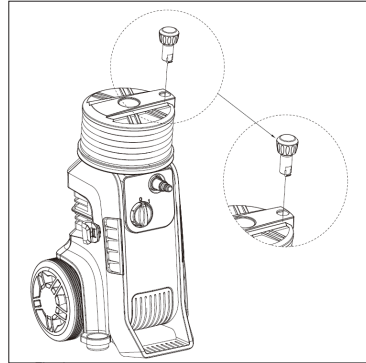

Fig.1

2. Telescopic handle (Fig.2)

Please Note: you may have to unreel a small amount of hose to fit into place.

- To fit the telescopic handle place into the top of the unit and push down to lock into place.
- To secure firmly, twist and tighten the nut.

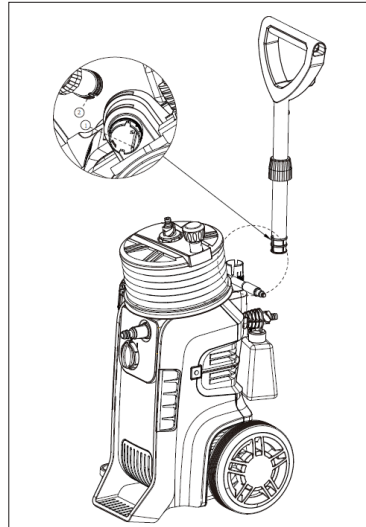

Fig.2

3. Spray gun and hose (Fig.3)

- Pull the high pressure hose from the hose reel.
- Connect by inserting the silver metal tip of the high pressure hose into the fitting under the trigger gun - it will lock into the spray gun with a "click".
- Confirm the hose is locked into the spray gun by pulling slightly on the hose.
- The hose is now securely attached to the spray gun.

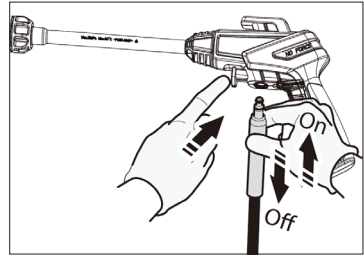

Fig.3

- To release the high pressure hose from the spray gun, press the thumb tab on the underside of the spray gun towards the trigger and the hose will slide out from the connections.

4. Spray gun and lance (Fig.4)

- While the spray gun is in the locked position, insert the extension lance into the end of the spray gun by pushing together and then twisting until it is locked in place.
- Attach the desired nozzle by inserting into the end of the extension lance before twisting and locking into place.

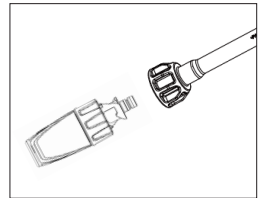
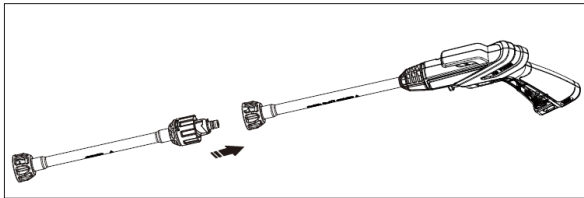

Fig.4

5. Garden hose connection (Fig.5/6/7)

- **Please Note:** The required garden hose adapter is not included with the appliance - please ensure that you have a standard garden hose adapter (Fig.5).
- Connect the garden hose adaptor (female coupler) to the water inlet of the pressure washer, then thread your garden hose (male end) into the garden hose adaptor (Fig.6 and 7).

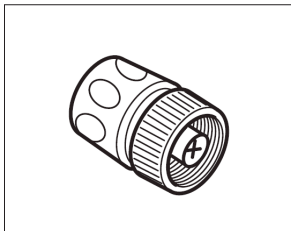

Fig.5

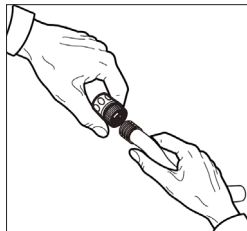

Fig.6

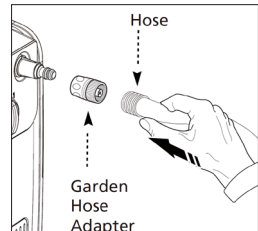

Fig.7

6. Securing the hose (Fig.8)

- Once you have wound the high pressure hose back around the hose reel, it can be locked in place by pushing the connector part into the gap between handle and hose reel.

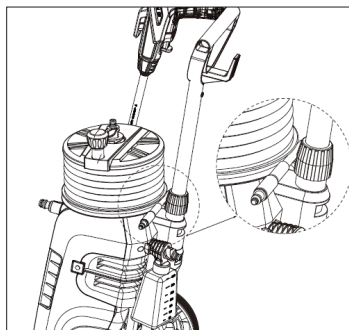

Fig.8

APPLIANCE START UP

IMPORTANT: Turn on the water supply before you start the device and the "ON/OFF" switch is in the "OFF" position (Fig.9).

- Park the appliance on an even surface.
- Insert the mains plug into the socket.

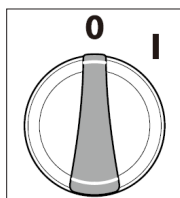

Fig.9

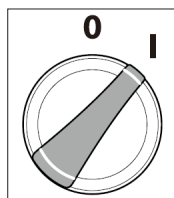

Fig.10

Water supply

For connection values, see type plate.

ATTENTION

Impurities in the water can damage the pump and the accessories.

- Attach garden hose to water supply and turn on at the tap.

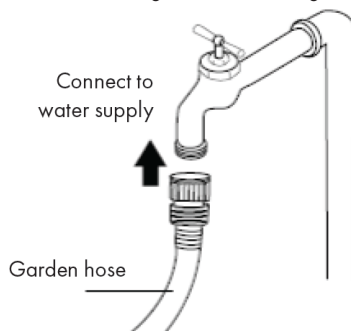

CAUTION

- o Do not connect to portable water system.
 - o The water supply must not exceed 0.7MPa.
 - o The pressure washer must only be used with clean water, use of unfiltered water containing corrosive chemicals will damage the pressure washer.
- Bleed the device as follows prior to operation:
 - Release the safety lock button on the spray gun by pushing the safety lock button from right to left.
 - While pointing the spray gun in a safe direction, squeeze the trigger on the spray gun until there is a steady stream of water, letting the water and air out of the hose.
 - Turn on the appliance by turning the "OFF/ON" switch to the "ON" position (Fig.10).
 - Squeeze the trigger on the spray gun to begin pressure washing.

ATTENTION: When not in use push the safety button back to lock the trigger.

**ATTENTION**

Dry running of more than 1 minute leads to damage of the pump. If the appliance does not build up pressure within 1 minute, switch the appliance off and proceed in accordance with the instructions in the "Troubleshooting" section of the instruction manual.

HIGH PRESSURE OPERATION**CAUTION**

Keep a distance of at least 30cm when using the jet for cleaning painted surfaces to avoid damage.

CAUTION

Make sure the power switch is set to "OFF" before inserting the plug into a properly installed socket.

**ATTENTION**

- The washer must be used on a secure and stable surface.
- Connect the product to power and water supply as described.
- Open the water supply.
- Hold the gun with both hands.
- Direct the nozzle of the chosen accessory away from you towards the surface to be cleaned.
- Unlock the trigger and press it until a constant amount of water flows through the nozzle, to allow air trapped in the hose to escape.
- Release the trigger.
- Turn the power switch from "OFF" to "ON".
- Hold the spray gun with both hands. Direct the water jet to the object to be cleaned and squeeze the trigger.
- Release the lever of the gun; the device will switch off again and stop the water jet.

Please Note: High pressure remains in the system.

**ATTENTION**

- If you hear the motor running while the trigger is not being squeezed, this is normal. The pump is priming itself so it is ready to operate when the trigger is squeezed.
- Turn off the power washer if not being used after five minutes.
- Do not pull/release the trigger rapidly multiple times as this will cause the Total Start Stop system (TSS) to malfunction and the unit will not turn on. Pull trigger methodically.



WARNING! Beware of kickback when pressing the trigger!

SPRAY GUN OPERATION

- To lock the trigger of the spray gun, make sure power is off (0).
- Aim the spray gun away from you and push the lock button up (Fig. 11).
- After doing so, squeeze or pull the trigger to make sure it is locked and will not move.

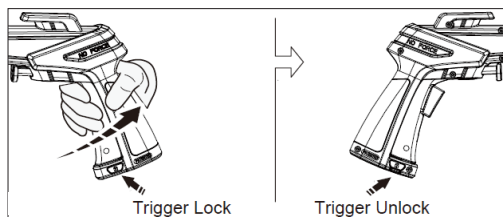

Fig.11

'No Force' trigger operation:

- Squeeze the trigger fully in until you hear the click.
- Once you hear the click you can operate by lightly pushing in the black part of the 'No Force' trigger.

OPERATION WITH ATTACHMENTS



ATTENTION

- Your AQUABLAST160 comes with certain accessories - only use original accessories and original spare parts for this model as this will ensure that the appliance runs fault-free and safely.
- All brushes need to be used with the adapter provided - with the adapter in place at the end of extension lance B, insert the brush by pushing then twisting until it locks into place.
- When using nozzles always test on a small area first.

ASSEMBLING PATIO CLEANER

Thread the patio cleaner connector into the larger hole on top of the cleaner head. On the underside push the rotating spray arm in and screw into place (Fig.12).



Fig.12

ATTACHMENT APPLICATIONS

Adjustable spray nozzle: Great for general washing with variable spray ranging from fan spray to jet power spray.

Turbo nozzle: Use for removing tough areas of dirt with a concentrated jet spray.

Patio Cleaner: Great for cleaning patios, decking and pathways.

Rim Brush: Ideal for cleaning wheel arches rims and alloys. Also underneath of garden furniture and hard to reach areas.

Rotating brush: For car body, the constant rotation of the brush saves pressure by the operator and prevents scratching paint work.

Please Note:

- Rotation brush needs to be use with an additional adapter.
- It is best to apply this adapter to the rotation brush first before connecting.
- Push down hard and screw until tight.
- With the adapter place insert at the end of the other adapter already connected extension lance B.

DETERGENT OPERATION

- When using detergent, attach the high pressure foam sprayer (Fig.13) directly onto the end of the extension lance until it "clicks" and turn to lock in place.
- When using the detergent bottle, fill it with a properly formulated detergent or cleaner with a water ratio according to instructions on the container (Fig.14).
- The detergent bottle comes with a straw which is fitted into the screw-on top. If you do not see the straw, look inside the bottle and attach it to the screw-on top.

SNOW FOAM: This attachment creates a thick layer of cleaning foam that stays on surfaces longer and increases the chemical/soap action time to provide a deeper clean than standard foam sprayers - ideal for getting the perfect finish when washing the car.

Please Note:

- When using detergent, attach the high pressure snow foam bottle/nozzle directly onto the end of the lance (B) until it "clicks" and turn to lock in place then screw red part tight to secure.
- When using the snow foam bottle, fill it with a properly formulated detergent or cleaner (designed for pressure washers) with a water ratio according to instructions on the detergent container.
- When in operation the snow foam detergent nozzle can be changed for desired effect.
- Twist the black end of the nozzle.
- Turn clockwise to decrease the foam and anti-clockwise to increase the foam.
- Turn the red dial on the side of the snow foam head this increases or decreases the amount of detergent used. Indicator on the dial with show the flow amount.

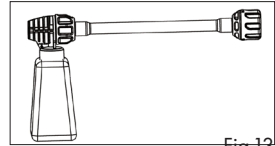

Fig.13

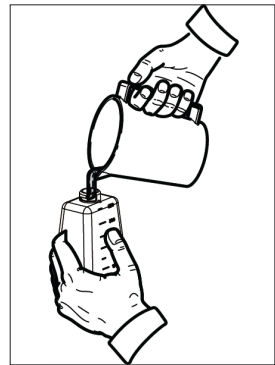

Fig.14

**ATTENTION**

The O-rings on the bayonet end of the lance and detergent bottle should be cleaned regularly and lubricated with light grease or petroleum jelly.
Only use detergents designed for use with pressure washers.

ENDING OPERATION**CAUTION****Releasing pressure in the system**

Injuries can occur from high-pressure water escaping.

- Only disconnect the hose from the gun or the device when the system is fully depressurised.
- Release the lever of the gun.
- Turn the power switch to "OFF".
- Disconnect the mains plug from the socket.
- Only separate the hose from the gun or the device when there is no pressure in the system.

TURN OFF TAP

- Press the lever of the gun to release any remaining pressure in the system.
- Release the lever of the gun.
- Lock the lever of the gun.

**ATTENTION**

- When disconnecting the supply or hose, warm water may leak from the connection after operation.
- Detach the appliance from the water supply.

TRANSPORTATION**CAUTION**

- Risk of personal injury or damage!
- Mind the weight of the appliance during transport.

Transporting by hand

- Switch the product off and disconnect it from the water and mains power supply.
- Pull out the transport handle until it audibly clicks into place. Attach transportation guards, if applicable.
- Pull the appliance by its transport handle.

Transporting in vehicles

- Prior to horizontal transport: close the cap of clean detergent bottle.
- Tilt the product towards you until it balances on the wheels. Then move it by its transportation handle.
- Protect the product from any heavy impact or strong vibrations which may occur during transportation in vehicles.
- Secure the appliance against shifting and tipping over.

STORAGE



CAUTION

- Risk of personal injury or damage!
- Consider the weight of the appliance when storing it.

STORING THE APPLIANCE

- Park the machine on an even surface.
- Detach spray lance from the gun.
- Push the disconnect button on the gun and pull the hose out of the gun.
- Place the spray gun into the storage part on the handle hook.
- Put spray lance into the storage compartment on the side of the main body.
- Wind the hose back onto the hose reel and lock the hose reel by pushing the connector part into the gap between handle and hose reel.
- Store the mains power cord on hook on the handle - it is recommended that this is done before storing the spray gun on the same hook.
- The foam sprayer bottle can be stored on the back of the main unit on 'U' clip.
- A nozzle can be stored in the top of the hose reel in the large hole.
- Prior to extended storage periods (such as during winter months) also observe the instructions in the care section.
- Always store the pressure cleaner, parts, and accessories in a place that is inaccessible to children.
- The ideal storage temperature is between 10°C and 30°C.
- Store the power washer indoors to prevent the water in the unit from expanding under freezing conditions.
- We recommend using the original package for storage or covering the product with a suitable cloth or enclosure to protect it against dust.

FROST PROTECTION



ATTENTION

Appliance and accessories that are not completely drained can be destroyed by frost. Completely drain appliance and accessories and protect them against frost. To avoid damage:

- Detach the appliance from the water supply.
- Detach spray lance from the gun.
- Turn on the appliance "ON/OFF".
- Push the lever of the gun until no more water is escaping.
- Release the lever of the gun.
- Lock the lever of the gun.
- Turn off the appliance.
- Store the appliance and the entire accessories in a frost-free room.

CARE AND MAINTENANCE



DANGER

Risk of electric shock.

Prior to all work on the appliance, switch off the appliance and pull the power plug.

High pressure hose

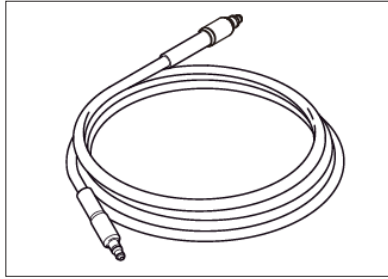

Fig.15

The hose (Fig.15) is specially constructed with reinforced walls. It can be easily damaged and should be stored carefully.

- Do not kink.
- Do not drive vehicles over the hose.
- Do not expose the hose to sharp edges or corners. Misuse will lead to ballooning or premature failure and will invalidate warranty.

Nozzle

- Disconnect the nozzle from the spray wand once the cleaning job is complete.
- Do not expose the nozzle in corrosive liquid.

Filter in the water connection



ATTENTION

- The filter must not be damaged.
- Pull the filter out using flat pliers.
- Clean the filter under running water.
- Reinsert the filter into the water connection.

Clean the filter in the water connection regularly.

- Remove coupling from the water connection, and rinse with warm water to prevent any foreign matter from clogging the pump.
- Clean the nozzle with the needle clean-out tool provided (Fig.16).

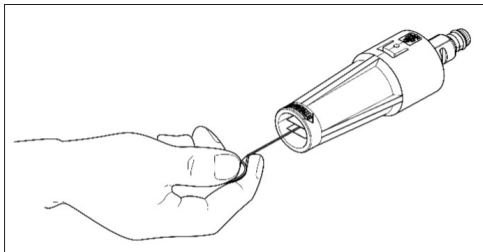

Fig.16

- Remove the extension lance from the spray gun.
- Remove any dirt from the nozzle and rinse.



ATTENTION

A clogged or partially clogged nozzle can cause significant reduction of water pressure coming out of the nozzle and/or cause the unit to pulsate while spraying.

DO NOT store the pressure washer or its accessories where it is exposed to freezing temperatures.

If you experience difficulties with the appliance, please check the suggestions below before contacting customer services on 01473 271272:

Problem	Cause	Possible Solution
Machine doesn't start	Machine not plugged in	Plug in machine
	Defective socket	Try another socket
	Fuse has blown	Replace fuse. Switch off other machines
	Defective extension cord	Try without the extension cord
Fluctuating pressure	Pump sucking air	Check that hoses and connections are airtight.
	Valves dirty, worn out or stuck	Clean and replace or refer to local distributor
	Pump seals worn out	Clean and replace or refer to local distributor
Machine stops	Incorrect mains voltage	Check that the mains voltage corresponds to specification on the model tag
	Thermal sensor activated	Leave the washer for 5 minutes to cool down
	Nozzle partially blocked	Clean the nozzle
Machine pulsating	Air in inlet hose	Allow machine to run with open trigger until regular working pressure resumes
	Inadequate supply of mains water	Check that the water supply corresponds to specifications required NOTE: Avoid using long, thin hoses (min. 1/2")
	Nozzle partially blocked	Clean the nozzle
	Water filter blocked	Clean the filter
	Hose kinked	Straighten out hose
Machine starts, but no water comes out	Pump/hoses or accessory frozen	Wait for pump/hoses or accessory to thaw
	No water supply	Connect inlet water.
	Water filter blocked	Clean the filter
	Nozzle blocked	Clean the nozzle
The high pressure hose will not connect / stay connected to the spray gun	The rubber sleeve covering slipped towards metal tip	Pull the rubber sleeve down until the entire metal tip is visible
Water leaking where the high pressure hose connects	Seals and valves are dirty or worn	Clean and/or replace seals and/or valves

SPECIFICATION

Model:	EW6160 AQUABLAST160
Voltage:	230V
Frequency:	50Hz
Power (W):	2200
Protection Class:	I
IP Rating:	IPX5
Maximum Pressure (Bar):	160
Maximum flow rate (L/hrs):	468
Noise Level (dB):	95
Pump type:	SF01 /Aluminium
Auto-stop system:	Yes
Self-priming:	Yes
Hose material:	Steel
Product dimensions (mm):	H:770 x W:325 x D:310
Product weight:	9.5kg

Fuse Replacement (Class I)

Remove the fuse cover with a small flat head screw driver. Take out the fuse and replace with a new fuse of the same Amp. Replace the fuse cover and push back into place.

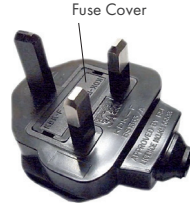

Disposal Information

The European Directive 2012/19/EU on Waste Electrical and Electronic Equipment (WEEE), requires that old household electrical appliances must not be disposed of in normal unsorted municipal waste.

Old appliances must be collected separately in order to optimise the recovery and recycling of the materials they contain and reduce the impact on human health and the environment.

The crossed out “wheeled bin” symbol on the product reminds you of your obligation, that when you dispose of the appliance it must be separately collected. Consumers should contact their local authority or retailer for information concerning the correct disposal of their old appliance.





Ewbank Warranty Terms & Conditions

This product is guaranteed for a period of 24 months as standard from the date of purchase against mechanical and electrical defects.

To qualify for the warranty, the product must be used for domestic household use only and in accordance with the instructions in the user manual. Any misuse of the product will result in the warranty being void.

The warranty does not cover accidental damage, misuse, neglect, tampering or incorrect adjustment or installation.

The warranty will be rendered invalid if the product is resold, has had its serial number removed (or has an invalid serial number), or if an unauthorised person has carried out any repairs or alterations.

The warranty does not cover accessories or consumable parts that require replacement under normal use. This includes shelving, dials, filters, belts and trays etc.

In the unlikely event of a breakdown please refer to the Troubleshooting guide in your user manual and check all plugs, fuses and the mains power supply.

If you still require assistance please contact our Customer Service department on **01473 271 272** or write to us at the following address:

**Customer Service Department
Ewbank, 38 Bluestem Road,
Ipswich, Suffolk, IP3 9RR**

Please quote the Product Code and the PO Number on the rating label and give details of the exact fault. We will then decide whether to repair or replace the item.

Before we arrange the repair or replacement you will be required to return a copy of your proof of purchase. Please retain your original.

If an item is replaced within the agreed warranty period, the warranty for the replacement item will be calculated from the purchase date of the original.

In the event that the product is inspected and no fault is found or the product is not within the warranty period you will be charged for the repair and any carriage costs.

Ewbank[®]

Your Guarantee

This product is covered by a 2 year guarantee.

This does not cover normal wear and tear or abuse.

For guarantee purposes, please retain your original receipt as proof of purchase.

This guarantee does not affect your statutory rights.

For spares, service and further information please contact;

UK: Ewbank, 38 Bluestem Road, Ipswich, Suffolk, IP3 9RR

EU: Castle Electrical Factors Ltd., Dundalk, A91 KA9R, IR

Tel: 01473 271 272

Disclaimer: Ewbank operate a policy of continual improvement and development.

We therefore reserve the right to change/alter the specification and appearance of our appliances without prior notice.

All diagrams and images shown in this manual are for illustration purposes only.