

24 Hour Socket Box Mechanical Timer

Product Ref: **F4P24/SKT**

Technical Features:

- Ideal for heating, lighting and security applications
- Traditional looking analogue clock face
- 24 hour mechanical control timer
- 96 on/off operations per day
- Minimum switching time: 15 minutes
- 16A resistive load; 2A inductive loads
- Selector switch: On/Auto/Off
- Red power indicator light
- Fits easily to any back box as shallow as 35mm
- Easy grip centre to make clock adjustment
- Manual override facility

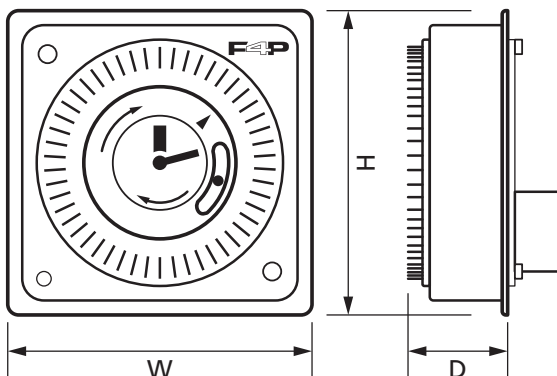

Product Specification

Colour	White
Compliance	UKCA, CE
Current Rating	16A
Display Type	Analogue
Frequency	50Hz
Guarantee	1 Year
Material	Plastic
Minimum Time Settings	15min
Mounting	Socket Box
Neon	Yes
Number of On/Offs	96
Override Switch	Yes
Programming Type	Segmented
Standards	EN 60730-1, EN 60730-2-7
Voltage Rating	230V
Weight	0.128kg
Depth	38mm
Height	86mm
Width	86mm

Errors and omissions excepted (E&OE). All information is subject to change without notice and is correct at the time of print. Refer to issue number and date below.

Tel: +44 (0)1302 765 570 • f4p-products.com • [X@F4Pinfo](mailto:info@f4pinfo.com)