

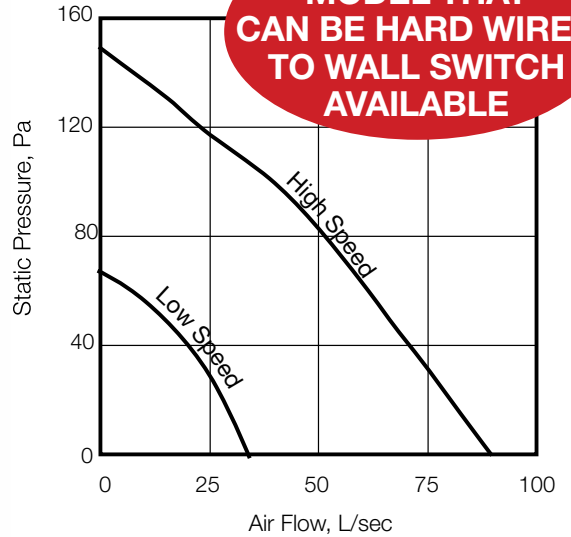

WIRELESS (RF) WALL MOUNTED CONTROLLER

NEW MODEL THAT CAN BE HARD WIRED TO WALL SWITCH AVAILABLE



RESPONSE RADIANCE

3 IN 1 BATHROOM HEATER, EXHAUST FAN & LIGHT

5* YEAR WARRANTY	RAPID INSTALL	POWERFUL AIR FLOW	IPX4	BUILT TOUGH FROM ABS	BUILT-IN CCT LED LIGHT
----------------------------	-------------------------	-----------------------------	-------------	--------------------------------	-------------------------------

The Response Radiance with heater, exhaust fan and light sets a new benchmark for 3 in 1 bathroom units. Its modern and sleek design will seamlessly complement any bathroom or ensuite style. It has been engineered to efficiently exhaust steam and odours, deliver instant heat, and provide effective lighting within the room. Its unique design, lightweight construction and full function wireless wall controller, make the Response Radiance super easy to install into established or new homes.

- Designed and engineered for fast and efficient installation.
- Modern contemporary design.
- Wireless wall controller activates all operating functions.
- Tungsten-Halogen heat lamps provide instant heating.
- LED lights can be set to warm white, cool white or daylight to match other installed lights.
- High and low heat selection.
- 2 speed fan operation.
- Equipped with non-return backdraft damper.
- Made from ABS for a tough but light-weight design.
- Fitted with plug and lead.
- Grille can be easily removed for cleaning.

FAN DIMENSIONS

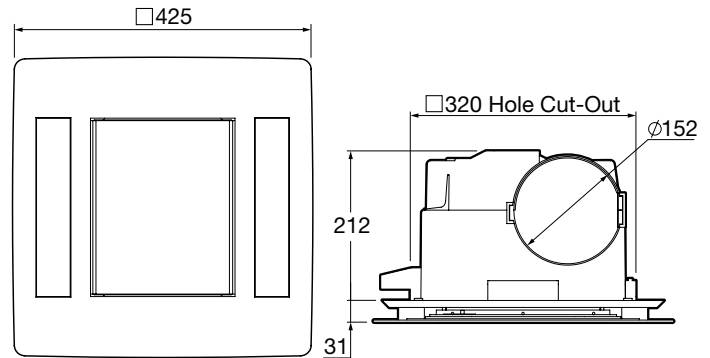

CONTROLLER DIMENSIONS

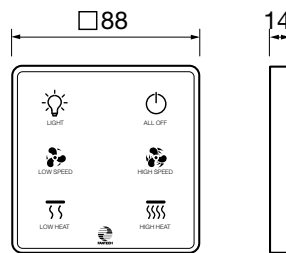

All dimensions in mm

HARD WIRED MODEL

- Can be hard wired to a standard 5 gang wall switch.
- Includes a 10 minute run-on timer, which makes it compliant with NCC 2022.**

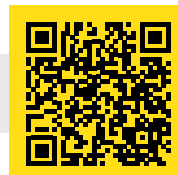

Scan the QR code to see fan features.

*Conditions apply. 1 year warranty on the Tungsten-Halogen heat lamps. For details visit: fantechtrade.com.au/warranty

**Complies with requirements of NCC 2022 Vol 1 Part F8D4 and ABCB Housing Provision Part 10.8.2, when correctly installed. 5 gang wall switch not included.



Quality AC motor with sealed for life bearings

Advanced impeller and housing design

Grille is easy to remove for cleaning



Removable 1 piece spigot

Non-return backdraft damper

High strength installation swing clips

SPECIFICATIONS

Model		RESP3-1WH	RESP3IN1WH
CONTROL		Wireless (Rf) Wall Mounted Controller (Included)	Hard wired 5 gang switch (not included) and/or wireless (RF) Wall Mounted Controller (Included)
RUN-ON TIMER		N/A	10 minute
AIR FLOW M³/HR**	HIGH SPEED	313	313
	LOW SPEED	108	108
AIR FLOW L/SEC**	HIGH SPEED	87	87
	LOW SPEED	30	30
NOISE LEVEL DBA @ 3M	HIGH SPEED	37	37
	LOW SPEED	27	27
FAN POWER		40W	40W
LIGHT POWER		24W	24W
HEATER POWER		2 x 500W	2 x 500W
VOLTAGE		230-240V	230-240V
HERTZ		50	50
LIGHT LUMENS		1560Lm [†]	1560Lm [†]
LIGHT COLOUR TEMPERATURE		3000K/4200K/6000K	3000K/4200K/6000K
IP RATING		IPX4	IPX4

** Air flow with Response Radiance internal grille attached and without ducting or additional fittings.
[†] On 4200K light colour temperature.

ENGINEERED TO COMPLIMENT ROOM SHAPE

Grille can be rotated 90 degrees so the alignment of LED lights and heat lamps can better suit shape of the room. This enables spigot and ducting to remain parallel to ceiling joists and avoid kinks or sharp bends in duct.

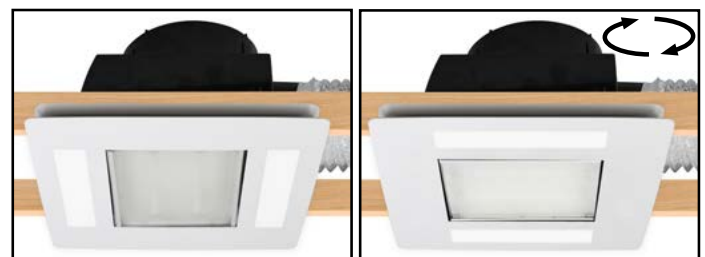

REPLACEMENT PARTS

MODEL NO.	DESCRIPTION
RESP3HEATLAMP	Tungsten-Hologen Heat Lamps
RESP3GLASS	Glass
RESP3REMOTE	Wireless Wall Mounted Controller
RESP3-1GRILLE	Grille with LED Lights

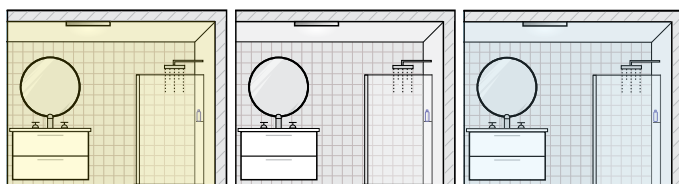

Warm White

(Colour Temperature: 3000K)

Cool White

(Colour Temperature: 4200K)

Daylight

(Colour Temperature: 6000K)

Colour indicated in drawings above is for illustrative purposes only.