

Electromagnetic Fire Door Holders

WALL MOUNTED DOOR RETAINERS

FMH/M24N & FMH/M230N Door Retainer **FMH/MFBN** Floor Bracket



FMH/MFBN Floor Bracket

With a flame retardant, low profile ABS plastic body or a robust steel facia plate version available as a special order item

Installation is, with knockouts provided for entry of surface mount conduit, there is ample space to connect external wiring to the 4.0mm terminals.

Each door retainer is fitted with a spring loaded release pin mounted centrally within the electro-magnet. On power off, the release pin then ensures that the fire door is pushed away from the electro-magnet.

Additional accessory products are available, including floor brackets, chains and additional keeper plates.

All door retainers are designed to comply to the latest requirements of EN 61000-3-2, EN 50081-1, EN 60950 and EN 1155.

TECHNICAL INFORMATION

Supply Voltage and Tolerance	24V DC \pm 10%	230V AC \pm 10%	
Current Consumption	50mA	12mA	
Rated Holding Force	450N	200N	
Maximum Holding Force	750N	250N	
Residual Holding		ZERO	
Release Switch		YES	
Protection		IP51	
Keeper Adjustment		\pm 30 °	
Weight (per unit packed)	500g	400g	400g
Material		ABS	
Door Closer, Power Size		3 - 6	

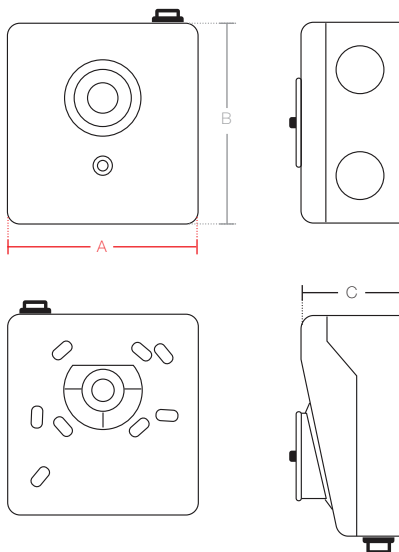

FMH/M24N Dimensions:
 A: 87mm B: 95mm C: 46mm