

5W LED GU10

Product Ref: **EDLED/GU10/5CW**

Technical Features:

- Low power consumption
- Long lamp life
- Low surface temperature
- Up to 90% energy savings
- No UV output
- Equivalent replacement for a 50W halogen lamp
- Ideal for accent and general lighting (i.e. hotels, shops, offices etc)

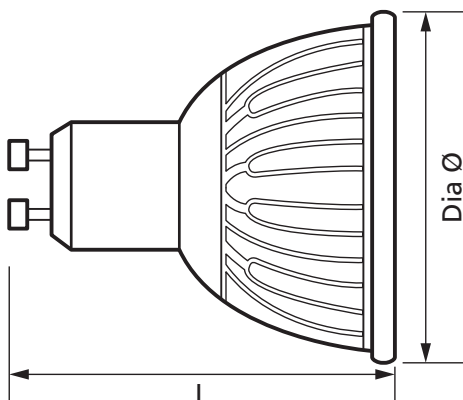

Product Specification

Beam Angle	38°
Cap Type	GU10
Colour Temperature	4000K
Compliance	UKCA, CE
CRI	80
Dimmable	No
Energy Rating	F
Guarantee	3 Years
Finish	Silver
Lamp Life (L70/B50)	25000 hours
Lamp Type	LED GU10
Lens Colour	Clear
Lumens	510lm
Lumens (Useful) 90°	400lm
Mercury Content	0mg
Suitable For	Ideal for Accent and General Lighting
Switching Cycles	100000
Voltage Rating	230V
Wattage	5W
Weight	0.043kg
Diameter Ø	50mm
Length	56mm

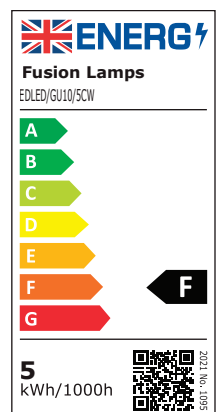
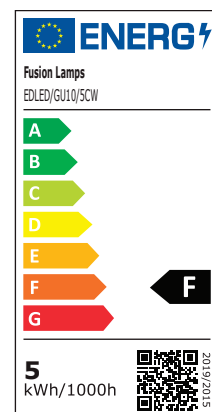

Errors and omissions excepted (E&OE). All information is subject to change without notice and is correct at the time of print. Refer to issue number and date below.

Tel: +44 (0)1302 822 833 • fusion-lamps.co.uk