

BATTEN

30W 5ft LED Emergency Batten & Sensor CCT

Product Ref: **FBAT5CCSE3**

Technical Features:

- New modern design
- Polycarbonate UV stabilised diffuser
- Steel body with powder coated finish
- CCT colour select function (WW/CW/DW)
- Quick release access system
- Supplied with safety cords to LED tray
- Push-fit (loop-in/loop-out) terminal blocks
- Maintained emergency (3hr/180mins)
- Built-in microwave sensor

Product Specification

Beam Angle	120°
CCT	3000K Warm White / 4000K Cool White / 6500K Daylight White
Class	Class 1
Colour	White
Compliance	UKCA, CE
CRI	>80
Emergency	3 Hours - Maintained
Finish	Powder Coated
Fixing Centres	1056mm
Frequency	50-60Hz
Guarantee	2 Years
IP Rating	IP20
IK Rating	IK06
Lamp Life (L70/B50)	50000 hours
Lens Colour	Opal
Lumens	3600lm
Material	Steel Body / Polycarbonate Diffuser
Mounting	Surface/Suspended
Operating Temperature	-20 - +40°C
Sensor	Microwave
Voltage Rating	230V
Wattage	30W
Weight	2.400kg
Depth	72.5mm
Length	1500mm
Width	72mm

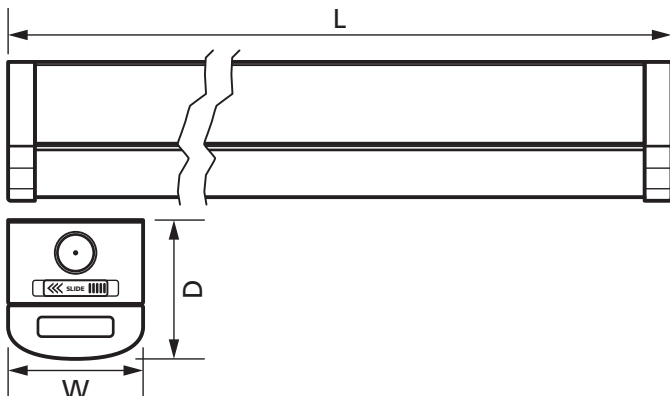

Errors and omissions excepted (E&OE). All information is subject to change without notice and is correct at the time of print. Refer to issue number and date below.

Tel: +44 (0)1302 769 966