

The logo for HEATSTORE, featuring the word "HEATSTORE" in a bold, sans-serif font. The "HEAT" part is in red and the "STORE" part is in grey. To the left of the text is a red icon consisting of three horizontal bars of varying lengths, resembling a stylized flame or heat source.

THE TOTAL ELECTRIC HEATING SOLUTION

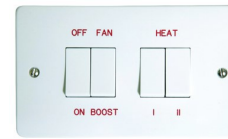

Commercial Air Curtains

Installation and Operating Manual

HSAC9000E, HSAC12000E, HSACW9000E, HSACW12000E,
HSACW14000E, HSACW15000E, HSACW18000E

All electrical appliances produced by the company are guaranteed for two years against faulty materials or workmanship. This applies only if the appliance has been used for purposes in accordance with the instructions provided and has not been connected to an unsuitable electricity supply, or subject to misuse, neglect, damage or modified or repaired by any person not authorised by us. This guarantee is offered to you as an extra benefit and does not affect your legal rights.

The correct electricity supply voltage is shown on the rating label attached to the appliance.

Reasonable care has been taken to ensure that this guide is accurate at the time of printing. In the interest of progress the company reserve the right to vary specifications from time to time without notice.

Contents

1 General Information

- 1.1 Warnings
- 1.2 Health and Safety
- 1.3 Electrical Supply
- 1.4 Location
- 1.5 Clearance Distance
- 1.6 Standards

2 Introduction

- 2.1 Introduction
- 2.2 Mechanical switch
- 2.3 Touchscreen controller

3 Dimensions & fixing locations

- 3.1 Dimensions
- 3.2 Fixing location

4 Technical Specification

- 4.1 Specification

5 Wiring Details

- 5.1 Installer Wiring
- 5.2 Factory Wiring
- 5.3 Network Wiring - Controller
- 5.4 Network Wiring - Switches

6 Modifying the heater to single phase operation

7 Installation Details

- 8.1 Screw location for grille removal
- 8.2 Mounting
- 8.3 Electrical Supply
- 8.4 Installation

8 Fault detection and LEDs

- 8.1 Installer Wiring
- 8.2 Overheat protection reset

9 BMS Connection MODBUS Protocol

- 10.1 BMS Connection
- 10.2 MODBUS Protocol

10 Touchscreen Controller Operation

- 11.1 Main Screen
- 11.2 Setting menu
- 11.3 Time
- 11.4 Lock
- 11.5 Timer
- 11.6 Timer - time schedule
- 11.7 External switches
- 11.8 Operating Mode selection
- 11.9 Manual Mode
- 11.10 Automatic Mode
- 11.11 Temperature Mode 1
- 11.12 Temperature Mode 2
- 11.13 Energy usage
- 11.14 Identification

1. General Information

1.1 Warnings

All installations must be in accordance with the regulations. These instructions must be handed to the user on completion of the installation. Installers and service engineers must be able to demonstrate competence and be suitably qualified in accordance with the regulations. To ensure continued and safe operation it is recommended that the appliance is serviced annually. The air curtain outlet/inlet grille must not be obstructed during use. Any modifications made to the unit not approved by Heatstore will void manufacturers warranty and potentially create a hazard. The appliance is NOT intended for use by persons (including children) with reduced physical, sensory or mental capabilities or lack of experience or knowledge unless they have been given instruction concerning use of the appliance by a person responsible for their safety. Children should be supervised to ensure that they do not play with the appliance. Parts of the heater can become very hot when in operation and cause burns. The heater is not equipped with a room thermostat and should not be used in small rooms so as to avoid overheating.

1.2 Health and Safety

Please read this instructions thoroughly before installing the appliance. Sole liability rests with the installer to ensure that all site safety procedures are adhered to during installation. Sole liability rests with the installer to ensure that protective safety wear such as hand, eye, ear and head protection is used during installation of the product. Ensure that all anchoring points are suitable for the weight of the appliance.

1.3 Electrical Supply

This heater must be permanently connected to the electricity supply via an isolated switch. It must provide all-pole disconnection and have a 3mm gap on each pole.

There are no exceptions.

All units must be wired in accordance with I.E.E. regulations for the Electrical Equipment of Buildings.

BMS control, time switches and door interlocks can be installed at the discretion and responsibility of the installer.

Follow paragraph 4 'technical specification' for more details.

1.4 Location

All units should be installed directly over the door opening. It is recommended that the air curtain is installed on the inside of the building.

Care must be taken to allow complete free air movement into the inlet grilles of the unit to ensure correct working operation of the air curtain. The discharge opening should be as close to the top of the door as possible and cover the entire door width.

Units can be mounted adjacent to each other to cover the full door opening across wider entrances.

1.5 Clearance Distance

It is recommended that a minimum clearance of 50mm is allowed above the heater. The clearance allows for cable entry and additional air inlet. It also prevents surfaces overheating.

The minimum mounting height (floor to grille) is 2m. The maximum mounting height is 3.4m.

1.6 Standards

The heater conforms to the following standards
Electrical Equipment (Safety) Regulations 2016
SI. 2016 1101

Electromagnetic Compatibility Regulations
2016 SI. 2016 No. 1091

Radio Equipment Regulations 2017 SI. 2017
No. 1206

The Ecodesign for Energy Related Products
and Energy Information (Amendment) (EU Exit)
Regulations 2019. SI. 2010 2617

The Restriction of use of Certain Hazardous
Substances. SI. 2012 No. 3032

The Supply of Machinery (Safety) Regulations
2008 (SI 2008/1597)

2. Introduction

2.1 Introduction

This instruction manual describes the Heatstore Commercial range of air curtains. They are designed for discreet positioning above the doorways of retail or commercial premises up to 3.4m ceiling height.

The air curtains comprise multiple modular blower units 510mm or 615mm wide and with nominal maximum power output from 4.5kW to 7kW 3Ph 415V.

Models are available in 1.3m, 1.5m and 1.97m lengths, made up of 2 or 3 blower units. For wider doorways, up to 7 air curtains can be easily interconnected using CAT5/ CAT6 RJ45 networking cable.

It is recommended that this control cable is run separately within its own trunking to avoid external interference.

The air curtain can be controlled by optional HSACMC controller (not supplied with the heater), mechanical switch (supplied), or BMS.



WARNING:

THIS AIR CURTAIN SHOULD NOT BE INSTALLED WHERE THERE IS A **CORROSIVE ATMOSPHERE OR EXCESSIVE DUST.**

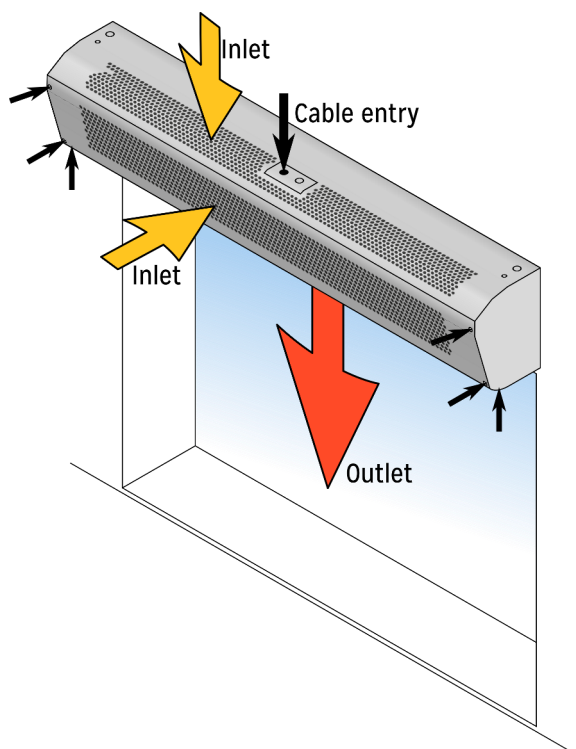

2.2 Mechanical switch Controller

Each air curtain is supplied with HSRCU2 mechanical switch. More details at Installer wiring section. This controller will provide 2 fan speed and 2 heat setting options.

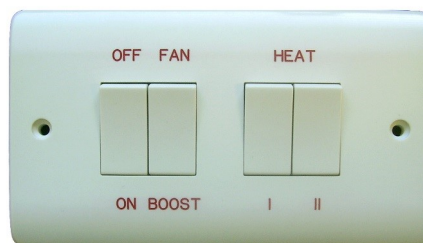

2.3 Optional HSACMC Touchscreen Controller

Optional HSACMC touch screen controller (not supplied with the heater) giving options for 8 fan and 8 heat settings can be mounted up to 50m from the air curtain. Optional BMS control, remote thermostats and door interlocks can be installed.

The electronic touch screen controller shown on the picture below allows the user to control either a single air curtain, or a network of up to 7 air curtains with the same settings.

The controller is designed to be mounted on a surface double gang back box, and is powered by an RJ45 connection. **The controller will not fit metal or dry lining back box.**

The cable length between the base unit and the controller can be up to 50 metres.



3. Dimensions & Fixing locations

3.1 Air Curtain Dimensions

Dimensions: Length x Height x Depth:

HSAC9000E, 12000E - 1301 x 264 x 200mm

HSACW9000E, 12000E, 14000E - 1520 x 264 x 200mm

HSACW15000E, 18000E - 1952 x 264 x 200mm

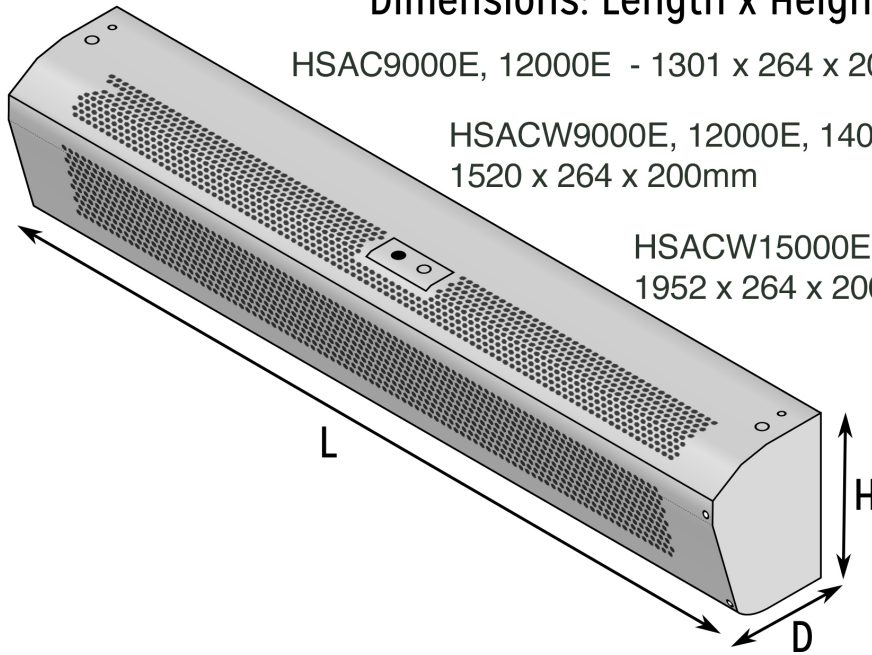

3.2 Fixing Locations

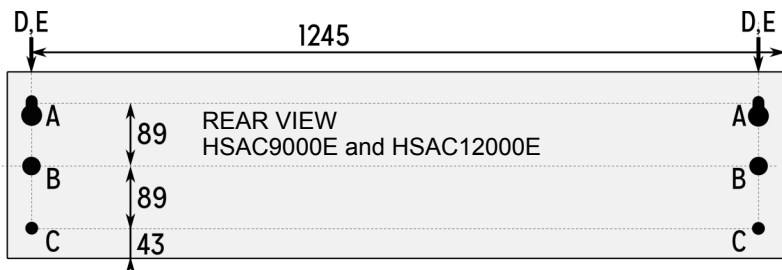

- A: Keyholes for Ø6mm fixings
- B: Holes for Ø10mm fixings
- C: Holes for Ø6mm fixings
- D: Ø20mm knock-outs
- E: M8 threaded fixings

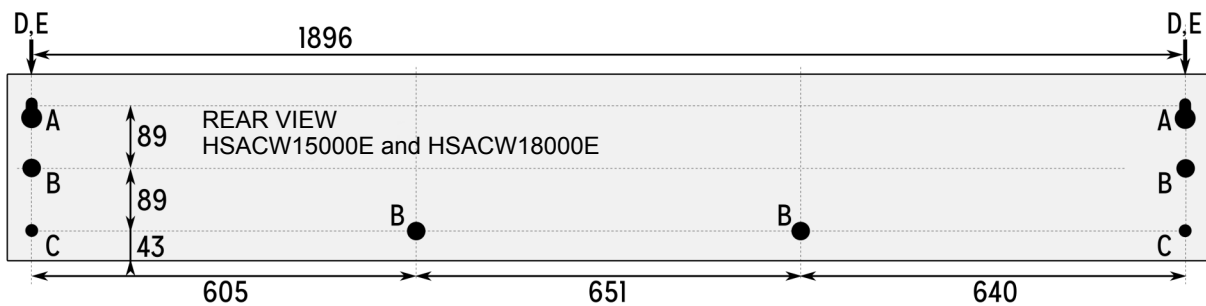
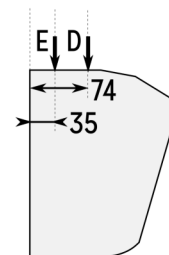
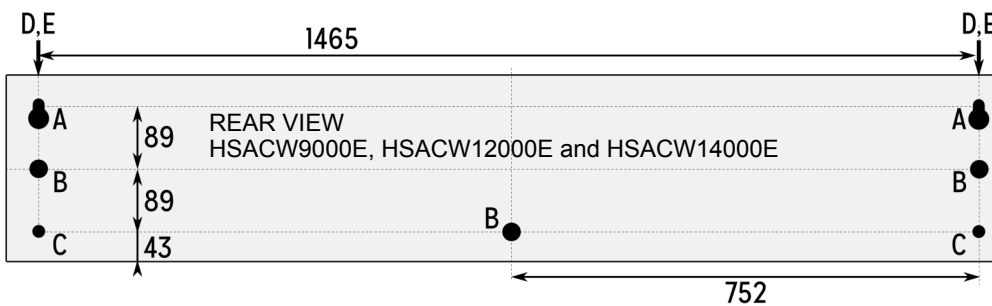

NOT TO SCALE DIMENSIONS IN MM

4. Technical Specifications

4.1 General Data		HSAC9000E	HSAC12000E	HSACW9000E	
Maximum height	M	3.4			
Door width	M	1.3	1.3	1.5	
Heat medium		Electric heating element			
Heat output	kW	9	12	9	
Fan type		2x EC Crossflow 100mm			
Fan control		Electronic fan speed control			
Heat switching		Solid state electronic control			
Weight	kg	18	18	20	
Electrical Data					
Supply voltage		415V 3ph 50Hz but can be adapted to 1 phase	415V 3ph 50Hz		
Total load	kW	9	12	9	
Max current per phase	A/pha	13	16.5	13	
Max motor power	W	2 x 48	2 x 48	2 x 48	
External fuse size amps	A/pha	16	20	16	
Controller		Remote switch or Touch colour screen controller			
Controller wiring		4 core 1mm ² or CAT5 / CAT6 with RJ45 connectors			
Cable terminal size		10mm ² Max			
Mains terminal block position		Centre of base unit. Terminals N; L1; L2 & L3			
Control terminal position		Centre of base unit			
Air Data					
Air volume	<i>Max speed</i>	m ³ /h	1600	1600	1920
Air velocity	<i>Max speed @ 0M</i>	m/s	6.8		
	<i>Max speed @ 1M</i>	m/s	4.2		
	<i>Max speed @ 2M</i>	m/s	3		
	<i>Max speed @ 3M</i>	m/s	2		
Max Delta T @ 10°C	<i>Auto speed</i>	°C	29	39	26
Noise level @ 3m	<i>Max speed</i>	dBA	60		
	<i>Min speed</i>	dBA	50		
Dims Data					
Length	mm	1305	1305	1530	
Width	mm	205			
Height	mm	264			

4. Technical Specifications

4.1 General Data		HSACW12000E	HSACW14000E
Maximum height	M	3.4	
Door width	M	1.5	1.5
Heat medium		Electric heating element	
Heat output	kW	12	14
Fan type		2x EC Crossflow 100mm	
Fan control		Electronic fan speed control	
Switching type		Solid state electronic control	
Weight	kg	20	20
Electrical Data			
Supply voltage		415V 3ph 50Hz	
Total load	kW	12	14
Max current per phase	A/pha	16.5	19.5
Max motor power	W	2 x 48	2 x 48
External fuse size amps	A/pha	16	20
Controller		Remote switch or Touch colour screen controller	
Controller wiring		4 core 1mm ² or CAT5 / CAT6 with RJ45 connectors	
Cable terminal size		10mm ² Max	
Mains terminal block position		Centre of base unit. Terminals N; L1; L2 & L3	
Control terminal position		Centre of base unit	
Air Data			
Air volume	<i>Max speed</i>	m ³ /h	1920
Air velocity	<i>Max speed @ 0M</i>	m/s	6.8
	<i>Max speed @ 1M</i>	m/s	4.2
	<i>Max speed @ 2M</i>	m/s	3
	<i>Max speed @ 3M</i>	m/s	2
	Max Delta T @ 10°C	<i>Auto speed</i>	°C
Noise level @ 3m	<i>Max speed</i>	dBA	60
	<i>Min speed</i>	dBA	50
Dims Data			
Length	mm	1530	1530
Width	mm	205	
Height	mm	264	

4. Technical Specifications

4.1 General Data		HSACW15000E	HSACW18000E	
Maximum height	M	3.4		
Door width	M	2	2	
Heat medium		Electric heating element		
Heat output	kW	15	18	
Fan type		3x EC Crossflow 100mm		
Fan control		Electronic fan speed control		
Switching type		Solid state electronic control		
Weight	kg	25	25	
Electrical Data				
Supply voltage		415V 3ph 50Hz		
Total load	kW	15	18	
Max current per phase	A/pha	16.5	19.5	
Max motor power	W	3 x 48	3 x 48	
External fuse size amps	A/pha	25	32	
Controller		Remote switch or Touch colour screen controller		
Controller wiring		4 core 1mm ² or CAT5 / CAT6 with RJ45 connectors		
Cable terminal size		10mm ² Max		
Mains terminal block position		Centre of base unit. Terminals N; L1; L2 & L3		
Control terminal position		Centre of base unit		
Air Data				
Air volume	<i>Max speed</i>	m ³ /h	2400	2400
Air velocity	<i>Max speed @ 0M</i>	m/s	6.8	
	<i>Max speed @ 1M</i>	m/s	4.2	
	<i>Max speed @ 2M</i>	m/s	3	
	<i>Max speed @ 3M</i>	m/s	2	
	Max Delta T @ 10°C	<i>Auto speed</i>	°C	27
Noise level @ 3m	<i>Max speed</i>	dBA	60	
	<i>Min speed</i>	dBA	50	
Dims Data				
Length	mm	1970	1970	
Width	mm	205		
Height	mm	264		

5. Wiring Details

5.1 Installer Wiring

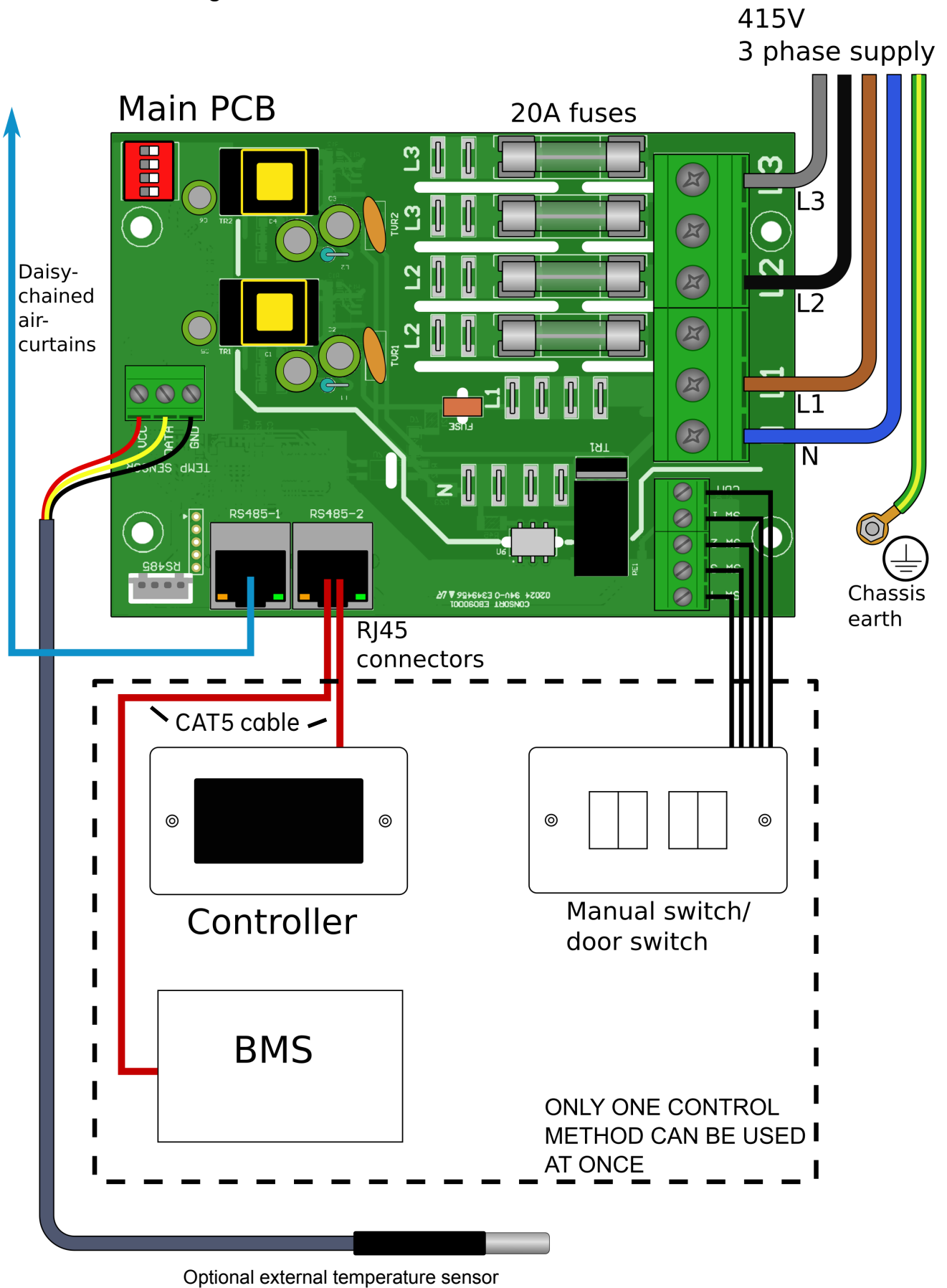

5.2 Factory Wiring

3-Phase default wiring

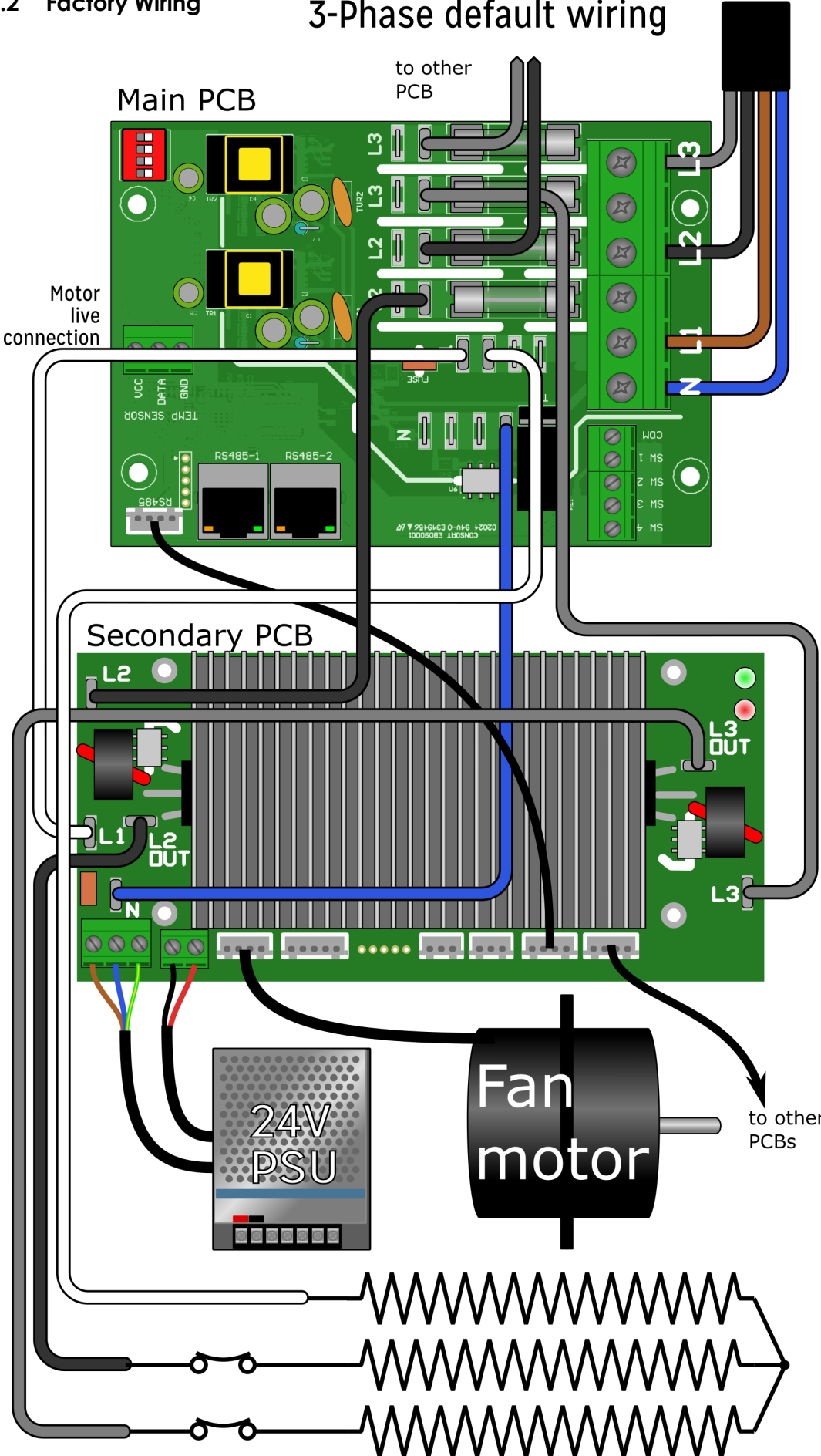

5.3 Network Wiring - Controller

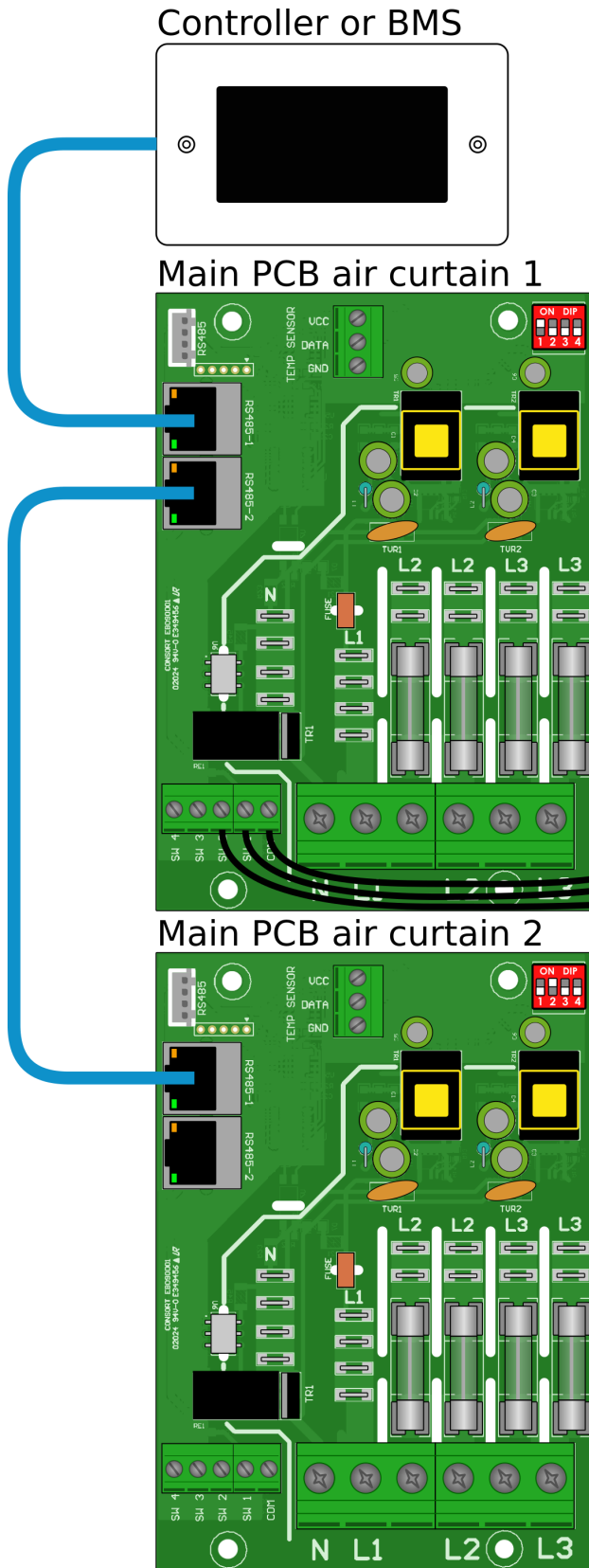

To connect the air curtain with a controller, switch first three switches to 100X with X being dependant on the installation height (refer to page 12).

CAT5 cable with RJ45 connectors can be used to network up to 7 air curtains in a daisy-chain configuration.

The DIP switches 1, 2 and 3 are used to configure each air curtain with a unique address.

DIP switch setting 000X is reserved for when a controller or BMS is not used.

For example: air curtain 1, DIP switches set to 1000.

This is so the controller can communicate with each individual air curtain as they each have a unique combination of DIP switches.

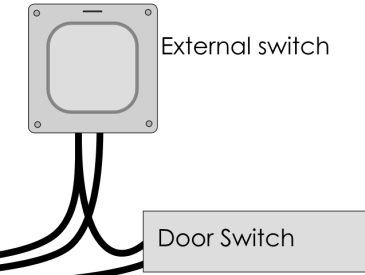

External and door switches are connected between COM and SW1 or SW2. Their behaviour can be configured in the controller settings menu.

E.g. air curtain 2 DIP switches set to 0100.

All possible addresses are:

- 1 100X
- 2 010X
- 3 110X
- 4 001X
- 5 101X
- 6 011X
- 7 111X

5.4 Network Wiring - Switches

Main PCB air curtain 1

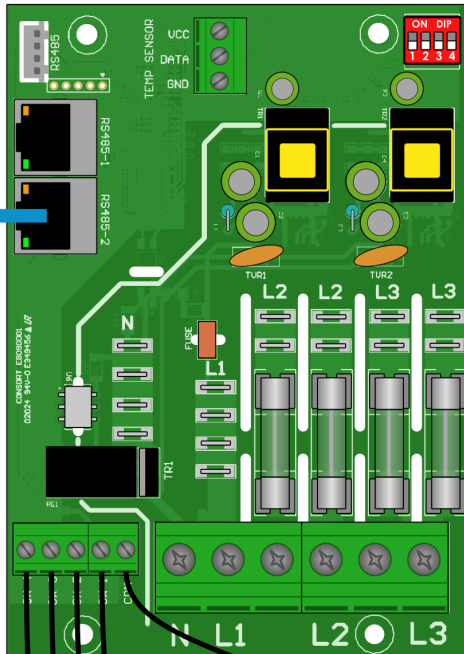

The aircurtain can be also controlled by mechanical switches. In this configuration touchscreen controller or BMS controls will not work.

To operate heater by mechanical switches, the DIP switches on the main pcb need to be set to 000X.

The DIP switch 4 is used to select fan speed range.

For installation height of 2 - 3m set the DIP switches to 0000.

For installation height of 3 - 4m set the DIP switches to 0001.

- SW1 - on / off
- SW2 - low speed / high speed
- SW3 - 1/3 heat output
- SW4 - 2/3 heat output

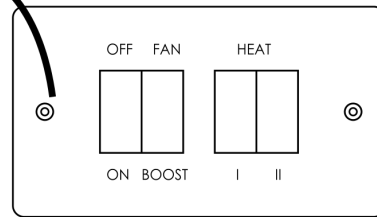
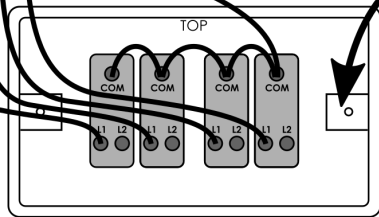

Main PCB air curtain 2

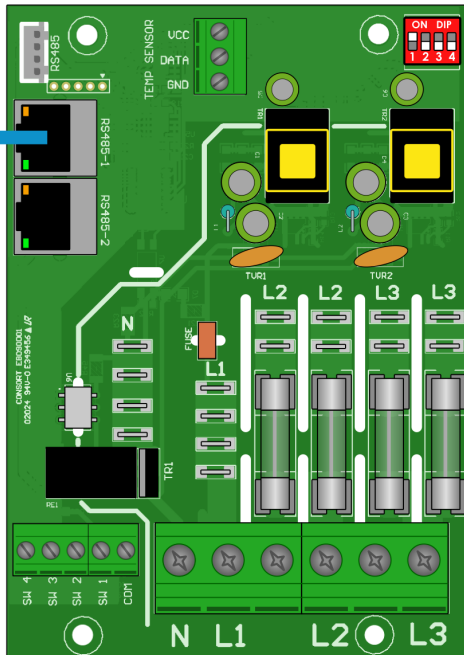

CAT5 cable with RJ45 connectors can be used to network up to 7 air curtains in a daisy-chain configuration.

The 2 DIP switches on all 7 connected air-curtains must be set to different addresses.

All possible addresses are:

- 1 100X
- 2 010X
- 3 110X
- 4 001X
- 5 101X
- 6 011X
- 7 111X

6. Modification for use on single phase (HSAC9000E only)

The HSAC9000E is supplied as 3 phase only appliance. In order to use it with a single phase supply, the internal wiring has to be modified. The appliance is supplied with a single phase conversion kit. The pictures below describe how to change the internal wiring. After the internal wiring has been modified it is necessary to change labelling of the connector as shown on the picture below and also new rating label showing single phase supply must be use to cover the existing 3 phase operation rating label.

This has to be followed exactly.

6.1 3 phase internal wiring

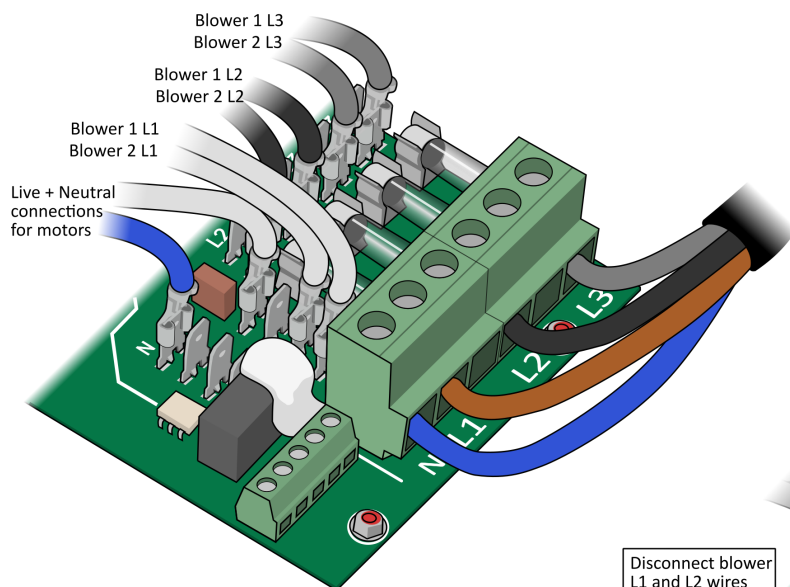

6.2 Single phase internal wiring

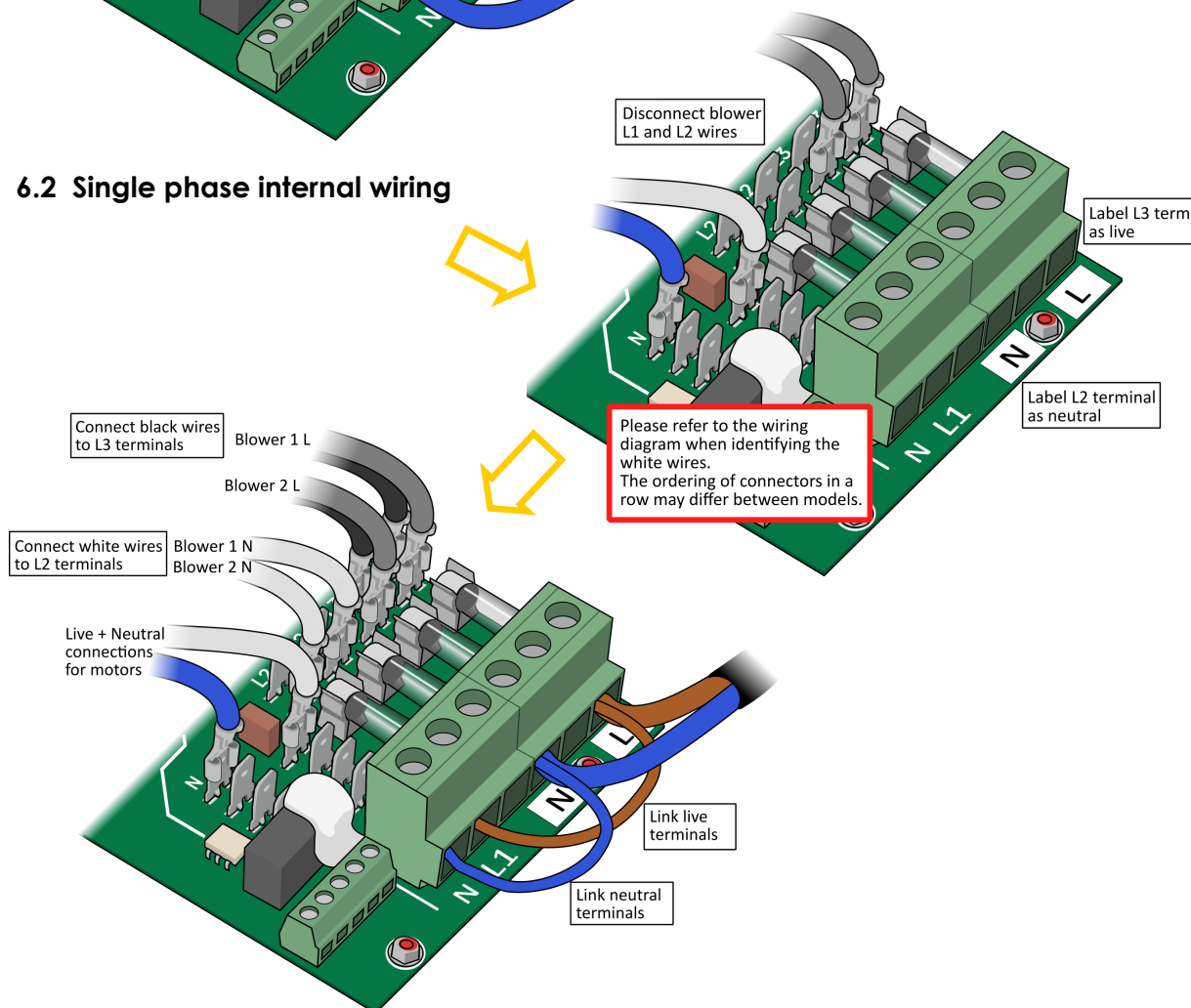

6. Modification for use on single phase (HSAC9000E only)

6.3 Internal wiring of the heating element for 3 phase operation

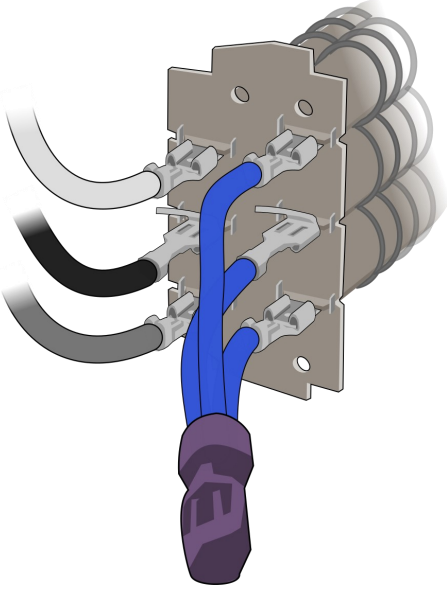

6.4 Modification of internal wiring of the heating element for single phase operation

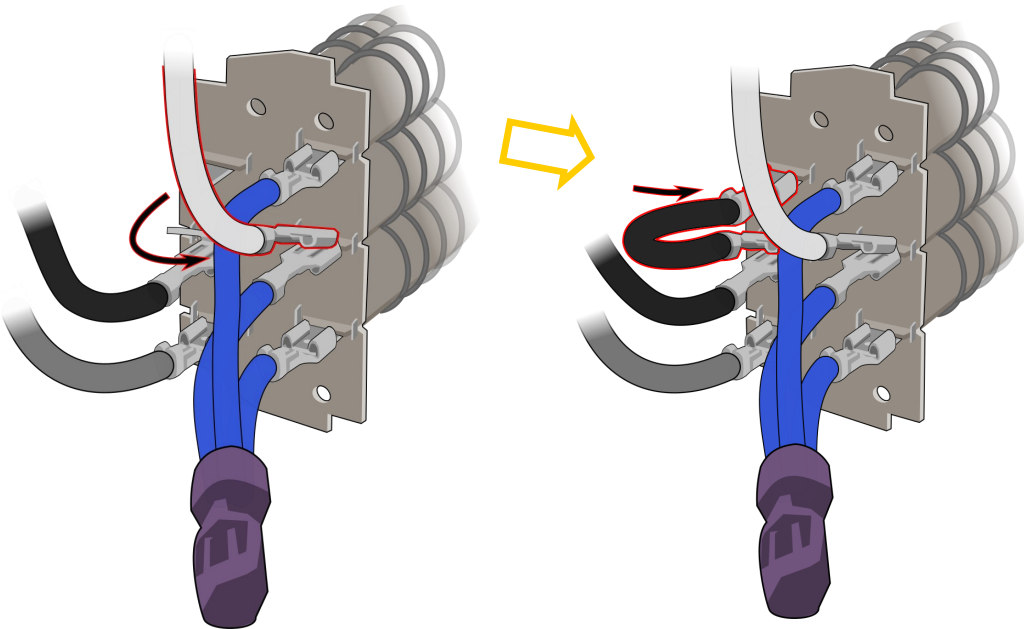

6. Modification for use on single phase (HSAC9000E only)

6.5 Modification for use on single phase (HSAC9000E only)

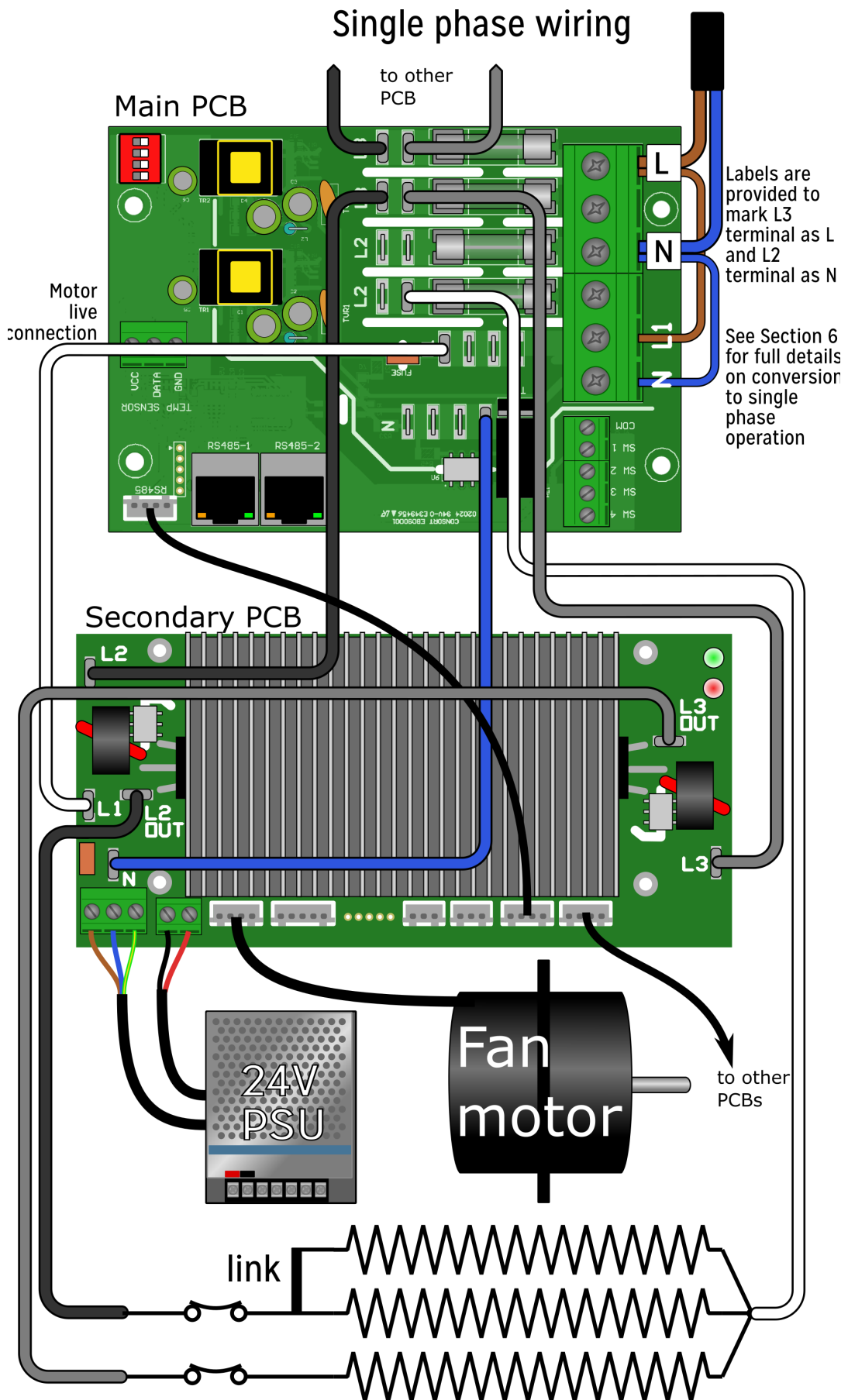

7. Installation Details

7.1 Screw location for grille removal

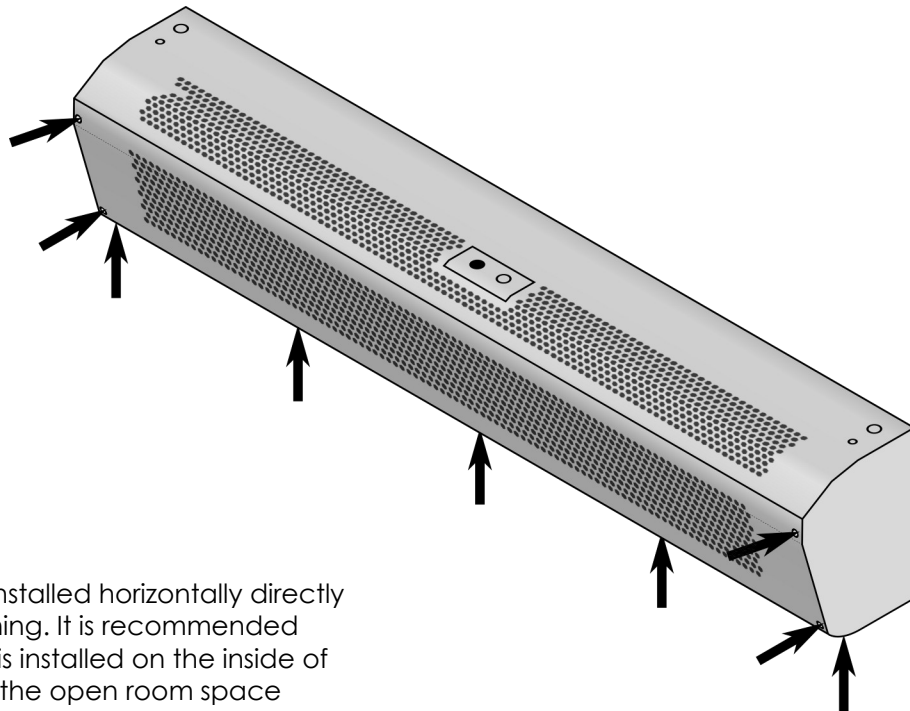

7.2 Mounting

All units should be installed horizontally directly over the door opening. It is recommended that the air curtain is installed on the inside of the building, within the open room space against a wall or ceiling.

Care must be taken to allow complete free air movement into the inlet grilles of the unit to ensure correct working operation of the air curtain. The discharge opening should be as close to the top of the door as possible and must cover the entire door width.

Units can be mounted adjacent to each other to cover the full door opening across wider entrances.

7.3 Electrical Supply

The cable entry is located on the top centre of the heater. Cable entry is located on a removable bracket for easier installation. The heater is supplied with two 20mm cable glands. The cable gland holes can be enlarged by removing excess metal to 25mm. The bracket is secured by two hex head screws.

7.4 Installation

It is the sole responsibility of the installer to ensure that the points of attachment to the building are sound. Consultation with the consultant/architect or owner of the building is recommended to ensure that a sound, mechanically stable installation is achieved.

All attachments must be capable of supporting the weight of the product .

Step 1

Carefully unpack the heater.

Step 2

Remove the grille by loosening screws as shown on the picture above.

Step 3

For wall mounting:

The heater can be fixed to the wall using 6mm or 10mm holes provided.

Mark and drill required holes as explained in section 3 and fix heater to the wall.

For suspending from the ceiling:

Either drop rods or catenary wire can be used to fasten the air curtain to the ceiling support structure. The mounting points can be seen in section 3.

Step 4

Remove cable entry bracket.

Connect electrical supply , optional door switches and external sensor to appropriate terminals and reattach the bracket.

Step 5

Test the heater.

Step 6

Refit the heater grille.

8. Fault detection and LEDs

8.1 Fault detection

When the air curtains are powered up in standby mode, a green LED on the main board shows that the 12V power supply is working correctly:

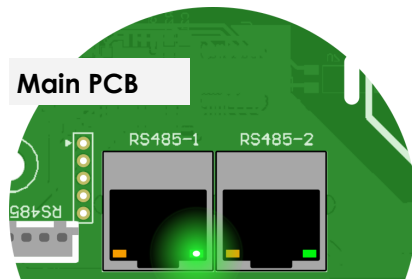

When heat or cold blow is demanded the secondary PCBs are powered. A second LED on the main PCB shows that the second 12V power supply is working correctly:

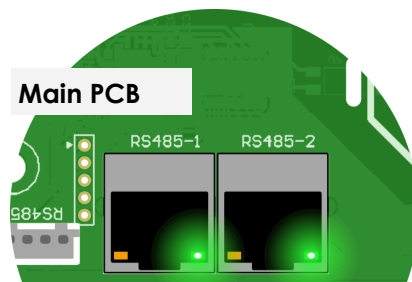

A fault with the auxiliary power is indicated by a flashing orange LED on the main PCB:

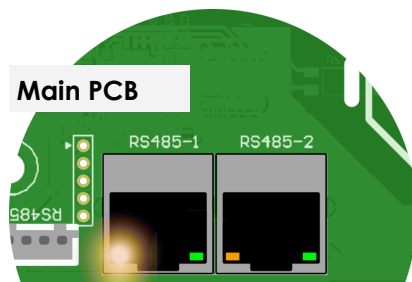

A green LED on the secondary PCBs shows that they are receiving 12V power:

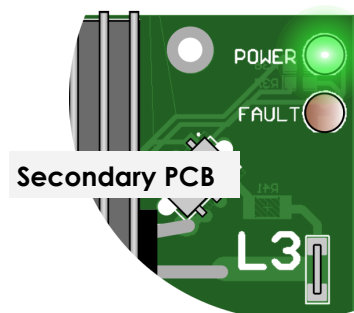

The air curtain monitors the fan speed, power output and heatsink temperature. In the event of a fault the red LED on the secondary PCB flashes:

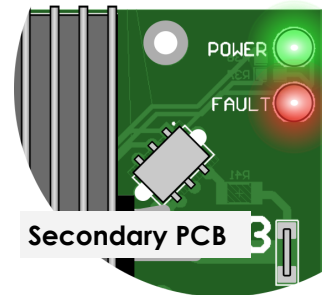

The red LED flashes a number of times and then pauses. The number of flashes denotes the fault

Number of flashes	Fault
1	Power measurement when triacs switched off: Response: Auto run motor
2	Motor fault Response: Disable heating
3	Triac heatsink overheat: Response: Reduce heating
4	Low power measurement when triacs switched on: Causes: Thermal cut-out operated, blown fuse, missing phase

8.2 Over heat protection reset

The heater is equipped with electronic over heat protection and also over temperature cut-outs. There are two cut-outs they can be either auto or manual reset on each blower module on the top of the heating element. The HSAC9000E, 12000E, HSACW9000E, 12000E, 14000E heaters have four cut-outs in total and HSACW15000E, 18000E six cut-outs. In the unlikely event of electronic failure, the mechanical cut-outs will switch off power to the heating element. In order to reset cut-outs, isolate the heater from power, allow the heater to cool and remove the cover. If your heater is equipped with manual cut-outs there will be a small plastic push button on the top of each cut-out, push this to reset. Auto cut-outs will reset automatically when unit is isolated and cooled down. **The cause of cut-outs operating should be investigated before resetting**

9. BMS Connection MODBUS Protocol

9.1 BMS Connection

The heater is compatible with BMS systems using MODBUS protocol.

The connection to BMS system can be made using one of the RJ45 connectors.

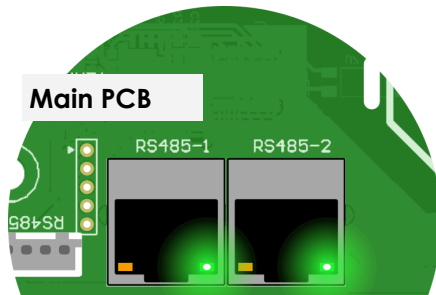

Only one means of control can be used at any time. If BMS is used to control the heater, the colour screen controller must not be used.

The BMS can control fan speed and heat output and also read and report the heater status.

Speed can be set in the range of 600 - 1700RPM in 1RPM steps. If the speed is set below 600RMP, the heating element is automatically disabled. Care has to be taken when selecting speed. The fan speed should be always correct for the selected heat output. If the speed is too low, the heater can overheat.

Heat output can be set in the range of 0 - 100% in 1% steps.

9.2 MODBUS Protocol



The DIP switches 1, 2 and 3 are used to configure each air curtain with a unique address.

RJ45 cable can be used to network up to 7 air curtains in a daisy-chain configuration.

DIP switch setting 000X is reserved for when a controller or BMS is not used.

All possible addresses:

1	100X
2	010X
3	110X
4	001X
5	101X
6	011X
7	111X

RS485 serial half-duplex interface
 MODBUS RTU
 9600 baud
 8 bits
 1 start bit
 no parity + 2 stop bits
 'mark' parity + 1 stop bit

Supported MODBUS function codes:

0x03 read multiple input registers
 0x04 read multiple holding registers
 0x06 write single holding register
 0x10 write multiple holding registers

16 Bit Input Registers:

1 Status
 2 Temp 1
 3 Temp 2
 4 Temp Heatsink
 5 Temp External
 6 External Switches

Temperatures are formatted as 16 bit signed integers. Units are sixteenths of a degrees Celsius, as used by DS18B20 temperature sensors. The hex value 0xF000 is used to denote an invalid reading.

The status register uses bits to indicate faults:

Bit 0 - overheat
 Bit 1 - heatsink overheat
 Bit 2 - temp sensor 1
 Bit 3 - temp sensor 2
 Bit 4 - heatsink temp sensor
 Bit 5 - remote temp sensor
 Bit 6 - L2 on current low
 Bit 7 - L2 off current high
 Bit 8 - L3 on current low
 Bit 9 - L3 off current high
 Bit 10 - motor PSU
 Bit 11 - motor
 Bit 12 - MCU
 Bit 13 - connection
 Bit 14 - 12V auxiliary power
 Bit 15 - main PCB relay

External switches register uses bits to show the state of switches:

Bit 0 - Switch 1
 Bit 1 - Switch 2
 Bit 2 - Switch
 Bit 3 - Switch 4

16 Bit Holding Registers:

1 RPM (units revolutions per minute)
 2 Power (units percentage 0 -100)
 RPM must be set to at least 600, otherwise heating is disabled.

10. Touchscreen Controller Operation

10.1 Home Screen

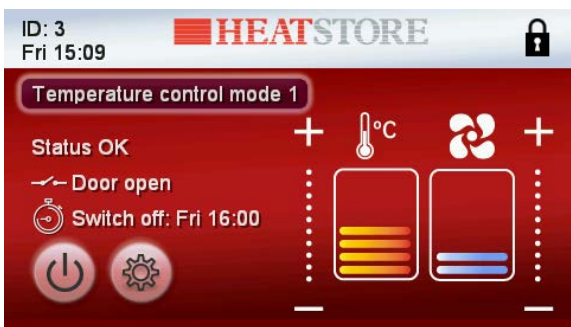

The home screen provides information about the heater status and all relevant functions.

- Time
- Operating mode
- Heater status
- Door switch status
- Timer status
- Heat output
- Fan speed
- ON / Stand-by button
- Settings menu button

10.2 Settings menu

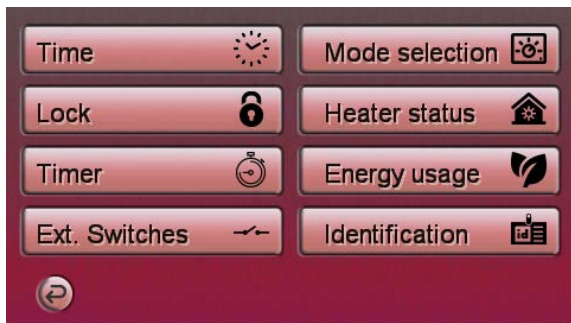

All functions and settings are available from this menu.

10.3 Time



The time can be set using the arrow buttons. A coin battery CR1220 maintains the time when power is interrupted. Time is displayed on the home screen and needs to be set to use the timer function.

10.4 Lock

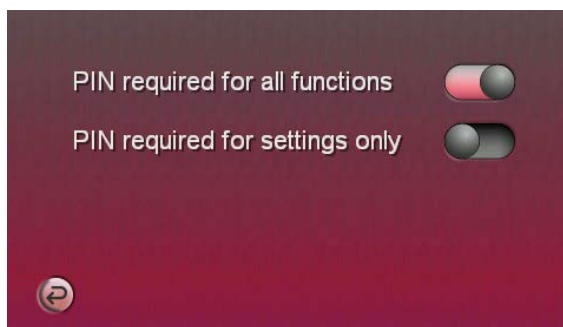

PIN function can be enabled to prevent unwanted operation of the heater or changing the settings.

The PIN can be completely disabled, enabled for settings only or all functions.

The default Pin is set as **1234**, but can be changed using the Change Pin button. If the PIN is forgotten contact Heatstore technical help.

10.5 Timer

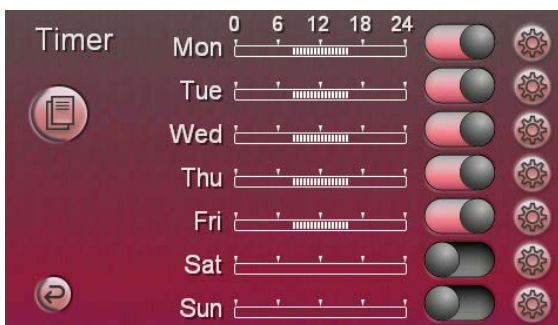

The 7 day timer function allows scheduling automatic switching between on and stand-by. Each day can be individually enabled or disabled. The timer allows up to two periods of operation per day. The white bars indicate when the heater is timed to switch on.

Use the settings buttons to set up the time for each day (see next page), and the copy button to copy settings from one day to another.

10. Touchscreen Controller Operation - cont.

10.6 Timer - time schedule



There are 2 timer periods for each day available. Tapping the slider in the top right corner will change between 1 or 2 time periods.

The times for the first time periods are on the top of the screen, the times for the second timer period are on the bottom of the screen. Times can be adjusted in 15 minute intervals using the buttons.

When the timer is active, an icon will appear on the home screen giving information about the next switch time.

10.7 External switches

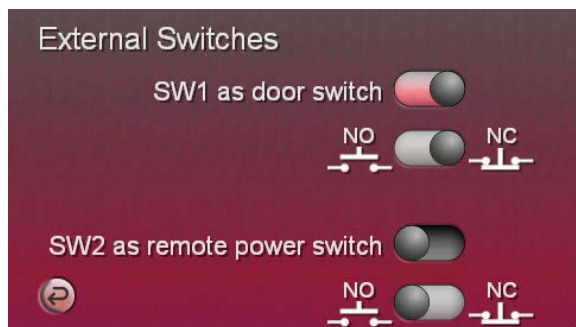

There is a provision for 2 remote switches than can be wired into the air curtain with. The switches must be voltage free type, NO or NC configuration.

SW1 can be connected to a door switch or occupancy sensor installed in the door area. When the function is activated, the door switch will enable the air curtain when the door is open and disable it when the door is closed. The second slider is used to configure the system for the correct switch type. When the air curtain is disabled by the door switch, the heater will operate at a low fan speed. This will allow for a fast start-up when the door is opened. When SW1 is active, the home screen will show the status of the door switch.

SW2 is intended for a remote switch that can be used to disable the air curtain from a remote location. Usually this would be a simple BMS or external timer connection. Once disabled using remote switch the air curtain can't be controller by the touchscreen controller and will remain disabled until enabled remotely.

10.8 Operating Mode selection



One of four operating modes can be selected. Each mode uses a different method of selecting heat and fan settings when the air curtain is not in stand-by mode. Use the settings button to configure each mode.

10.9 Manual Mode

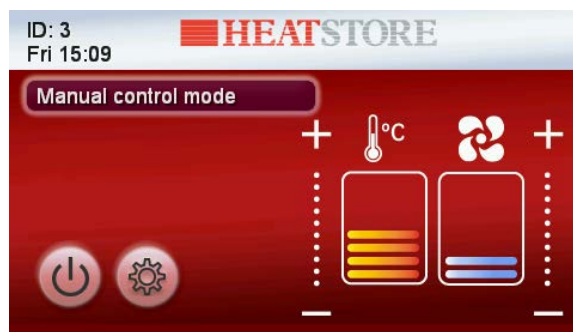

In manual mode user can select required fan and heat output by tapping + or - symbols on the home screen next to the fan and heat bars.



There are 8 fan speeds and 8 heat settings available. It is possible set maximum and minimum limits for fan speed and heat output. Once limits are set and functions activated, only limited fan speed and heat output will be available on home screen when in manual mode.

10. Touchscreen Controller Operation - cont.

10.10 Automatic Mode

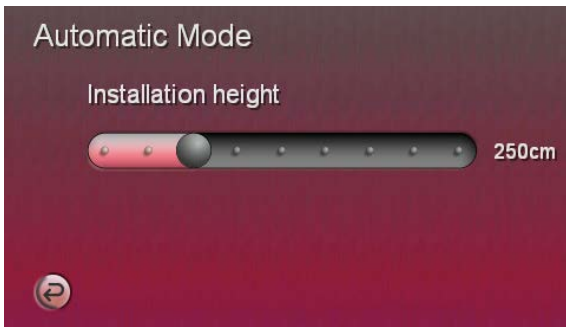

Automatic Mode is the best choice for easy to set-up efficiency and comfort. Set the height by moving slider to the required position. The air curtain will run at optimum fan speed and heat output based on the inlet temperature.

10.11 Temperature Mode 1

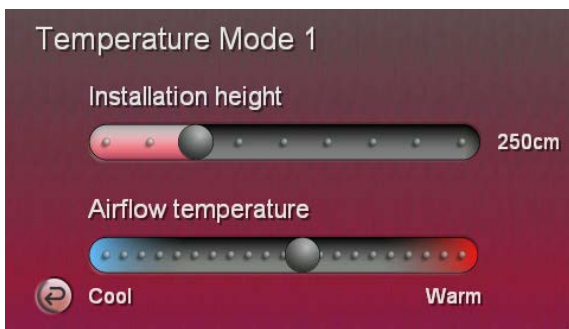

Temperature Mode 1 is very similar to Automatic Mode, with the addition of having an option for adjusting the airflow temperature. With the airflow temperature set in the middle of the scale, this is equivalent to Automatic Mode.

In certain situations, when required, airflow can be increased or decreased by increasing or decreasing the set installation height. Using a higher setting for the installation height will make the air curtain less energy efficient.

10.12 Temperature Mode 2

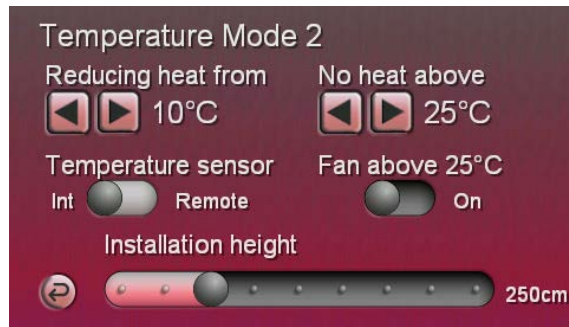

This operating mode is suitable for situations where the heater is used to maintain the room temperature or where the requirement is to adjust the heat output based on the indoor/outdoor temperature.

This operating mode can use either the internal or supplied external temperature sensor.

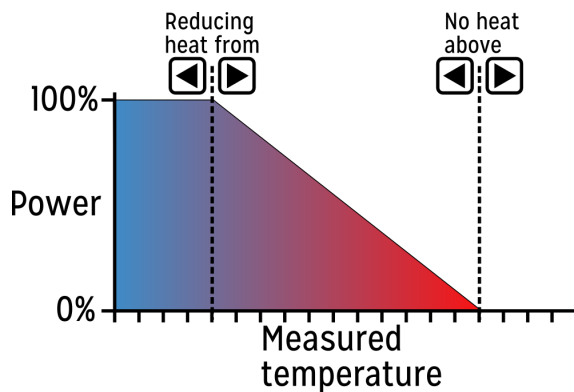

The temperature on the left defines the starting point below which the air curtain uses full power. The temperature on the right defines the point above which the air curtain doesn't produce any heat. As the measured temperature rises the heat output is gradually reduced until heater doesn't produce any heat.

Using the internal temperature, this mode can be used to maintain room temperature. With remote sensor installed outside, this mode can be used to compensate for external temperature. There is also an option to select fan function after the heater stops producing heat. Fan can be set to turn off after the heater stops producing heat or run all the time.

11. Touchscreen Controller Operation - cont.

10.13 Heater status

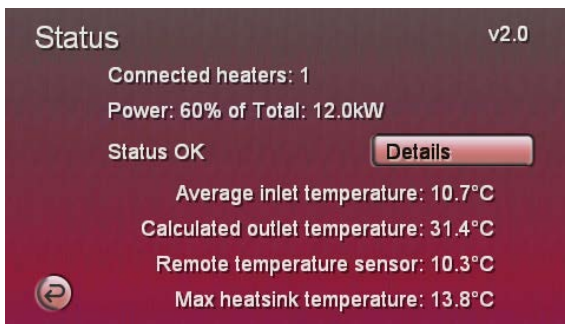

The Status screen provides an overview of values from all connected heaters. The heaters need to be run before some of the values can be calculated.

In the event of a fault a red warning triangle is displayed:

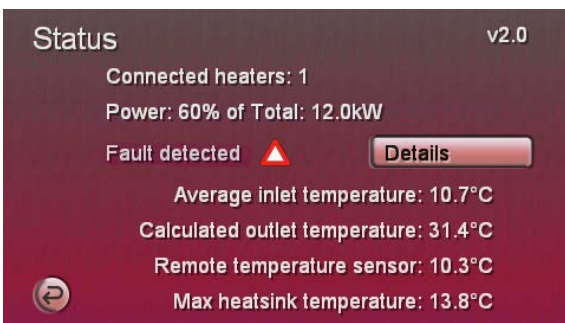

More details are available when tapping the details button. The detailed status screens are primarily for installers or engineers to help with installation or fault diagnostics.

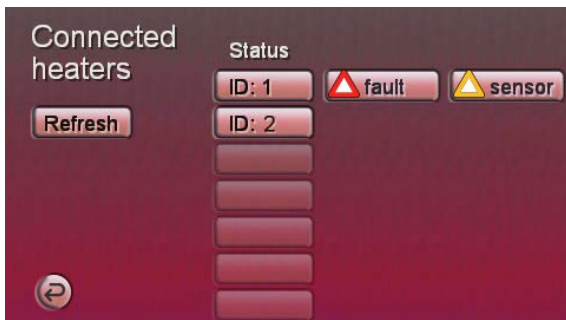

The connected heaters screen shows all of the currently connected heaters, in order of address ID. Heaters are connected when the controller is first powered up. In order to connect to newly powered heaters, press Refresh to search for heaters.

For each connected heater, up to 3 detailed status screens are available. These are general status, faults and sensor screens.

The links to the faults and sensor screens are hidden when no faults have been identified.

10.13 Heater status - cont.

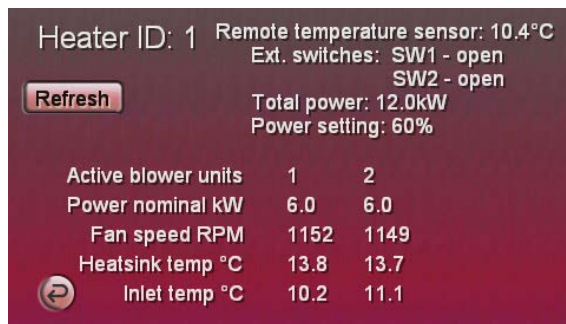

The general status screen shows details about the heater and all of the internal blower units. The heater needs to be run before some of the values can be calculated.

The faults screen can provide detailed diagnostics of faults for each internal blower unit. The sensor screen shows the status of the temperature sensors.

10.14 Energy usage

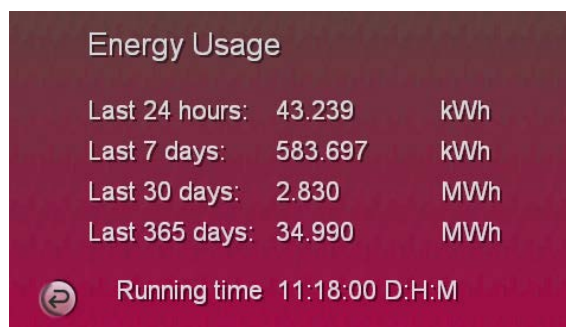

The energy usage screen provides information related to energy used from the day the heater was installed. The values are calculated based 3PH 400V and so will differ from actual energy usage when mains voltage is lower or higher.

10.15 Identification

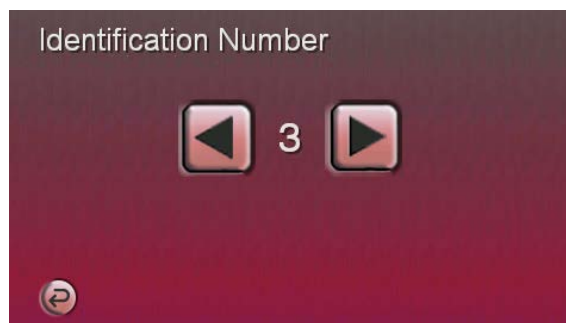

User can set ID number for controller identification. This number is shown on the left hand corner of the home screen. This feature is useful in situation where there are more than one controller side by side.



THE TOTAL ELECTRIC HEATING SOLUTION



Declaration Of Conformity

In accordance with UK Government Guidance.
WE HEREBY CERTIFY THAT THE APPLIANCES DETAILED HEREON HAVE BEEN
INSPECTED AND TESTED, AND CONFORM TO THE REQUIREMENTS OF THE
FOLLOWING UK STATUTORY INSTRUMENTS WHERE APPLICABLE:

- Electrical Equipment (Safety) Regulations 2016 SI. 2016 1101**
- Electromagnetic Compatibility Regulations 2016 SI. 2016 No. 1091**
- Radio Equipment Regulations 2017 SI. 2017 No. 1206**
- The Ecodesign for Energy Related Products and Energy Information (Amendment) (EU Exit) Regulations 2019. SI. 2010 2617**
- The Restriction of use of Certain Hazardous Substances. SI. 2012 No. 3032**
- The Waste Electrical and Electronic Equipment Regulations 2013. SI. 2013 No. 3113**
- Security Requirements for 'Connectable Products' PTSI Acts 2022**

Transposed standards used:

- **BSEN55014 (2006)**
- **BSEN301 489.1 & .3**
- **BSEN300 220.1 & .2**
- **BSEN60 730.2.9**
- **BSEN 60335.1 (2012)**
- **BS EN 60335.2.30 (2009)**
- **ETSI BSEN 303 645**

PART NUMBER:

HSAC9000E, HSAC12000E, HSACW9000E,
HSACW12000E, HSACW14000E, HSACW15000E,
HSACW18000E

NAME OF RESPONSIBLE PERSON:
POSITION:
DATE:

Martyn Field
Technical Manager
30/10/24

Contact details

Heatstore
Unit 12, Access 18, Bristol, BS11 8HT
Telephone: 0117 923 5375 Email: enquiries@heatstore.co.uk
<http://www.heatstore.co.uk>

