

 **HEATSTORE**

OPERATING MANUAL

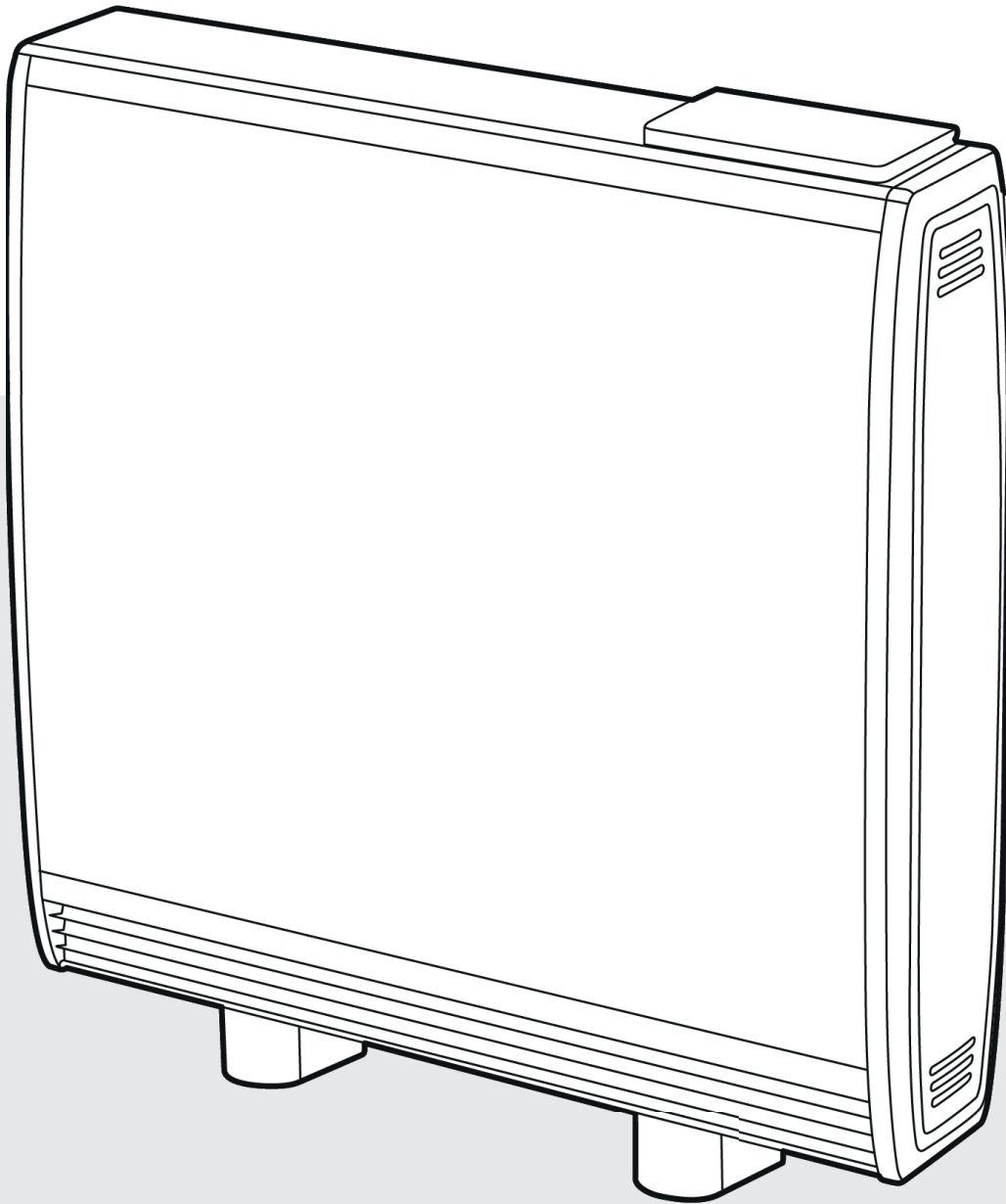

Dynamic HHR Storage Heater

Models: HSDHHR050, HSDHHR070, HSDHHR100

HSDHHR125, HSDHHR150



IMPORTANT

THESE INSTRUCTIONS SHOULD BE READ CAREFULLY AND RETAINED FOR FUTURE REFERENCE. **Note also the information presented on the appliance**



Warnings in this document are identified by a warning triangle against a grey background.

Keywords at the start of a warning indicate the type and seriousness of the ensuing risk if measures to prevent the risk are not taken.

The following keywords are defined and can be used in this document:

- **DANGER** indicates a hazardous situation which, if not avoided, will result in death or serious injury.
- **WARNING** indicates a hazardous situation which, if not avoided, could result in death or serious injury.
- **CAUTION** indicates a hazardous situation which, if not avoided, could result in minor to moderate injury.
- **NOTICE** is used to address practices not related to personal injury.

CAUTION

FAILURE TO FOLLOW THESE INSTRUCTIONS MAY CAUSE INJURY AND/OR DAMAGE AND MAY INVALIDATE YOUR GUARANTEE

IMPORTANT SAFETY ADVICE

When using electrical heaters, basic precautions should always be followed to reduce the risk of fire, electrical shock, and injury to persons, including the following:

IMPORTANT – The wall bracket supplied with the heater must be used.

IMPORTANT – All packaging should be disposed of in an appropriate manner.

OVERHEATING WARNING

WARNING - In order to avoid overheating, do not cover or obstruct the heater. Do not place material or garments on the heater, or obstruct the air circulation around the heater, for instance by curtains or furniture, as this could cause overheating and a fire risk. **NEVER** cover or obstruct in any way the heat outlet slots at the top of the heater or the air outlet slots in the base of the heater.

WARNING - THE SURFACES ON THIS HEATER CAN BE HOT.



The heater carries a warning 'DO NOT COVER' to alert the user to the risk of fire that exists if the heater is accidentally covered.

CAUTION - **Some parts of this product can become very hot and cause burns. Particular attention has to be given where children and vulnerable people are present.**

For your safety this heater is fitted with a thermal cut-out. In the event that the product overheats for some reason, the cut-out prevents excessive temperatures on the product by cutting the power to the heater. Once the heater has cooled down, it will reset automatically, it will continue to cycle on and off automatically until the reason for overheating is removed.

The display screen may flash red to indicate the product has overheated. To reset the display, remove the obstruction and hold **Enter** for 10 seconds.

SUITABLE APPLICATIONS

WARNING - This heater is suitable for normal dwelling purposes and should not be used in any other type of environment. This product should only be used in the country where it was purchased from by a recognised commercial retailer. **Do not use outdoors.**

SERVICING AND REPAIRS

WARNING - Servicing and product repairs should only be undertaken by the manufacturers approved service agent or a similarly trained or qualified person, using only exact manufacturer approved spare parts.

PLEASE NOTE: Household dust, lit cigarettes, candles and oil burners, combined with the convection effect of electric heaters can cause significant soot deposits to build up on the surface directly above and to the sides of the heater. This is not a fault of the heater. Extensive burning of candles or smoking in the operating environment of this product can produce heavy discolouration within a few months of use.

OPERATING WARNINGS

IMPORTANT: Remember to observe all safety warnings and precautions when operating the heater on the automatic or timer modes, either attended or unattended since a fire risk exists when the heater is accidentally covered, obstructed or displaced.

CAUTION: Do not use if either of the heater's mains power leads become damaged. If the supply cord is damaged it must be replaced by the installer or an approved Heatstore service partner.

Do not sit or stand on the heater.

Ensure minimum clearances between the heater and other objects / surfaces are maintained.

ELECTRICAL INSTALLATION

WARNING - Minimum clearances and IP zone requirements must be adhered to in accordance with the current wiring regulations.

Mains cables are not provided with this heater.

WARNING - The electrical installation of this heater must be carried out by a suitably qualified or trained electrician, and be in strict accordance with current wiring regulations.

The peak supply must be connected via a switched fused spur with a fuse rated suitably for the appliances flex, the off-peak supply, via a 20A double pole isolated switch. In both instances a plug and socket arrangement **MUST NOT** be utilised. The contact separation to be a minimum of 3mm.

If the product is installed as a single supply (see page 17 of Installation Instruction for more details), a 20A DP switch must be used as the supply is covering peak and off peak loads.

Failure to follow these instructions will mean that the manufacturer's instructions have not been adhered to. **THERE ARE NO EXCEPTIONS.**

- This heater must be earthed
- Not suitable for connection via a plug top
- Do not locate the heater immediately above, below or in front of a fixed electrical point i.e. socket outlet.

This appliance is intended for installation to a single phase supply only and is not suitable for connection to 3 phase supplies.

ELECTRICAL INSTALLATION continued

The heater is not fitted with a mains cable, this should be fitted by the installer. Cable type (minimum size) H05V2V2-F 1.5mm² three core for peak and 2.5mm² three core for off-peak for connection to the fixed wiring of the premises through suitable isolation devices positioned adjacent to the heater. The supply circuits to the heater must incorporate a double pole isolating switch having a contact separation of at least 3mm.

In installation the supply cord must be cut to the appropriate length for the electrical connection point. Excess cable should not be inserted or stored behind the heater.

If, during reassembly of the heater, a part of the thermal insulation shows damage or deterioration, it should be replaced by an identical part.

WARNING: All electrical connections to the terminal block must be secure to prevent risk of ignition. Tighten to 2 Nm.

CHILD SAFETY

WARNING - Fixing kit screws are a potential choking hazard.

WARNING - This appliance is not intended for use by persons (including children) with reduced physical, sensory or mental capabilities, or lack of experience and knowledge, unless they have been given supervision or instruction concerning use of appliance by a person responsible for their safety.

This appliance can be used by children from 8 years and above and persons with reduced physical, sensory or mental capabilities or lack of experience and knowledge if they have been given supervision or instruction concerning use of the appliance.

Children shall not play with the appliance.

Cleaning and user maintenance shall not be made by children without supervision.

Children of less than 3 years should be kept away unless continuously supervised.

Children aged from 3 years and less than 8 years shall only switch on/off the appliance provided that it has been placed or installed in its intended normal operating position and they have been given supervision or instruction concerning use of the appliance in a safe way and understand the hazards involved.

Children aged from 3 years and less than 8 years shall not regulate and clean the appliance or perform user maintenance.

WARNING - KEEP BATTERIES OUT OF REACH OF CHILDREN

WARNING - Packaging should be disposed of responsibly as the EPS used could be a potential choking hazard for children.



This document is customer property and is to remain with this unit.

These instructions do not cover all the different variations of systems nor does it provide for every possible contingency to be met in connection with installation.



WARNING: EARTHING

This appliance must be earthed in accordance with the manufacturers recommendations and in accordance with IEE regulations for electrical equipment.

Failure to adequately earth the appliance can result in electrical shock causing severe personal injury or death.



WARNING: HAZARDOUS VOLTAGE

Disconnect all power to unit before installing or servicing.

Hazardous voltage can cause severe personal injury or death.



WARNING: ACCESS TO LIVE PARTS

If the supply cables to the appliance are damaged in anyway, they must be immediately replaced by a competent person in order to avoid electrocution which could cause severe personal injury or death.



WARNING

The appliance must be securely fixed to the wall. The installed appliance could weigh up to 165kg and if it falls off the wall it could cause severe personal injury or death. It is the responsibility of the installer to ensure that the appropriate wall fixing is used and that the floor is capable of bearing the full weight.



WARNING

To avoid a fire hazard the cardboard insert within the heater core must be removed before the heater is switched on. Also ensure all polystyrene packaging is removed before the heater is operated. Leaving combustible packaging in the appliance could lead to fire and cause severe personal injury, death and damage to property.



CAUTION

The appliance is very heavy (up to 50kg) and care should be taken when handling during installation to reduce risk of muscular or skeletal injuries.



CAUTION

The appliance should not be repeatedly switched on/off by an external room thermostat as this could lead to failures of the electronic controller and may invalidate the guarantee – further clarification **SHOULD BE SOUGHT FROM THE HELPLINE** on **+44 117 923 5375** or visit <https://heatstore.co.uk/#contact> and complete the online form.



CAUTION

During the first 48 hours of operation rooms must be well ventilated as the heater will produce a smell. Young children, caged birds, or persons with respiratory complaints must not remain in close proximity to the appliance during the first 48 hours of operation.



It is important that the appliance bricks are dry and free from mould growth. Wet or mouldy bricks can lead to an unpleasant odour and or steam being generated by the appliance which could upset the customer and damage the appliance.

Energy Related Product Directive

This product meets the Ecodesign requirements for an electric storage local space heater. Commission Regulation (EU) 2015/1188.

Model Identifier(s):		HSDHHR 050	HSDHHR 070	HSDHHR 100	HSDHHR 125	HSDHHR 150
Heat Output						
Nominal heat output	P _{nom}	0.50kW	0.75kW	1.00kW	1.25kW	1.50kW
Minimum heat output (indicative)	P _{min}	0.00	0.00	0.00	0.00	0.00
Maximum heat output	P _{max,c}	0.90kW	1.20kW	1.50kW	1.70kW	2.00kW
Auxiliary electricity consumption						
At nominal heat output	el _{max}	0.00	0.00	0.00	0.00	0.00
At minimum heat output	el _{min}	0.00	0.00	0.00	0.00	0.00
In standby mode	e _{ISB}	0.000	0.000	0.000	0.000	0.000
Type of Heat input, for electronic storage local space heaters only						
Electronic heat charge control with room temperature feedback				Yes		
Fan assisted heat output				Yes		
Type of heat output / room temperature control						
Electronic room temperature control plus week timer				Yes		

Contact details

Heatstore

Unit 12, Access 18, Bristol, BS11 8HT

Tel: +44 117 923 5375

This product meets the Ecodesign requirements for an electric storage local space heater. Commission Regulation (EU) 2015/1188.

Technical Details

Model Identifier(s):	HSDHHR 050	HSDHHR 070	HSDHHR 100	HSDHHR 125	HSDHHR 150
Input rating +5% / -10%	936/1020W	1435/1560W	2042/2220W	2540/2760W	3024/3300W
Boost Output 230/240V~	312/340W	478/520W	681/740W	847/920W	1008/1100W
Rated Charge Period:	7.7 - 7 Hours	7.7 - 7 Hours	7.7 - 7 Hours	7.7 - 7 Hours	7.7 - 7 Hours
Max Storage Capacity	7.2kWh	10.9kWh	15.4kWh	19.3kWh	23.1kWh
Fan Wattage	11W	11W	11W	11W	11W
UI Wattage	0.5W	0.5W	0.5W	0.5W	0.5W
Sound Level dB (measured in test chamber)	27	29	32	30	31
Energy Cell Packs Required (047243)	4	6	8	10	12
Height (mm)	730	730	730	730	730
Width (mm)	580	703	825	1069	1069
Depth (mm)	185	185	185	185	185

All Models	
Controls	Digitally controlled, Electronic Thermostat accurate to ($\pm 0.2^{\circ}\text{C}$). Timer modes: 7 Day Programmable User Timer, Out All Day, Home All Day Continuous heat modes: Frost Protect Additional Modes: Away, Boost, Setback
Controller UI	<ul style="list-style-type: none"> • Graphical display with RGB backlight • Tactile buttons with audio feedback • User replaceable battery (Coin-Type) • Open window detection, Adaptive Start, Advance Time Period • Wide SP range ($7\text{-}30^{\circ}\text{C}$) • Automatic Charge Control • History / Reporting Screens • Boost Mode, User Adjustable • Heat Demand % Adjustment • Child Lock & Heater Lock (PIN-based)
Safety	Electronic overheat protection. Additional electromechanical overheat protection. LVD and EMC compliance.
IP Rating	IPX4
Battery	3.3V coin cell battery to backup real time clock. Battery life > 5 years.
Supply	1/N/1/N/PE ~230-240V (Twin Supply) 230-240V / 50Hz Class I 1/N/PE ~230-240V (Single Supply) 230-240V / 50Hz Class I
Colour / Finish	Traffic White (RAL 9016), Grille RAL7035
Storage Core	High-density bonded magnetite energy cells
Approvals	UKCA, CE & BEAB
Guarantee	2 Years
Country of Origin	United Kingdom
Manufacturer	Heatstore

Product Clearances

WARNING:

DO NOT PLACE OBJECTS WITHIN 300mm OF THE FRONT OF THE HEATER AND 150mm EITHER SIDE

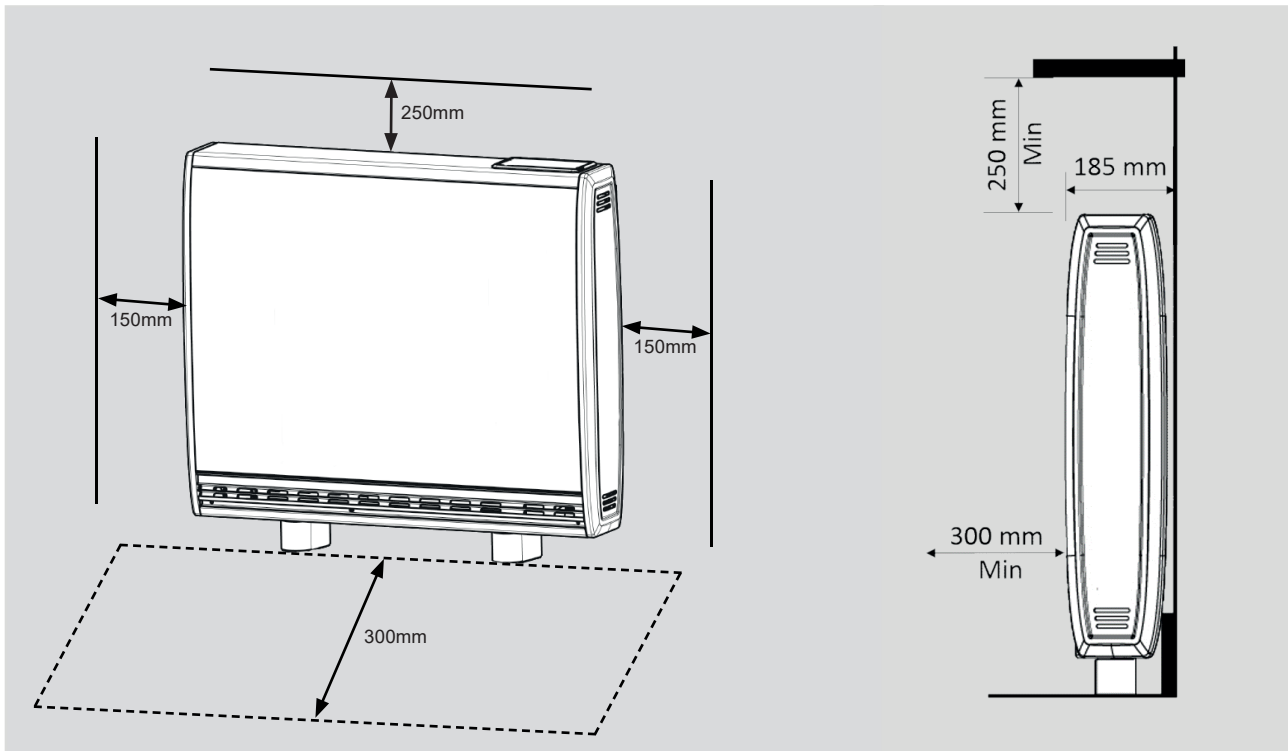

Single Supply

It is important to be aware of how your Dynamic storage heater has been installed electrically. If your heater has only one electrical connection, it must be carefully configured to work with your off-peak electricity tariff.

Available fixed charge times must be manually programmed into the heater to tell it when to charge; no external timers or contactors are needed. Up-to 4 digital charge times can be set.

If charge times are not programmed into the heater, the default times will be used which are set-up by default to support dual-supply installations: 00:00 – 00:00 or 24h charge window.



A 24h charge window in a single supply installation will cause the heater to charge continuously, including times when off-peak electricity is not available, resulting in larger bills.



NOTE:

If electricity tariff charge times have changed, the digital charge times in the heaters settings must be checked to ensure they match.

First Time Power-On

A setup wizard will display when the product is powered on for the first time. This will set the following:

- Time, Date, Daylight Savings Time
- Sound On/Off

For information on using the Heaters controls, refer to page 12. The Heater will then take the User to the Home Screen with the 'Out All Day' Timer Mode active

Important

During initial heat-up, some odour may be emitted due to the newness of materials used in manufacture. This is normal and will disappear after a short period of use. It is however advisable to keep the room well ventilated.

Operation

WARNING: FAILURE TO FOLLOW THESE OPERATING INSTRUCTIONS MAY RESULT IN INJURY AND/OR DAMAGE

The controls are located on the top of the heater consisting of a display screen and three buttons and a Dial.

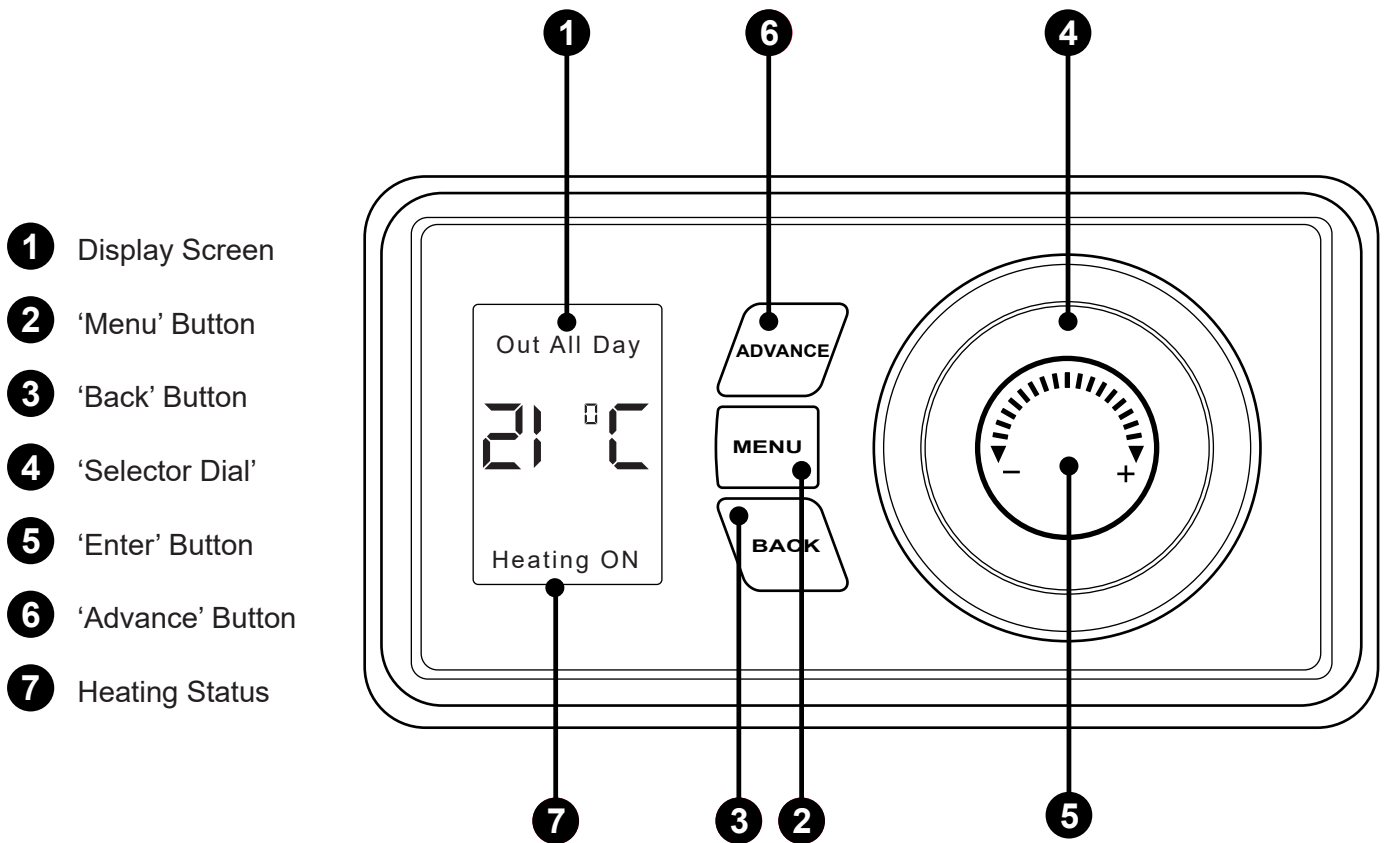

The heater is fitted with an adjustable thermostat enabling the room temperature to be controlled. The minimum room temperature is 7°C. The maximum temperature is set to 30°C by default. A temperature of 21°C is a common comfortable room temperature.



NOTE:

Your heater may produce some noise during operation. This noise is caused by the low noise fan and expansion and contraction of the metalwork as it changes temperature, and is normal for this type of product. Whilst the noise produced is usually very quiet, certain environmental factors can make it more noticeable, such as hard flooring or minimal furnishings.



NOTE:

Should the heater fail to operate, this may be due to the room temperature being higher than the thermostat setting.



NOTE:

If the heater has been turned off at the mains, it may take 2 to 3 days for the heater to acclimatise and reach optimum performance once it receives power again.

The heater controls can be easily adjusted by using the **Dial** and buttons on the User Interface.

1. The Home Screen shows the options available at each stage of adjustment. Here the current target room temperature is displayed along with the mode of operation. Any use of the Advance function will be displayed here, and pressing the **Dial** will show the functions which are enabled.

The currently active mode of operation is displayed at the top of the screen e.g. '**Out All Day**' timer.

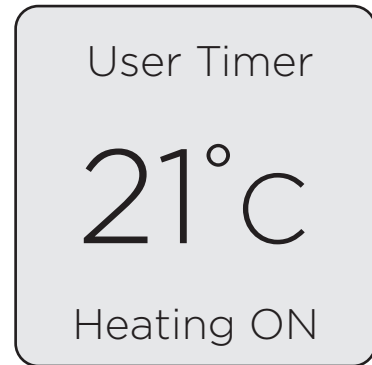

When the heater is in a timer profile and trying to achieve or maintain a room temperature, 'Heating On' will be displayed, otherwise, 'Heating Off' will be displayed. The words 'Heating On / Off' will not be displayed in a manual mode of operation

When the controller buttons have not been pressed for a long period of time, the display will 'sleep' and the text will disappear. The heater is still on and active in whatever Mode it was set to.

2. **Menu** - Displays the Main Menu;
 - Boost – Activate Boost Mode
 - Modes - Set the mode of operation.
 - Settings – Time/Date, Temperature units etc.
3. **Back** returns to the previous screen.
4. Rotate the **Dial** to navigate through the menus and adjust the required room temperature on the main screen. The screen colour changes based on the temperature selected, showing deep blue through to bright red.
5. Press the **Dial** to enter sub menus and to confirm actions.
6. The **Advance** button is only used when a Timer Mode is active, it allows the timer schedule to be changed temporarily by forcing a 'Heating On' period to begin or end early.

Timer Modes

Timer Modes offer the most efficient mode of operation for a predictable heat demand. Additional functions such as Advance and Boost allow the User to make temporary adjustments to timer schedules for a more flexible operation.

Each timer is broken down into 4 definable 'Heating On' time periods and temperatures per day, for each day of the week. Each day consists of a 24-Hour period, starting and finishing at midnight.

When the heater is in a timer profile and trying to achieve or maintain a room temperature, 'Heating On' will be displayed. Otherwise, 'Heating Off' will be displayed.

It is possible to change the Target Temperature of a 'Heating On' period when that period is active. This will temporarily adjust the Target Temperature for just that instance and will not permanently modify the settings for the timer in use.

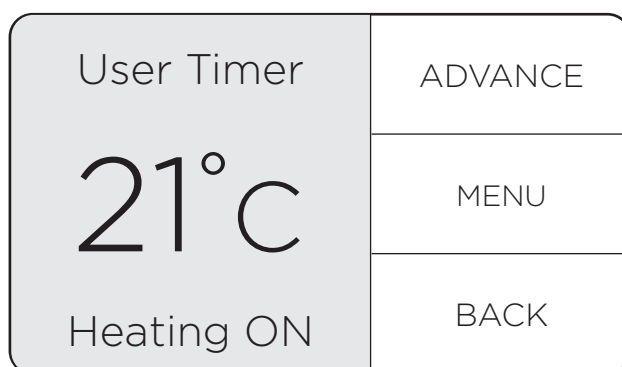

NOTE:

If Adaptive Start is enabled, the heater will maintain the room at the required temperature for the duration of the heating period. To achieve this, the heater will begin heating the room before the start of the heating period to ensure the room is at the required temperature when the period starts.

If Adaptive Start (AS) is disabled, the heater will not operate until the beginning of the heating period. This should be taken into consideration when setting the heating periods.

See page 24 for instruction on enabling/disabling Adaptive Start.

Available Timer Modes

To choose a timer mode, press **Menu** from the home screen. Rotate the **Dial** to highlight 'Modes', then press **Dial** to select. 'Timer Mode' should be highlighted, press the **Dial** to select.

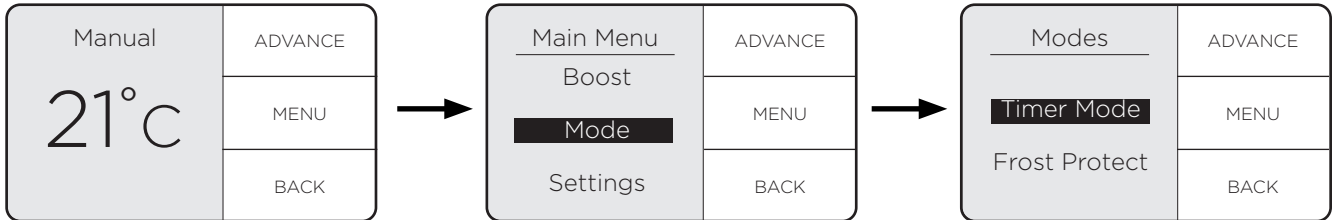

A list of Timer Modes will be shown. Their default settings are shown in the table below.

	Period 1		Period 2		Period 3		Period 4	
User Timer	06:30 – 09:30	21 °C	11:00 – 13:00	21 °C	15:00 – 17:00	21 °C	18:00 – 22:00	21 °C
Home All Day	08:00 – 21:00	21 °C	00:00 – 00:00		00:00 – 00:00		00:00 – 00:00	
Out All Day	07:00 - 8:30	21 °C	17:30 - 22:00	21 °C	00:00 - 00:00		00:00 - 00:00	
Away Mode	Away Mode does not operate in the same way as the other Timers. See section 'Away Mode' on page 17							

Highlight and select one of the available Timer Modes rotating and pressing the **Dial**.

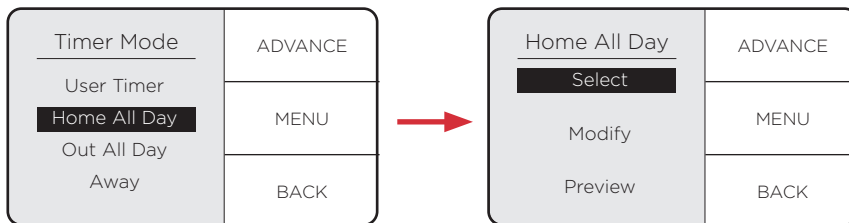

For User Timer, Home All Day and Out All Day, three choices will be available:

- Select - This option will activate the timer
- Modify - This option allows the timer's 'Heating On' times and Target Temperatures to be modified
- Preview - This option displays the timer's configuration. This is handy to quickly check the timer without being able to change any values

Modifying a Timer Mode

Each timer is broken down into 4 definable 'Heating On' periods and temperatures per day.



NOTE:

Once modified a Timer Mode must be selected if you want to begin using it.

When Modify is chosen, 'Heating On' period 1 of 4 for the current day is displayed. The current day will be highlighted. Rotate **dial** to highlight 'Modify', press **dial** to select. The current day will be highlighted.

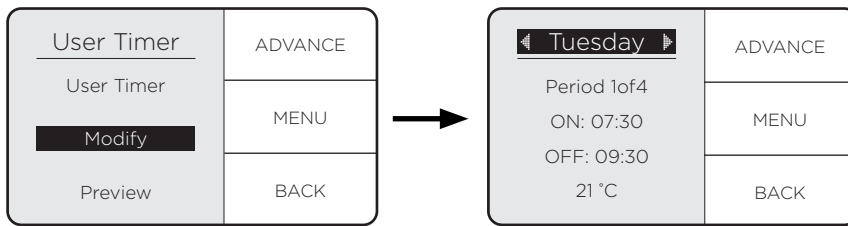

Select and change each option by rotating and pressing the **dial**.

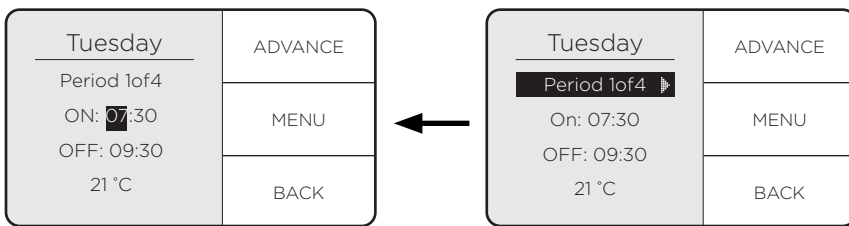

Copy & Paste

To save time when modifying a Timer Mode, the **Advance** button can be used to copy and paste settings. Individual heating periods from one day or every heating period from a day can be copied to another day.

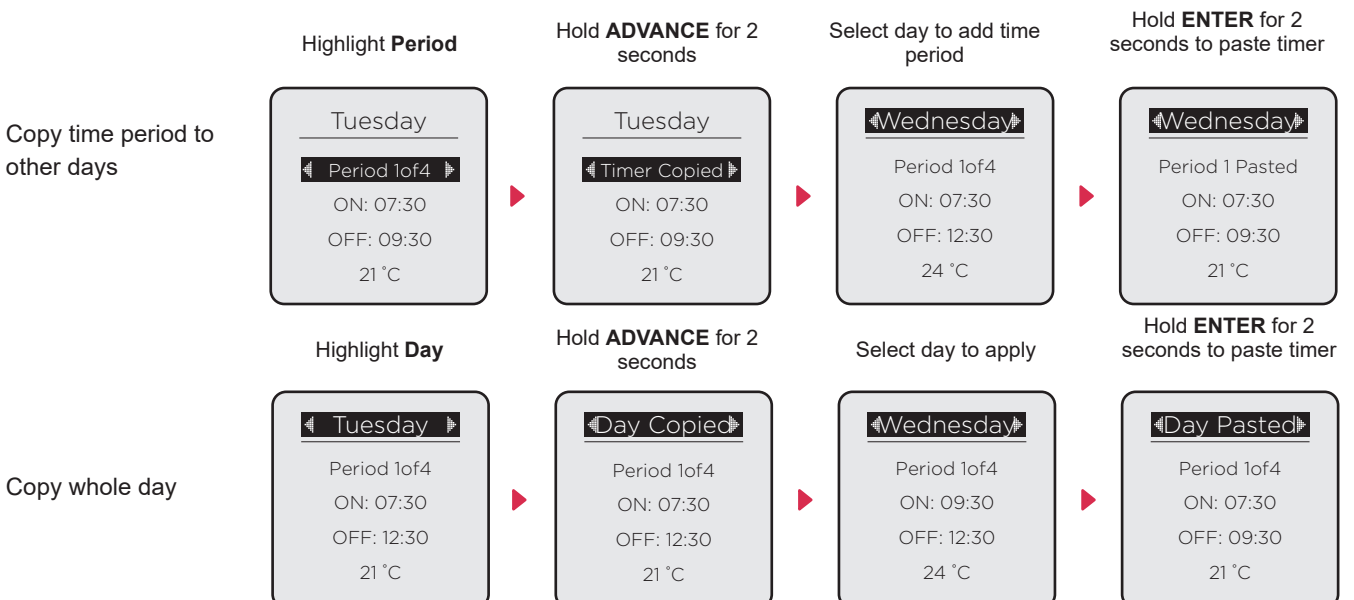

The 'Advance' Function

The **Advance** button is only used when a Timer Mode is active and allows the timer schedule to be changed temporarily. This button allows a 'Heating On' period to begin or end early.

This is useful if you are at home when you had not planned to be, or need to leave when you had planned to have the heating on.

If the heater displays 'Heating Off' and heat is required, press the **Advance** button. If the heater is in 'Heating On' and heat is not required, press the **Advance** button and the heater will stop heating until the beginning of the next 'Heating On' period.

Pre-action State	Action	Impact
Heating On (Timer Mode)	Advance activated	Heating On period switched to Heating Off until next scheduled 'Comfort On' period.
Heating Off (Timer Mode)	Advance activated	Heating Off switched to Heating On until the next scheduled 'Heating Off' period.
Heating On (Advance Active)	Advance Deactivated	Heating On switches to Heating Off. Appliance in following schedule set in the currently active Timer Profile
Heating Off (Advance Active)	Advance Deactivated	Heating Off Switches to Heating On. Appliance in following schedule set in the currently active Timer Profile

Away Mode

Away Mode temporarily overrides the active mode before returning the Heater back to the previously active mode.

This is handy if you are temporarily away at the shops or on holiday and want your heating to resume as normal operation automatically when you return.

While active, Away Mode can maintain a minimum room temperature. By default, this is set to 7 °C (frost protection temperature). This can be modified up to a maximum of 18°C when Away Mode is activated. The heater will also remember the last Away Mode Target Temperature defined while Away Mode is active.

The Away countdown is set in Hours, a Date and a Target Temperature.

The starting Hours and Date show current time and date. Date and Hours are set separately on the heater, making the feature useful for popping out to the shops or going away on holiday.

- The date set is the return date; therefore, Away Mode will end at 23:59 of the day before. E.g. if a return date of 02.02.2018 is set, Away Mode will end at 23:59 on 01.02.2018.
- If hours are set, this will extend away mode end from 23:59 on the day before the date set.
If only hours and no date is set, Away Mode will count from either the current time, or if a date is set.

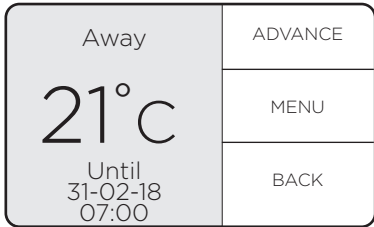
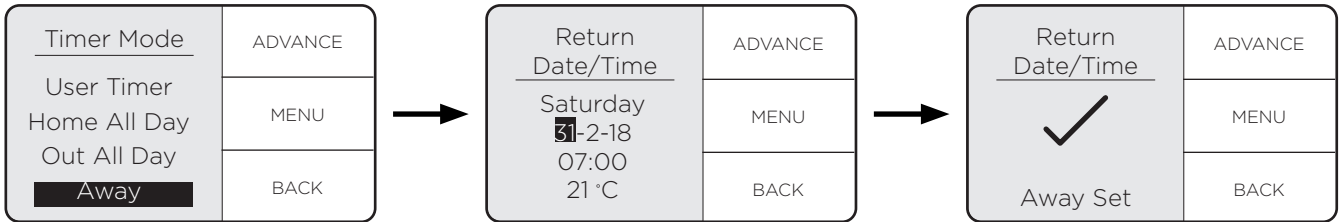

NOTE:
The **Back** button can be used to end the **Away Mode** countdown early.

Frost Protect

This mode maintains a room temperature of 7°C and should be used to provide protection against frost. The Heater will remain in this mode indefinitely until the mode is changed by the User.

To select Frost Protect, rotate **Dial** to highlight 'Frost Protect', press **Dial** to select. Please note, the temperature is not user definable.

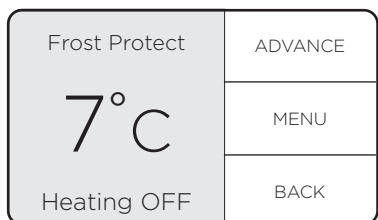
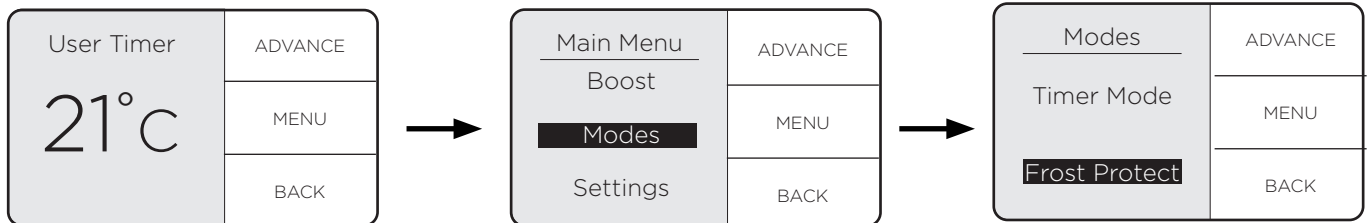

Boost Mode

Boost can be activated at any time, when the product is set to any Timer or Continuous heat mode; even if Advance is active, this mode will provide a temporary 'Boost' of heat. For settings, see Boost settings on page 21.

Boost Mode can be activated from the Home Screen by pressing '**Menu**' to access the Main Menu, then pressing the **Dial** to select 'Boost'. 'Boost' will always be listed as the top item on the list.

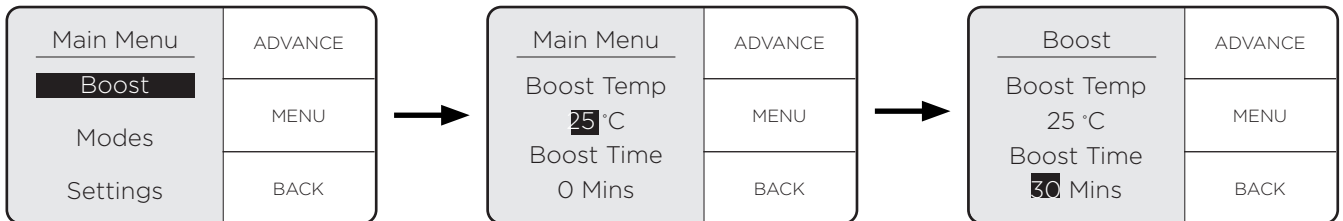

Activating Boost will present two selectable options: Boost Temp (Boost Target Temperature) and Boost Time (Boost Duration Countdown). The default values for these can be set in the Settings Menu.

Rotate and press the **Dial** to modify these values. Pressing **Back** will end Boost early, restoring the heater back to its previously active mode.

- The Boost Temp can be set to any value within the Heater's Target Temperature Range setting.
- The Boost Time can be increased in the following increments: 30 mins, 1 hour, 2 hours, 3 hours, 4 hours. These increments can be restricted with the Max. Boost Duration Range setting. To modify this range, see Boost Settings on page 23.

Once the Boost Duration Countdown has reached 0, the Heater will return to the mode that was active before Boost was activated.



NOTE:

If boost mode is activated and there is not enough stored core energy, peak rate energy will be used unless disabled in heat source settings.

Product Locks

Product Locks are methods of locking the heater's controller to restrict access to functions. This can be activated and configured via the Settings Menu. When Product Lock is activated, the heater continues to run in whichever mode is currently active.

Child Lock

This is the simplest locking method and does not utilise a PIN code. It is toggled on/off on the heater's controller by pressing and holding the **Back** button and the **Dial** for three seconds.

While Child Lock is active, the heater will continue to operate in whatever mode, with whatever settings it had before the lock was activated.

There are no exception rules with this lock, and the user can only choose to unlock the heater if they wish to change the temperature, modes or settings.

Heater Lock (PIN Lock)

Heater Lock is the most customisable and secure lock on the heater. This allows the heater to be configured in any way, then locked into those settings and modes.

When PIN Lock is activated, pressing the **Menu** button will show one item* that can be selected - 'Unlock'. Selecting 'Unlock' prompts the User to complete the applicable Unlock action:

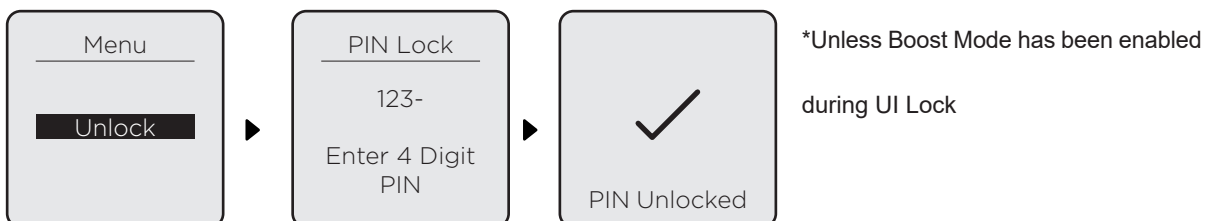

PIN Lock Exceptions

It is possible to allow the 'Advance' and 'Boost' functions to be enabled/disabled when PIN Lock is active.

There are up to 4 exceptions. These exceptions include:

- Advance

- Ability to activate using the 'Advance Button'

- Boost

- Ability to activate using the 'hotkey' listed in the Main Menu
- Ability to modify the Boost Temperature
- Ability to modify the Boost Duration

'Advance Function' Operation during PIN Lock

If Advance has been enabled during PIN Lock, the Advance button will remain active when PIN Lock is active. This will function in the same way it would if the controls were not locked: only if the Heater is Locked into a Timer Mode.

- If Advance is enabled during UI lock, the **Advance** button will function as normal while the Heater is set to a Timer Mode.
- If Advance is Disabled during UI lock, the **Advance** button will not function.

'Boost Function' Operation during PIN Lock

If enabled, Boost will function in the same way as it does when PIN Lock is not active unless modification of Boost Temperature and Boost Duration have been disabled.

Boost Temperature and Boost Duration will be set to the default values when 'Boost' is activated. If either of these values have been disabled during Product lock, when the user tries to modify them the heater's display will show the message 'Disabled' and only the default value can be used. The default values can be changed outside of PIN Lock.

Settings

To navigate to the Settings Menu, from the Home Screen:

Press the **Menu** button to access the Main Menu. Rotate the **Dial** to highlight 'Settings', then press the **Dial**. Each of the following headings relate to an item in the Settings Menu.

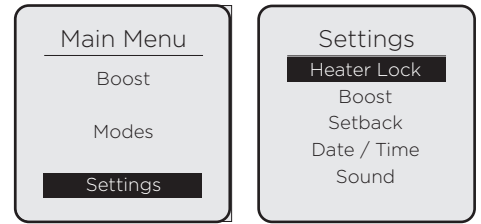

Heater Lock

Set Lock

Heater (PIN) Lock can be enabled here by highlighting 'Heater Lock' and pressing the **Dial** to enter the Heater Lock menu. Highlight 'Set Lock', press the **Dial**, enter a 4-digit PIN code, then pressing the **Dial** to lock the heater.

Lock Settings

Before PIN Lock is enabled, the User can select 'Lock Settings' to enable/disable the Advance and/or Boost functions, as well as enable/disable modification of the Boost Temperature and Boost Duration. See below.

Boost Lock

Three settings can be modified within this Menu:

- **Enable / Disable** - The 'Boost' Menu Item can be Enabled/Disabled while PIN Lock is active.
- **Temperature Rule** - Modifiable Boost Temperature while PIN Lock is active
 - **Enable** – While Boost is active, the User can modify this value as they normally would
 - **Disable** – Default value will be loaded. When the user tries to modify the value, the UI will show the following text: 'Disabled'.
- **Duration Rule** - Modifiable Boost Duration while PIN Lock is active.
 - **Enable** – While Boost is active, the User can modify this value as they normally would
 - **Disable** – Default value will be loaded. When the user tries to modify the value, the UI will show the following text: 'Disabled'

Advance Lock

- **Enable / Disable** - This setting allows the User to Enable or Disable the **Advance** button while PIN Lock is active.

Boost Settings

Default Boost Target Temperature

This is the default Boost Target Temperature that is used when 'Boost Mode' is activated.

Max Boost Duration

This is the maximum length of time that the user is able to activate 'Boost' for. Shown in minutes (when under an hour) or hours (if over an hour) in the following increments: 30 mins, 1 hour, 2 hours, 3 hours, 4 hours.

The value chosen will be the max allowed when boost is activated. This is required for the Boost Duration Lock to function.

Setback Settings

Setback is a function that only modifies Timer Mode operation. When Setback is enabled it overrides any 'Heating Off' period to maintain a constant temperature.

This can be used to prevent the room temperature from falling below a minimum value while there is no demand for heat ('Heating Off').

The value of this temperature is restricted to a value between 8 and 19 °C. This is because Setback should not be treated as a regular 'Heating On' period.

Date & Time Settings

This allows the Time, Date and Daylight Savings Time settings to be modified.

Sound Settings

Audio feedback when the user presses a button can be enabled or disabled here.

Adaptive Settings

Open Window Detection

This is a global setting that can interrupt any active mode. Activating this setting enables Open Window Detection to switch the Heater to a 'Heating OFF' state if it detects an open window in the room it's operating in.

Adaptive Start

Adaptive Start is predictive function that only modifies Timer Mode operation. This function models the heating characteristics of the room and uses that information to pre-heat the room for only the time required to achieve the Target Temperature by the start of the 'Heating On' period.

For example, with Adaptive Start off, the 'Heating On' time is the time that the Heater will begin to try and achieve the Target Temperature. With Adaptive Start On, the Heater will begin to heat the room before the User-defined 'Heating On' time so that the Target Temperature is achieved when the User defined the 'Heating On' start time.



NOTE: Adaptive Start

This is a continuously learning function and will be affected daily by changes in the heater's environment. The heater will take into account the starting temperature of the room so pre-heating should remain accurate.

It is important that if multiple heaters are installed in one room that all heaters have the Adaptive Start (AS) function enabled. If this is not the case, heaters with AS enabled will pre-heat the room to the desired target temperature before the heaters with AS disabled attempt to output heat.

It is likely that if two heaters are required in one room, that the output from one heater may not be sufficient to heat the room alone. This may cause the pre-heat time calculation to extend to a large degree if the heaters do not all have AS enabled. This may lead to heat at unwanted times and excessive wear to some heaters.

A two-hour limit is enforced on the calculation, however, if all heaters have AS enabled and pre-heating takes over one-hour, extreme environmental factors may be affecting the calculation or the heaters may be under sized for the room. Please contact us for support if your pre-heat time seems excessive.



NOTE: Open Window Detection

In environments where the product may read sudden decreases in temperature, this feature may activate in error. This can occur in drafty or poorly insulated environments as well as if the heater is undersized for the room. This feature should be disabled using the instructions above if activating for reasons other than the intended purpose. If you think that your environment is not as described here and this feature is activating, please contact our customer care team with the details on the rear page of this document.

Error Codes

Error codes are to be defined as a list. Each error code must be defined as a perimeter that Central Control can read.

Fault Code	Description
20	Component thermistor hardware fault
20	
21	
22	
23	
24	
30	Component overheat
32	
33	
34	
40	Internal serial comms error
41	Heating element fault
50	Open window detected
52	Heat output disabled
53	Time loss error
55	Unknown error

Battery Replacement

IMPORTANT:

Before replacing the battery ensure the heater is isolated from the electricity supply.



NOTE:

Battery should be disposed of in an appropriate manner

This product is fitted with a replaceable battery in the controls. To replace the battery, follow the steps below:

1. Push a small flat headed screwdriver into the opening on the right hand side of the User Interface (Fig. 1) to release the clip.
2. Lift the User Interface module out away from the heater being careful not to damage the cable
3. Unscrew the battery cover (Fig. 2) to gain access to the battery holder.
4. Use a small flat headed screwdriver to remove the battery from the battery holder and replace the battery.
5. Replace the battery access cover.
6. Push the User Interface module back into place, again avoiding damage to the cable.

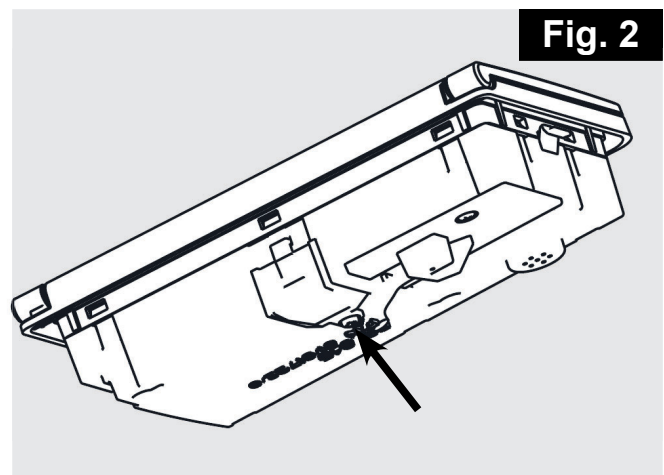
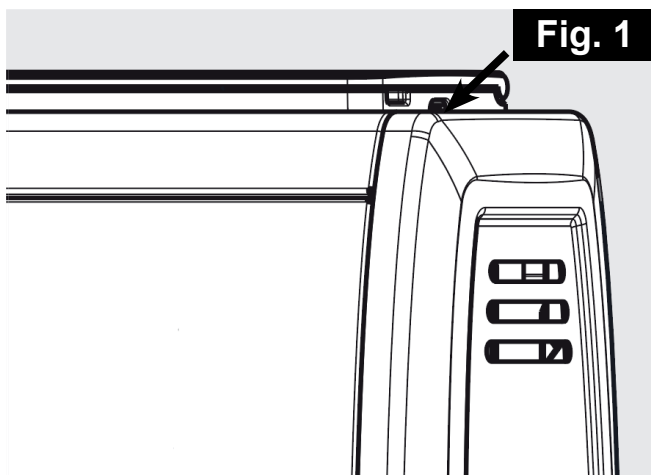

Important

During the initial operation, some odour may be noticed due to the newness of materials used in manufacture. This is normal and will disappear after a short period of use. It is however advisable to keep the room well ventilated

Cleaning

WARNING - ALWAYS DISCONNECT FROM THE POWER SUPPLY BEFORE CLEANING THE HEATER.

Before commencing cleaning, isolate the heater from the electrical supply and allow it to cool. The outside can be cleaned by wiping it over with a soft dry cloth. Do not use abrasive cleaning powders or furniture polish, as this can damage the surface finish.

Guarantee

What does a Heatstore Guarantee cover?

Heatstore products deliver reliable service for use in dwellings. All Heatstore products are individually tested before leaving the factory.

If you are a consumer and you experience a problem with your Heatstore product, which is found to be defective due to faulty materials or workmanship within the Guarantee Period, this Heatstore Guarantee will cover repair or - at the discretion of Heatstore – replacement with a functionally equivalent Heatstore product.

The Heatstore Guarantee Period is two calendar years from the date of purchase of your Heatstore product, or the date of delivery of the product, if later. The Heatstore Guarantee is conditional upon you providing the original purchase receipt as proof of purchase. Please therefore retain your receipt as proof of purchase.

If you do experience a problem with your Heatstore product please call the Helpline on **+44 117 923 5375** or visit <https://heatstore.co.uk/#contact> and complete the online form. We will need details of your Heatstore product, its serial number and a description of the fault which has occurred. You can find the model number and serial number for your Heatstore product on the heaters' side. Once we receive your information and proof of purchase we will contact you to make the necessary arrangements.

If your Heatstore product is not covered by this Heatstore Guarantee there may be a charge to repair your product. However, we will contact you for agreement to any charges before any chargeable service is carried out.

What is not covered by a Heatstore Guarantee?

The Heatstore Guarantee does not cover any of the following:

- Any fault or damage to your Heatstore product due to faulty materials or workmanship occurring outside the two year Guarantee Period.
- Any fault or damage occurring to any pre-owned Heatstore product or to any other equipment or property.
- Accidental damage to your Heatstore product or damage to your Heatstore product from external sources (for example, transit, weather, electrical outages or power surges).
- Fault or damage to your Heatstore product which is:
- Not due to faulty materials or workmanship or which is due to circumstances outside Heatstore's control.
- Caused by use of your Heatstore product for anything other than normal dwelling usage in the country where it was purchased.
- Caused by any misuse, abuse or negligent use of the Heatstore product, including but not limited to any failure to use it in accordance with the Installation Instructions supplied with the product.
- Caused by any failure to assemble, install, clean and maintain your Heatstore product in accordance with the Operating Instructions supplied with the product unless this was carried out by Heatstore or its authorised dealers.
- Caused by repairs or alterations to your Heatstore product not carried out by Heatstore service personnel or its authorised dealer(s).
- Caused by use of any consumables or spare parts for your Heatstore product which are not Heatstore specified.

Terms and Conditions

- The Heatstore Guarantee is valid for Heatstore from the date of purchase of your Heatstore product from a recognised retailer in the country of purchase and use, or the date of delivery of the product if later, always provided the original receipt has been retained and is produced as proof of purchase.
- You must provide to Heatstore or its authorised agents on request the original receipt as proof of purchase and - if required by Heatstore - proof of delivery. If you are unable to provide this documentation, you will be required to pay for any repair work required.
- Any repair work under the Heatstore Guarantee will be carried out by Heatstore or its authorised dealer(s) and any parts that are replaced will become the property of Heatstore. Any repairs performed under the Heatstore Guarantee will not extend the Guarantee Period.
- Any replacement of your Heatstore product by Heatstore during the Guarantee Period will not start the Guarantee period afresh.
- The Heatstore Guarantee does not entitle you to recovery of any indirect or consequential loss or damage including but not limited to loss or damage to any other property.
- The Heatstore Guarantee is in addition to your statutory rights as a consumer and your statutory rights are not affected by this Heatstore Guarantee.

If you have any questions about what the Heatstore Guarantee covers and does not cover or how to claim under the Heatstore Guarantee, please contact us using the information on the back page.

Contact details

Heatstore, Unit 12, Access 18, Bristol, BS11 8HT



Important

For electrical products sold within the European Community. At the end of the electrical products useful life it should not be disposed of with household waste. Please recycle where facilities exist. Check with a Local Authority or retailer for recycling advice in your country. Batteries should be disposed of or recycled in accordance with WEEE Directive 2012/19/EU. Packaging should be recycled where possible.

Products within the Dynamic HHR Storage Heater range are protected by one or more of the following patents:

Great Britain: GB2481048, GB2487147, GB2487148, GB2487781, GB2500736, GB2511538, GB2526552

International: EP2830832, EP2831688, EP2965166, EP3132324, WO2011154521, WO2013144170, WO2014135667, WO2015181136



Tel: +44 117 923 5375
enquiries@heatstore.co.uk

Heatstore
Unit 12, Access 18, Bristol, BS11 8HT

Heatstore. A91 KA9R, IR



© Heatstore. All rights reserved.