

# SI Solar Isolators

## TRUE DC Isolators for PV Systems



- Market-leading design
- 2, 4, 6 & 8 pole versions available
- Max. rated current 85A@1000VDC (acc. to DC21B/DC-PV1 for SI55)
- Range of mounting options
- Guaranteed arc suppression (3ms typical)
- Operator independent switching mechanism
- Knife-edge contacts



### Innovators in TRUE DC isolation

Since its launch, the SI range of TRUE DC isolators has set the benchmark safety standard for disconnection and isolation of the DC panel load in solar applications world-wide. Prior to the introduction of the SI series, AC modified isolators in multi-pole linked form were commonly used with all the performance and safety issues that such devices presented.

The SI TRUE DC range was specifically developed to meet the needs of the solar industry with full operator independent switching mechanism, a guaranteed 5ms maximum arc suppression time and long-life knife edge contacts. Arc chambers built-in to the unit keep the device cool under repeated operation and the full range of mounting options provide a solution for almost every application.

Adopted as the standard by many of the largest solar equipment designers and installers around the world, the SI Series continues to set the benchmark in solar safety.

### Additional Resources

There is only so much you can illustrate in printed form, so we have included a QR code which will take you directly to the Featured Spotlight for TRUE DC isolators on the IMO website. Here you will be able to watch a couple of videos about solar safety and recommendations from the Institution of Engineering & Technology in conjunction with the BRE National Solar Centre, about raising the bar for quality in the solar PV industry.



# Ordering Variations

## Lever Handle Models

Panel Mount (4-screw) 64 x 64 Escutcheon Plate Lever Handle, IP66, NEMA 3R	Single Hole Mount (22.5mm) 48 x 48 Escutcheon Plate Lever Handle, IP66, NEMA 4X	Base Mount (door coupling) 64 x 64 Escutcheon Plate Lever Handle, IP66, NEMA 4X	Modular Switch Lever Handle, IP40, Open Type
<b>SI**PM64*</b>	<b>SI**SHM*</b>	<b>SI**BMD64*</b>	<b>SI**DB*</b>

## Lever Handle Models with Lockable OFF

Panel Mount (4-screw) 64 x 64 Escutcheon Plate Lockable Lever Handle, IP66, NEMA 3R	Single Hole Mount (22.5mm) 48 x 48 Escutcheon Plate Lockable Lever Handle, IP66, NEMA 4X	Base Mount (door coupling) 64 x 64 Escutcheon Plate Lockable Lever Handle, IP66, NEMA 4X	Modular Switch Lockable Lever Handle, IP40, Open Type
<b>SI**PML64*</b>	<b>SI**SHML*</b>	<b>SI**BMDCL64*</b>	<b>SI**DBL*</b>

## Rotary Handle Models with Lockable OFF

Panel Mount (4-screw) 64 x 64 Lockable Rotary Handle, IP66, NEMA 3R	Base Mount (door coupling) 64 x 64 Lockable Rotary Handle, IP66, NEMA 4X	Enclosed Version Lockable Rotary Handle, IP67, NEMA 4X
<b>SI**PM64R*</b>	<b>SI**BMD64R*</b>	<b>SI**PEL64R*</b>

**NOTE:**

For description of each mounting mechanism please refer to pages 27 - 30.  
IP ratings are for front panel and enclosed.

## Part Number Configuration

<b>SI</b>		<b>16</b>	<b>-</b>	<b>PM64R</b>	<b>-</b>	<b>2</b>
<b>Series</b>						<b>Number of Poles (see Switching Configurations on p.5)</b>
SI DC Solar Isolator						<b>2</b> 2-Pole
<b>Switch Rating</b>						<b>2H</b> 2-Pole 4 Parallel Poles
16 Amp	<b>16</b>	40 Amp	<b>40</b>			<b>4</b> 4-Pole
25 Amp	<b>25</b>	55 Amp	<b>55</b>			<b>4S</b> 2-Pole 4 Poles in Series (Input Top, Output bottom)
32 Amp	<b>32</b>	65 Amp	<b>65</b>			<b>4T</b> 2-Pole 4 Poles in Series (Input & Output bottom)
38 Amp	<b>38</b>					<b>4B</b> 2-Pole 4 Poles in Series (Input & Output top)
<b>Mounting Type</b>						<b>6</b> 6-Pole
Panel Mount (4-screw), 64 x 64 Escutcheon Plate, Lever Handle						<b>3H</b> 2-Pole 6 Parallel Poles
						<b>8</b> 8-Pole
Panel Mount (4-screw), 64 x 64 Escutcheon Plate, Lockable Lever Handle						<b>4H</b> 2-Pole 8 Parallel Poles
Panel Mount (4-screw), 64 x 64 Lockable Rotary Handle						
Single Hole (22.5mm) Mount, 48 x 48 Escutcheon Plate, Lever Handle						
Single Hole (22.5mm) Mount, 48 x 48 Escutcheon Plate, Lockable Lever Handle						
Base Mount (DIN Rail), 64 x 64 Escutcheon Plate, Lever Handle						
Base Mount (DIN Rail), 64 x 64 Escutcheon Plate, Lockable Lever Handle						
						Base Mount (DIN Rail), 64 x 64 Lockable Rotary Handle
						Modular Switch, Lever Handle
						Modular Switch, Lockable Lever Handle
						Enclosed Version, Lockable Rotary Handle

# Switching Configurations

Type	2-pole	2-pole 4 parallel poles	4-pole	4 poles in series Input on top Output bottom	4 poles in series Input and Output bottom	4 poles in series Input and Output on top
SI16	2	2H	4	4S	4T	4B
SI25	2	2H	4	4S	4T	4B
SI32	2	2H	4	4S	4T	4B
SI38	2	2H	4	4S	4T	4B
SI40	2	2H	4	4S	4T	4B
SI55	2	2H	4	4S	4T	4B
SI65	2	2H	4	4S	4T	4B
Contact Wiring Diagram						
Switching Example						

Type	6-pole	2-pole 6 parallel poles	8-pole	2-pole 8 parallel poles
SI16	6	3H	8	4H
SI25	6	3H	8	4H
SI32	6	3H	8	4H
SI38	6	3H	8	4H
SI40	6	3H	8	4H
SI55	6	3H	8	4H
SI65	6	3H	8	4H
Contacts Wiring Diagram				
Switching example				

## Insulated Jumper for series and parallel switching of contacts

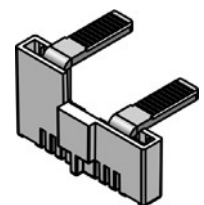

Type	SI16	SI25	SI32	SI38	SI40	SI55	SI65	
4T / 4B / 4S		2x SIV-B1-1N		2x SIV-B1-2N		2x SIV-B2-2N		
2H		4x SIV-B1-1N				4x SIV-B2-1N		
4H		8x SIV-B1-1N, 2x SIV-B1-2N			8x SIV-B2-1N, 2x SIV-B2-2N			



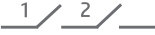
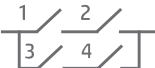

SIV-B1-1N

**WARNING:** Verify that all connections (including bridging link connections) are suitable for the rated current, prepared to ensure only conductive parts are clamped and tightened to the manufacturer's required torque before energisation.

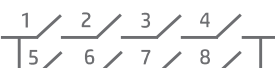
## Technical Data for DC according to IEC 60947-3



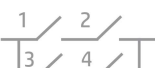



Type		DC-PV1							DC22B				
		500V	600V	700V	800V	900V	1000V	1200V	1500V	500V	600V	800V	1000V
2 poles in series 2 	<b>SI16</b>	16A	16A	16A	16A	16A	10A	7A	3A	7A	5.5A	2A	1A
	<b>SI25</b>	25A	25A	25A	20A	17A	11.5A	8.5A	5A	8A	6A	2.5A	1.5A
	<b>SI32</b>	32A	32A	32A	23A	20A	13A	10A	6A	9A	6.5A	3A	2A
	<b>SI38</b>	45A	45A	36A	30A	25A	20A	10A	6A				
	<b>SI40</b>	48A	48A	37A	35A	31A	29A	11A	7.5A				
	<b>SI55</b>	55A	55A	55A	55A	43A	36A	17A	10A				
	<b>SI65</b>	75A	75A	75A	65A	55A	40A	17A	10A				
2 poles in series + 2 parallel 2H 	<b>SI16</b>	29A	29A	22A	17A	16A	10A	7A	3A				
	<b>SI25</b>	45A	45A	27A	20A	17A	11.5A	8.5A	5A				
	<b>SI32</b>	58A	55A	32A	23A	20A	13A	10A	6A				
	<b>SI38</b>	65A	58A	36A	30A	25A	20A	10A	6A				
	<b>SI40</b>	72A	68A	49A	42A	31A	29A	11A	8A				
	<b>SI55</b>	85A	85A	77A	63A	43A	36A	17A	10A				
	<b>SI65</b>	85A	85A	80A	65A	55A	40A	17A	10A				
4 poles in series 4S, 4B, 4T 	<b>SI16</b>	16A	16A	16A	16A	16A	16A	16A	16A	16A	16A	11.5A	8A
	<b>SI25</b>	25A	25A	25A	25A	25A	25A	25A	25A	25A	25A	12A	9A
	<b>SI32</b>	32A	32A	32A	32A	32A	32A	32A	32A	32A	32A	12.5A	10A
	<b>SI38</b>	45A	45A	45A	45A	45A	38A	32A	32A				
	<b>SI40</b>	48A	48A	48A	48A	48A	40A	40A	40A				
	<b>SI55</b>	55A	55A	55A	55A	55A	55A	55A	55A				
	<b>SI65</b>	75A	75A	75A	75A	75A	75A	65A	65A				
4 poles in series + 2 parallel 4H 	<b>SI16</b>	29A	29A	29A	29A	29A	29A	29A	20A				
	<b>SI25</b>	45A	45A	45A	45A	45A	45A	33A	26A				
	<b>SI32</b>	58A	58A	58A	58A	58A	58A	50A	32A				
	<b>SI38</b>	65A	65A	65A	65A	65A	65A	50A	32A				
	<b>SI40</b>	72A	72A	72A	72A	72A	72A	56A	42A				
	<b>SI55</b>	85A	85A	85A	85A	85A	85A	65A	55A				
	<b>SI65</b>	85A	85A	85A	85A	85A	85A	65A	55A				

## Technical Data for DC according to UL508i

Type		UL508i						
		350V	500V	600V	700V	800V	900V	1000V
2 poles in series 2 	<b>SI16</b>	16A	16A	16A				
	<b>SI25</b>	25A	25A	25A				
	<b>SI32</b>	32A	32A	32A				
	<b>SI38</b>	45A	45A	45A				
	<b>SI40</b>	48A	48A	48A	32A	26A	20A	16A
	<b>SI55</b>	55A	55A	55A	46A	37A	28A	20A
	<b>SI65</b>	65A	65A	65A	50A	40A	32A	25A
2 poles in series + 2 parallel 2H 	<b>SI16</b>	29A	29A	21A				
	<b>SI25</b>	45A	41A	30A				
	<b>SI32</b>	58A	43A	33A				
	<b>SI38</b>	58A	45A	36A				
	<b>SI40</b>	72A	53A	42A	35A	30A	26A	22A
	<b>SI55</b>	85A	66A	55A	47A	40A	32A	25A
	<b>SI65</b>	85A	73A	65A	50A	40A	32A	23A
4 poles in series 4S, 4H, 4T 	<b>SI16</b>	16A	16A	16A				
	<b>SI25</b>	25A	25A	25A				
	<b>SI32</b>	32A	32A	32A				
	<b>SI38</b>	45A	45A	36A				
	<b>SI40</b>	48A	48A	40A	40A	40A	40A	40A
	<b>SI55</b>	55A	55A	55A	55A	55A	55A	55A
	<b>SI65</b>	65A	65A	65A	65A	65A	65A	65A
4 poles in series + 2 parallel 4H 	<b>SI16</b>	29A	29A	29A				
	<b>SI25</b>	45A	45A	45A				
	<b>SI32</b>	58A	58A	50A				
	<b>SI38</b>	58A	58A	50A				
	<b>SI40</b>	80A	71A	65A	58A	51A	45A	42A
	<b>SI55</b>	85A	85A	85A	76A	71A	67A	64A
	<b>SI65</b>	85A	85A	85A	85A	76A	73A	70A

# Technical Data

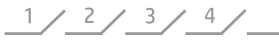
Data according to IEC 60947-3, VDE 0660, GB14048.3

Main Contacts		Type	SI16	SI25	SI32	SI38	SI40	SI40	SI55						
Rated thermal current $I_{the}$		A	16	25	32	45	48	48	55						
Rated insulation voltage $U_L^{1)}$		V	1000	1000	1000	1000	1500	1500	1500						
Rated insulation voltage $U_L^{2)}$		V	1500	1500	1500	1500	1500	1500	1500						
Distance of contacts (per pole)		mm	8	8	8	8	8	8	8						
<b>Rated operational current <math>I_e</math></b>															
<b>DC21A &amp; DC21B</b>	1 pole 1 	300V	A	16	23	27	27	40	55						
		400V	A	12	14	14	16	25	30	33	40	44			
		500V	A	9	10	11	17	13	20	19	24	25	32		
		600V	A	6	7	8	12	10	15	15	19	20	25		
		700V	A	4.5	5	6		7.5		10	12	15	18		
		800V	A	3		4		5		8	10	10	13		
		900V	A	2.5	3	3		4		6	8	8	10		
		1000V	A	1.5	2	2		2.5	3	4	5	6	8		
		<b>DC21B</b>	2 poles in series 2 	500V	A	16	25	32		45	48	55			
				600V	A	16	25	32		45	48	55			
700V	A			16	23	25	27	32	36	35	37	55			
800V	A			16	16	20		23		30	35	45	55		
900V	A			13	16	16	17	20		25	25	31	35	43	
1000V	A			9	10	11	11.5	13		20	25	29	36		
1200V	A			6	7	8	8.5	10		10	11	15	17		
1500V	A			3		4	5	5	6	6	6	7.5	7.5	10	
2 poles in series + 2 poles parallel 2H 	500V			A	29	45	58			65	72	85			
	600V			A	29	45	50	55		64	68	80	85		
	700V			A	16	22	23	27	32		35	49	55	77	
	800V			A	16	17	20		23		30	35	42	45	63
	900V			A	13	16	16	17	20		25	31	35	43	
	1000V			A	9	10	11	11.5	13		20	23	29	25	36
	1200V			A	6	7	8	8.5	10		10	11	15	17	
3 poles in series + 2 poles parallel 3H 	500V	A	29	45	58			72	85						
	600V	A	29	45	50	58		72	85						
	700V	A	29	38	43	45	55		72	85					
	800V	A	29	38	40		51		68	85					
	900V	A	29		38		47		62	78					
	1000V	A	29		38		45		58	70					
	1200V	A	12		14	25	16	28							
4 poles in series 4S, 4B, 4T 	500V	A	16	25	32			45	48	55					
	600V	A	16	25	32			45	48	55					
	700V	A	16	25	32			40	55						
	800V	A	16	25	32			40	55						
	900V	A	16	25	32			40	55						
	1000V	A	16	25	32			38	40	55					
	1200V	A	16	25	32			40	55						
4 poles in series + 2 poles parallel 4H 	500V	A	29	45	58			65	72	85					
	600V	A	29	45	58			72	85						
	700V	A	29	45		58		72	85						
	800V	A	29	45		58		72	85						
	900V	A	29	45		58		72	85						
	1000V	A	29		45		58	65	72	85					
	1200V	A	29		45	50	32	50	56	65					
1500V	A	16		20	26	23	32	32	42	55					
<b>Rated operational current <math>I_e</math></b>															
AC21B	2, 4	$U_e$ max. 440V	A	16	25	32	45	48	55						
	2H	$U_e$ max. 440V	A	29	45	58		72	85						

1) Suitable at overvoltage category I to III, pollution degree 3 (standard-industry):  $U_{imp} = 8kV$ .

2) Suitable at overvoltage category I to III, pollution degree 2 (min.IP55):  $U_{imp} = 8kV$ .

# Technical Data continued

Data according to IEC 60947-3, VDE 0660, GB14048.3

Main Contacts	Type	SI16	SI25	SI32	SI38	SI40	SI55	SI65	
<b>Rated operational current I<sub>e</sub></b> 1 pole 1	300V	A	16	23	27	27	40	65	
	400V	A	14	22	25	25	33	50	
	500V	A	10	17	20	20	24	40	
	600V	A	7	12	15	15	19	30	
	700V	A	5	6	7.5	7.5	12	21	
	800V	A	3	4	5	5	10	15	
	900V	A	3	3	4	4	8	10	
	1000V	A	2	2	3	3	5	8	
	2 poles in series 2	500V	A	16	25	32	45	48	75
		600V	A	16	25	32	45	48	75
700V		A	16	25	32	36	37	75	
800V		A	16	20	23	30	35	65	
900V		A	16	17	20	25	31	55	
1000V		A	10	11.5	13	20	29	40	
1100V		A	8	10	11.5	-	19	25	
1200V		A	7	8.5	10	10	11	17	
1300V		A	6	7	8	-	10	14	
1400V		A	5	6	7	-	9	12	
2 poles in series + 2 poles parallel 2H	500V	A	29	45	58	65	72	85	
	600V	A	29	45	55	58	68	85	
	700V	A	22	27	32	36	49	80	
	800V	A	17	20	23	30	42	63	
	900V	A	16	17	20	25	31	43	
	1000V	A	10	11.5	13	20	29	36	
	1100V	A	8	10	11.5	-	19	25	
	1200V	A	7	8.5	10	10	11	17	
	1300V	A	6	7	8	-	10	14	
	1400V	A	5	6	7	-	9	12	
3 poles in series + 2 poles parallel 3H	500V	A	29	45	58	-	72	85	
	600V	A	29	45	58	-	72	85	
	700V	A	29	43	55	-	72	85	
	800V	A	29	40	51	-	68	85	
	900V	A	29	38	47	-	62	78	
	1000V	A	29	38	45	-	58	70	
	1100V	A	19	27	37	-	-	-	
	1200V	A	17	25	28	-	-	-	
	1300V	A	15	21	25	-	-	-	
	1400V	A	12	18	22	-	-	-	
4 poles in series 4S, 4B, 4T	500V	A	16	25	32	45	48	55	
	600V	A	16	25	32	45	48	55	
	700V	A	16	25	32	45	48	55	
	800V	A	16	25	32	45	48	55	
	900V	A	16	25	32	45	48	55	
	1000V	A	16	25	32	38	40	55	
	1100V	A	16	25	32	-	40	55	
	1200V	A	16	25	32	32	40	55	
	1300V	A	16	25	32	-	40	55	
	1400V	A	16	25	32	-	40	55	
4 poles in series + 2 poles parallel 4H	500V	A	29	45	58	65	72	85	
	600V	A	29	45	58	65	72	85	
	700V	A	29	45	58	65	72	85	
	800V	A	29	45	58	65	72	85	
	900V	A	29	45	58	65	72	85	
	1000V	A	29	45	58	65	72	85	
	1100V	A	29	45	54	-	60	68	
	1200V	A	29	45	50	50	56	65	
	1300V	A	26	39	44	-	50	61	
	1400V	A	23	33	38	-	46	-	
1500V	A	20	26	32	32	42	55		



# Technical Data continued

Data according to IEC 60947-3, VDE 0660, GB14048.3

Main Contacts	Type	SI16	SI25	SI32	SI38	SI40	SI55	SI65		
<b>Rated operational current I<sub>e</sub></b> 1 pole 1	300V	A	16	23	27	27	40	55	-	
	400V	A	14	18	20	20	30	40	-	
	500V	A	10	12	14	14	19	25	-	
	600V	A	5	6	8	8	10	13	-	
	700V	A	1.5	2	3	3	7	10	-	
	800V	A	1.5	2	3	3	6	8	-	
	900V	A	1	1.5	2	2	5	6	-	
	1000V	A	1	1.5	2	2	3	4	-	
	<b>DC-PV2</b> 2 poles in series 2	500V	A	16	25	32	38	40	55	75
		600V	A	14	21	27	31	40	55	75
700V		A	13	19	22	25	35	55	65	
800V		A	12	15	17	19	33	49	52	
900V		A	8	10	12	14	25	35	38	
1000V		A	4	5	6	7	16	20	20	
1100V		A	3	4	5	-	11	15	-	
1200V		A	2	3	4	4	8	12	12	
1300V		A	1.5	2	3	-	7	10	-	
1400V		A	1	2	3	-	7	9	-	
1500V		A	1	1.5	2	2	6	8	8	
2 poles in series + 2 poles parallel 2H		500V	A	25	39	50	58	72	85	85
		600V	A	20	32	35	38	60	75	75
		700V	A	13	19	22	25	38	60	65
		800V	A	12	15	17	19	33	49	52
	900V	A	8	10	12	14	25	35	38	
	1000V	A	4	5	6	7	16	20	20	
	1100V	A	3	4	5	-	11	15	-	
	1200V	A	2	3	4	4	8	12	12	
	1300V	A	1.5	2	3	-	7	10	-	
	1400V	A	1	2	3	-	7	9	-	
	1500V	A	1	1.5	2	2	6	8	8	
	3 poles in series + 2 poles parallel 3H	500V	A	24	45	58	65	72	85	-
		600V	A	22	34	44	48	72	-	-
		700V	A	20	28	34	35	62	69	-
		800V	A	18	24	29	31	53	61	-
900V		A	16	20	24	24	55	-	-	
1000V		A	14	18	20	20	35	50	-	
1100V		A	-	-	-	-	-	-	-	
1200V		A	11	13	15	15	-	-	-	
1300V		A	-	-	-	-	-	-	-	
1400V		A	-	-	-	-	-	-	-	
1500V		A	4	6	8	8	-	-	-	
4 poles in series 4S, 4B, 4T		500V	A	16	25	32	45	48	55	75
		600V	A	16	25	32	45	48	55	75
		700V	A	16	25	32	45	48	55	75
		800V	A	16	25	32	38	40	55	75
	900V	A	16	25	32	38	40	55	65	
	1000V	A	16	25	32	38	40	55	65	
	1100V	A	15	25	32	-	-	55	-	
	1200V	A	13.5	21	27	27	40	55	55	
	1300V	A	12	19	24	-	-	50	-	
	1400V	A	10.5	16	21	-	-	45	-	
	1500V	A	9	14	18	18	30	40	40	
	4 poles in series + 2 poles parallel 4H	500V	A	29	45	58	65	72	85	-
		600V	A	29	45	58	65	72	85	-
		700V	A	25	40	53	65	72	80	-
		800V	A	21	35	45	60	67	75	-
900V		A	18	30	37	55	59	70	-	
1000V		A	16	25	32	50	52	64	-	
1100V		A	-	-	-	-	44	59	-	
1200V		A	13.5	21	27	27	40	55	-	
1300V		A	-	-	-	-	36	50	-	
1400V		A	-	-	-	-	33	45	-	
1500V		A	9	14	18	18	30	40	-	

# Technical Data continued









Data according to IEC 60947-3, VDE 0660, GB14048.3

Main Contacts		Type	SI16	SI25	SI32	SI38	SI40	SI55/SI65	
<b>DC22B</b>	1 pole 1 	500V	A	1	1.25	1.5	x	x	2.5
		600V	A	0.5	0.75	1	x	x	2
		800V	A	0.3	0.4	0.5	x	x	1.5
		1000V	A	0.15	0.2	0.25	x	x	1
		1200V	A				x	x	x
		1500V	A				x	x	x
	2 poles in series 2 	500V	A	7	8	9	x	x	x
		600V	A	5.5	6	6.5	x	x	x
		800V	A	2	2.5	3	x	x	x
		1000V	A	1	1.5	2	x	x	x
		1200V	A				x	x	x
		1500V	A				x	x	x
	4 poles in series 4S, 4B, 4T 	500V	A	16	25	32	x	x	x
		600V	A	16	25	27.5	x	x	x
		800V	A	11.5	12	12.5	x	x	x
		1000V	A	8	9	10	x	x	x
		1200V	A				x	x	x
		1500V	A				x	x	x
<b>Rated conditional short-circuit current</b>		kA <sub>eff</sub>	5	5	5	5	10	10	
Max. fuse size		gL (gG)	A	40	63	80	80	125	160
Mechanical Life		x10 <sup>3</sup>		10	10	10	10	10	10
Rated short-time withstand current (1s)	$I_{cw}$	2, 4, 6, 8	A	800	900	1000	1000	2, 4: 1200	2, 4: 1400
		2H, 3H, 4H	A	1300	1500	1700	1700	2H: 2000	2H: 2400
Short circuit making capacity	$I_{cw}$	2, 4, 6, 8	A	800	900	1000	1000	2, 4: 1200	2, 4: 1400
		2H, 3H, 4H	A	1300	1500	1700	1700	2H: 2000	2H: 2400
<b>Maximum cable cross sections</b> (including jumper)			SIV-B1-1				SIV-B2-1		
solid or stranded	mm <sup>2</sup>	4 - 16	4 - 16	4 - 16	4 - 16	4 - 16	2.5 - 25	2.5 - 25	
flexible	mm <sup>2</sup>	4 - 10	4 - 10	4 - 10	4 - 10	4 - 10	4 - 16	4 - 16	
flexible (+ multicore cable end)	mm <sup>2</sup>	4 - 10	4 - 10	4 - 10	4 - 10	4 - 10	2.5 - 16	2.5 - 16	
Size of terminal screw		M4 Pz2	M4 Pz2	M4 Pz2	M4 Pz2	M4 Pz2	M5 Pz2	M5 Pz2	
Tightening torque	Nm	1.7 - 1.8	1.7 - 1.8	1.7 - 1.8	1.7 - 1.8	1.7 - 1.8	2.5 - 2.8	2.5 - 2.8	
2 cables per clamp without jumper									
solid or stranded	mm <sup>2</sup>	16+(1.5-2.5)/10+(1.5-6)/6+(1.5-10)/4+(1.5-10)				16+(1.5-2.5)/10+(1.5-10)/6+(1.5-10)/4+(1.5-10)			
flexible & flexible + multicore cable end	mm <sup>2</sup>	16+(1.5-2.5)/10+(1.5-4)/6+(1.5-6)				16+(1.5-6)/10+(1.5-10)/6+(1.5-16)/4+(1.5-16)			
stranded	AWG	8+(16-12)/10+(16-10)/12+(16-8)/14+(16-8)				3+(18-10)/4+(18-10)/6+(18-8)/8+(18-8)			
solid	AWG	10+(16-12)/12+(16-10)/14+(16-10)				10+(16-10)/12+(16-10)/14+(16-10)			
<b>Maximum ambient temperature</b>									
Operation	All types except PEL64R	°C	-40 to +65						
	PEL64R type	°C	-40 to +45						
Storage		°C	-50 to +90						
<b>Power loss per switch at <math>I_{e max}</math></b>			A	A	A		A	A	
2	(A) / W	(16) / 1	(25) / 2.3	(32) / 3.7		(40) / 4	(55) / 7.5		
4	(A) / W	(16) / 2	(25) / 4.6	(32) / 7.4		(40) / 8	(55) / 15		
6	(A) / W	(16) / 3	(25) / 6.9	(32) / 11.1		(40) / 12	(55) / 22.5		
8	(A) / W	(16) / 4	(25) / 9.2	(32) / 14.8		(40) / 16	(55) / 30		
2H	(A) / W	(29) / 1.5	(45) / 3.7	(58) / 6		(72) / 6.5	(85) / 9		
3H	(A) / W	(29) / 2.3	(45) / 5.6	(58) / 9		(72) / 9.8	(85) / 14		
4H	(A) / W	(29) / 3	(45) / 7.4	(58) / 12		(72) / 13	(85) / 18		
Contact Resistance per pole		mΩ	1.75	1.75	1.75	1.75	1.25	1.25	

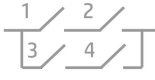
x - In Test

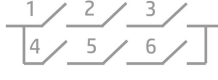
# Technical Data continued

Data according to UL508i  File E362605, CCN: NMSJ and UL60947-1 & UL60947-4-1  File E146487, CCN: NRNT, NRNT7

Main Contacts		Type	SI16	SI25	SI32	SI38	SI40	SI55	SI65
Ampere-Rating "General Use"		DC							
1 pole 1 	350V	A	4	5	6	6	7.1	10	10
	500V	A	4	5	6	6	5.7	7	7
	600V	A	4	5	6	6	5	5.8	5.8
	700V	A					3.9	5	5
	800V	A					3.2	4.4	4.4
	900V	A					2.5	3.5	3.5
	1000V	A					1.5	2	2
2 poles in series 2 	350V	A	16	25	32	45	48	55	65
	500V	A	16	25	32	45	48	55	65
	600V	A	16	25	32	36	40	55	65
	700V	A					32	46	50
	800V	A					26	37	40
	900V	A					20	28	32
	1000V	A					16	20	25
2 poles in series + 2 poles parallel 2H 	350V	A	29	45	58	58	72	85	85
	500V	A	29	41	43	45	53	66	73
	600V	A	21	30	33	36	42	55	65
	700V	A					35	47	50
	800V	A					30	40	40
	900V	A					26	32	32
	1000V	A					22	25	25
4 poles in series 4S, 4B, 4T 	350V	A	16	25	32	45	48	55	65
	500V	A	16	25	32	45	48	55	65
	600V	A	16	25	32	36	40	55	65
	700V	A					40	55	65
	800V	A					40	55	65
	900V	A					40	55	65
	1000V	A					40	55	65
3 poles in series + 2 poles parallel 3H 	350V	A	29	45	58	58	72	85	85
	500V	A	29	41	50	50	56	80	85
	600V	A	21	38	45	45	52	65	72
	700V	A					46	58	66
	800V	A					40	51	60
	900V	A					36	45	54
	1000V	A					33	42	48
4 poles in series + 2 poles parallel 4H 	350V	A	29	45	58	58	80	85	85
	500V	A	29	45	58	58	71	85	85
	600V	A	29	45	50	50	65	85	85
	700V	A					58	76	85
	800V	A					51	71	76
	900V	A					45	67	73
	1000V	A					42	64	70
AC Rating "General Use"		600V	A	16	25	32	40	55	-
2 poles in series + 2 poles parallel		277V	A			50	72	85	-
3 poles parallel		3x480V	A			32	40	55	-
Fuse size (RK5) Industrial Control Switch									
5kA / 600V		A	40	60	80	80	-	-	-
5kA / 1000V		A					160	160	160
<b>Maximum cable cross sections</b>	(including jumper SIV-B1-1/B2-1)								
solid or stranded	AWG		12 - 10	12 - 10	12 - 10	12 - 10	16 - 10	16 - 10	16 - 10
flexible	AWG		12 - 6	12 - 6	12 - 6	12 - 6	14 - 4	14 - 4	14 - 4
flexible (+ multicore cable end)	AWG		12 - 6	12 - 6	12 - 6	12 - 6			
Size of terminal screw			M4 Pz2	M4 Pz2	M4 Pz2	M4 Pz2	M5 Pz2	M5 Pz2	M5 Pz2
Tightening torque	lb.inch		9 - 16	9 - 16	9 - 16	9 - 16	22 - 25	22 - 25	22 - 25

x - In Test

# Technical Data continued

Switch SI16 2 poles DC-PV1 Open Type

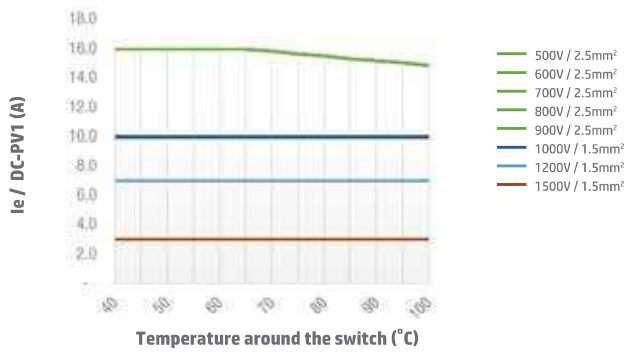

Switch SI16 2 poles DC-PV1 Enclosed Type

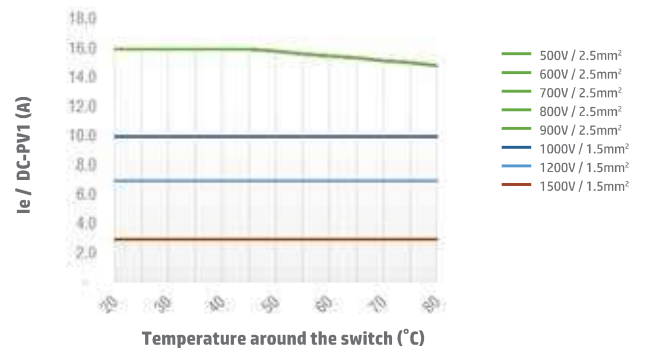

Switch SI16 2H DC-PV1 Open Type

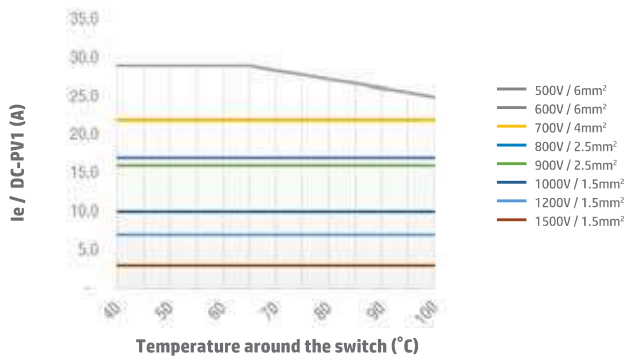

Switch SI16 2H DC-PV1 Enclosed Type

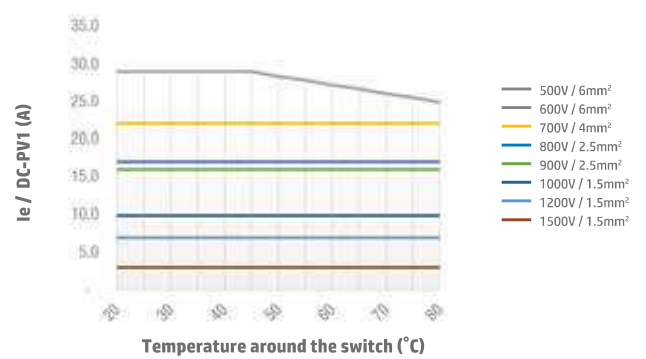

Switch SI16 4B/4S/4T DC-PV1 Open Type

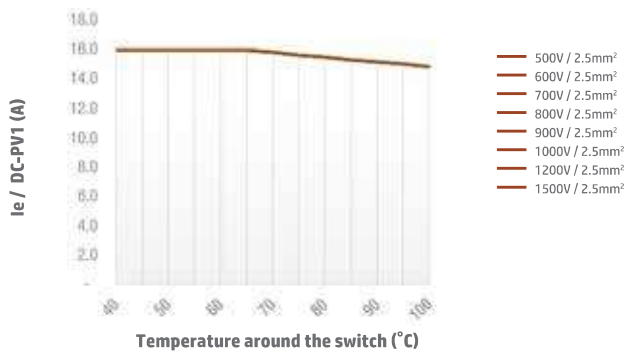

Switch SI16 4B/4S/4T DC-PV1 Enclosed Type

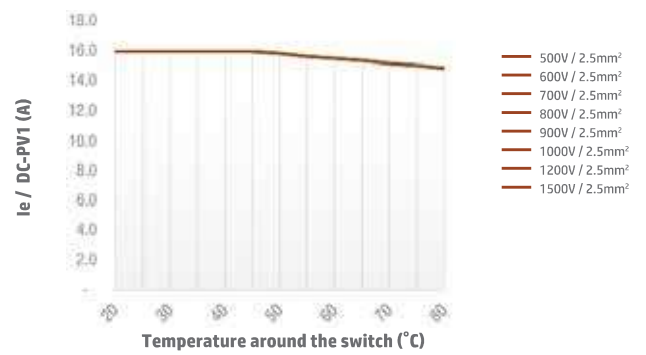

Switch SI16 4H DC-PV1 Open Type

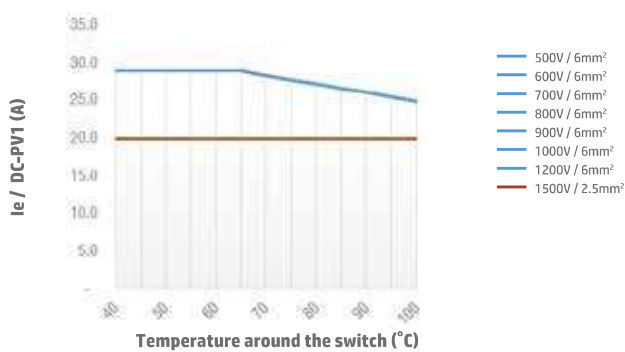

Switch SI16 4H DC-PV1 Enclosed Type

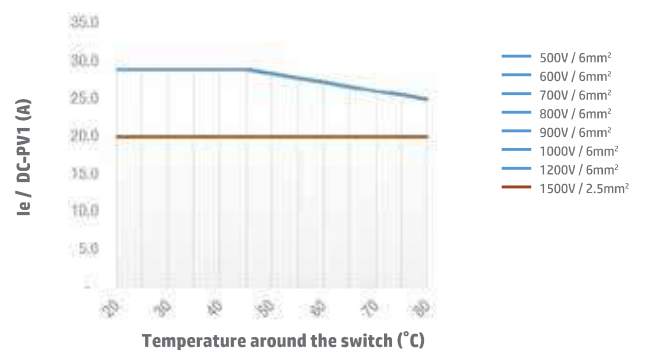

# Technical Data continued

Switch SI25 2 poles DC-PV1 Open Type

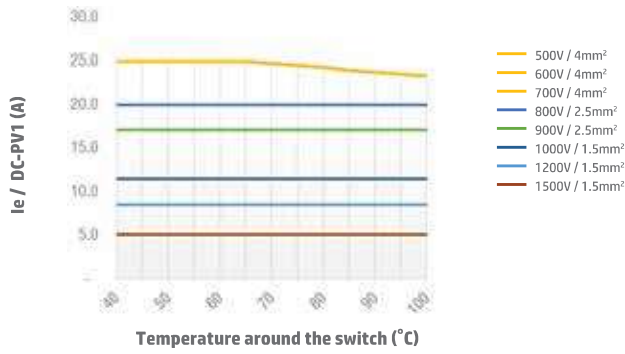

Switch SI25 2 poles DC-PV1 Enclosed Type

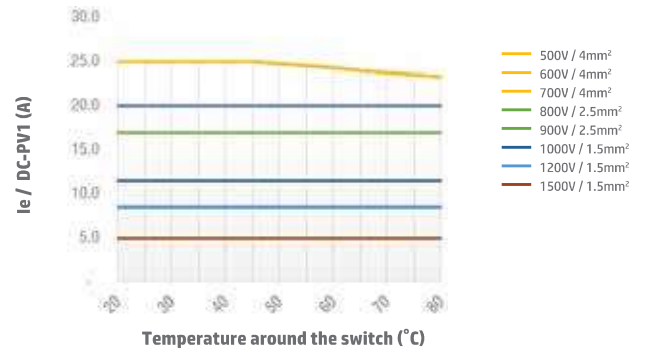

Switch SI25 2H DC-PV1 Open Type

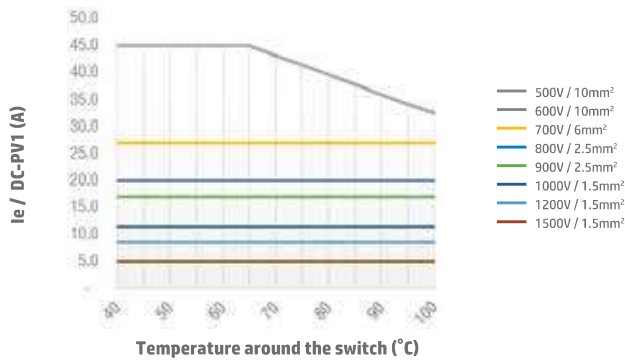

Switch SI25 2H DC-PV1 Enclosed Type

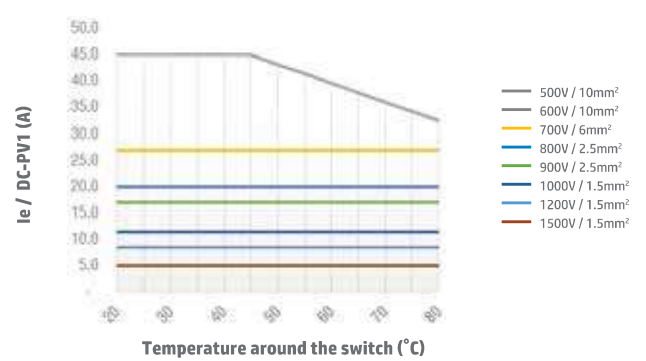

Switch SI25 4B/4S/4T DC-PV1 Open Type

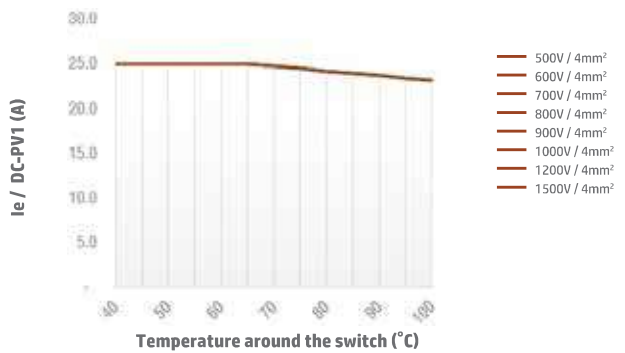

Switch SI25 4B/4S/4T DC-PV1 Enclosed Type

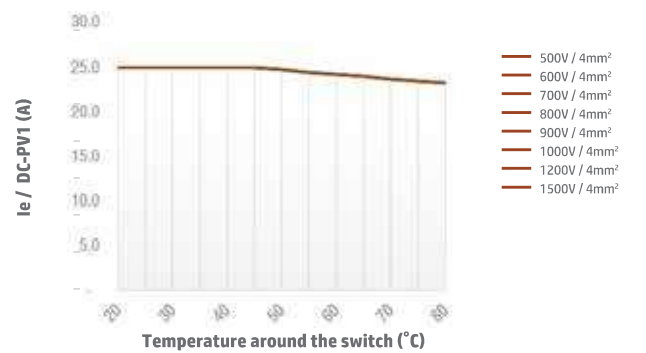

Switch SI25 4H DC-PV1 Open Type

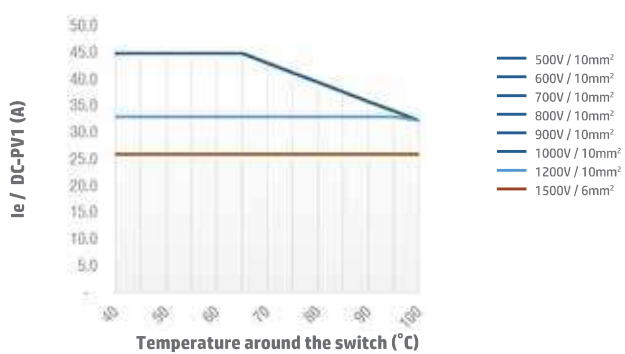

Switch SI25 4H DC-PV1 Enclosed Type

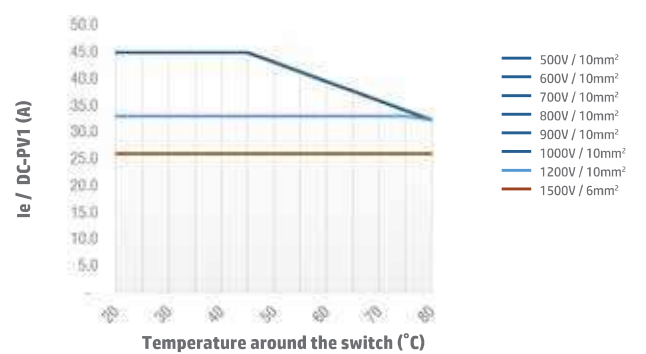

# Technical Data continued

Switch SI32 2 poles DC-PV1 Open Type

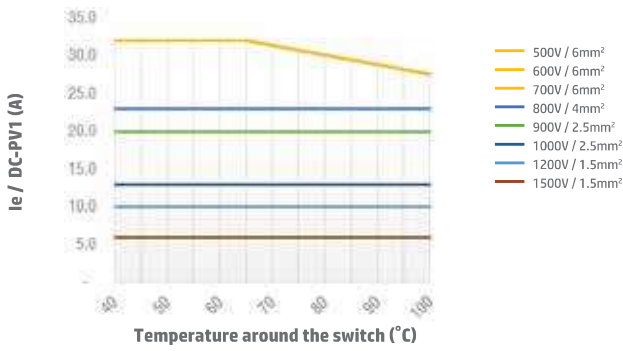

Switch SI32 2 poles DC-PV1 Enclosed Type

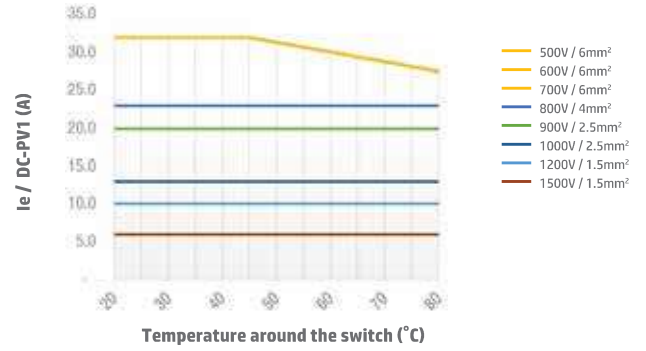

Switch SI32 2H DC-PV1 Open Type

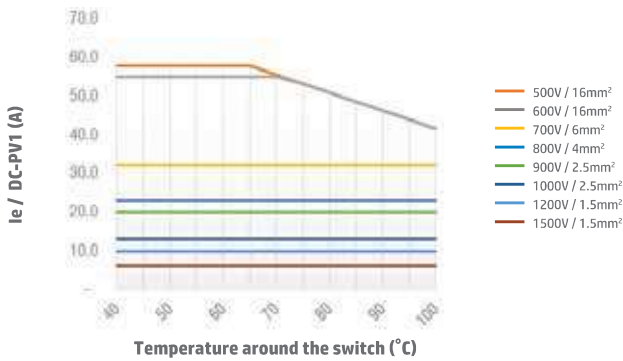

Switch SI32 2H DC-PV1 Enclosed Type

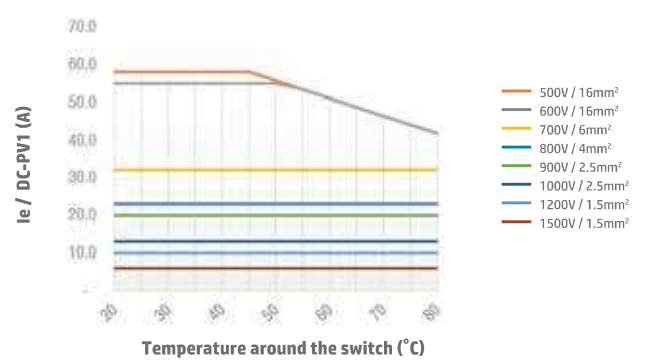

Switch SI32 4B/4S/4T DC-PV1 Open Type

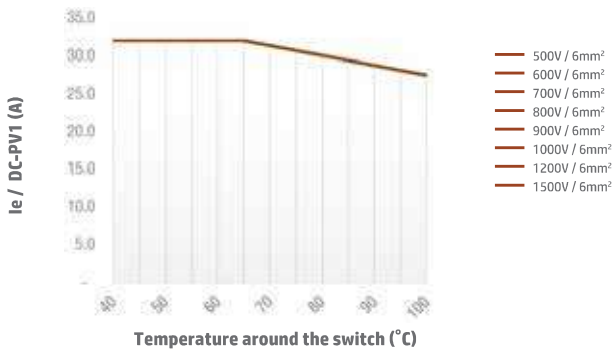

Switch SI32 4B/4S/4T DC-PV1 Enclosed Type

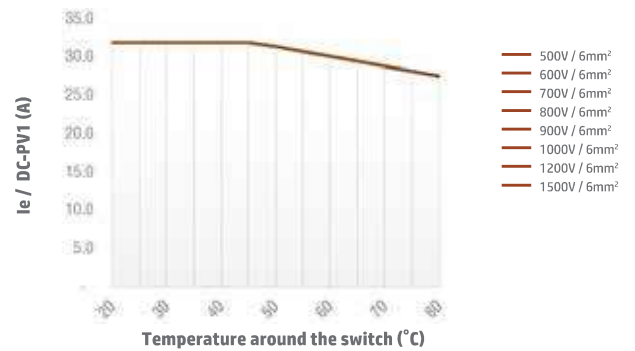

Switch SI32 4H DC-PV1 Open Type

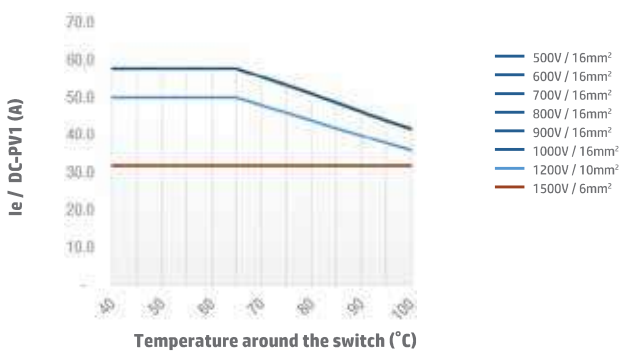

Switch SI32 4H DC-PV1 Enclosed Type

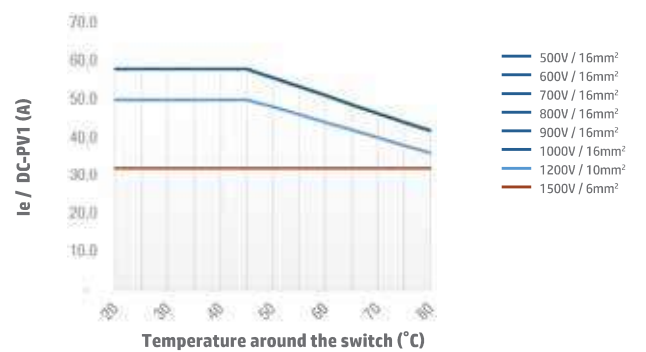

# Technical Data continued

Switch SI38 2 poles DC-PV1 Open Type

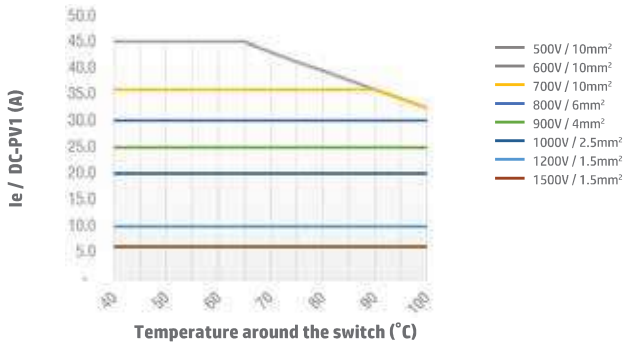

Switch SI38 2 poles DC-PV1 Enclosed Type

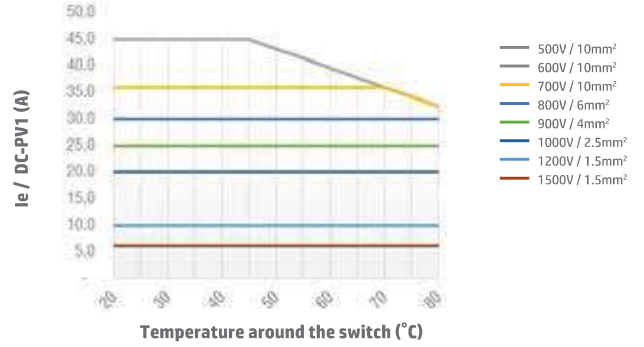

Switch SI38 2H DC-PV1 Open Type

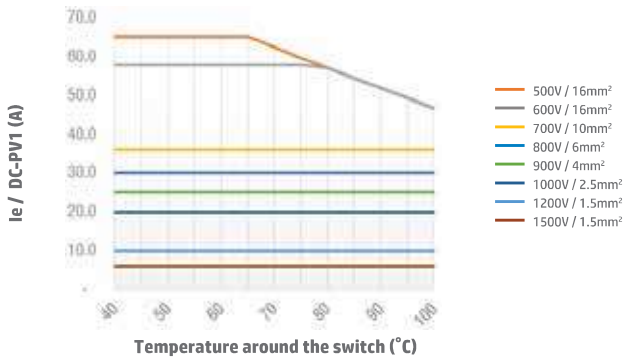

Switch SI38 2H DC-PV1 Enclosed Type

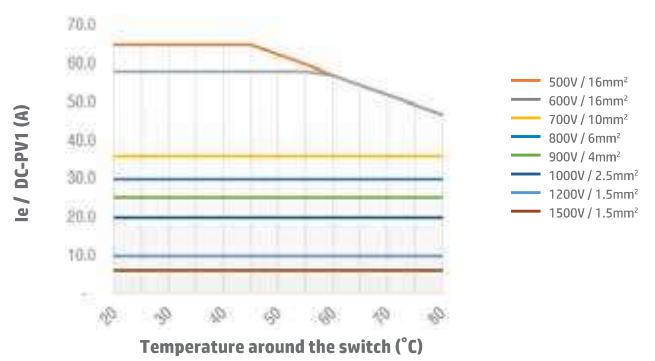

Switch SI38 4B/4S/4T DC-PV1 Open Type

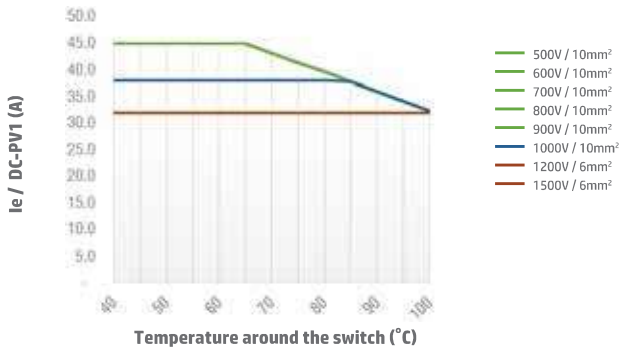

Switch SI38 4B/4S/4T DC-PV1 Enclosed Type

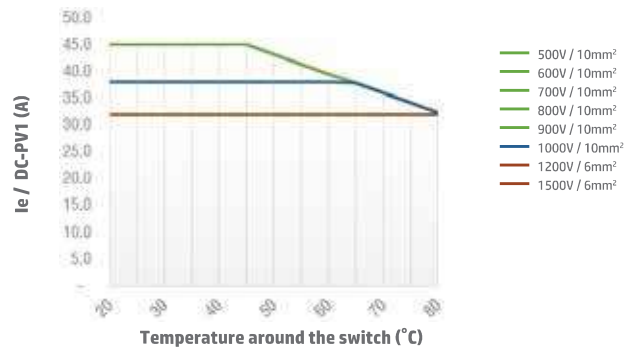

Switch SI38 4H DC-PV1 Open Type

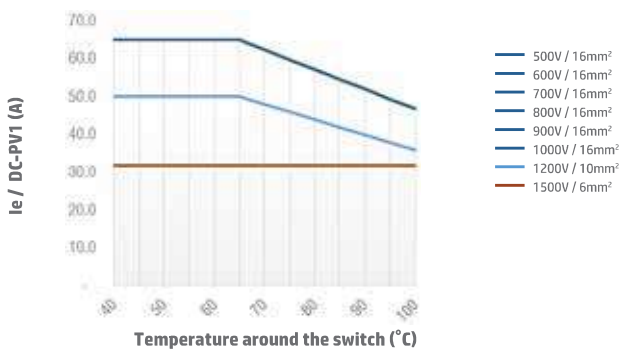

Switch SI38 4H DC-PV1 Enclosed Type

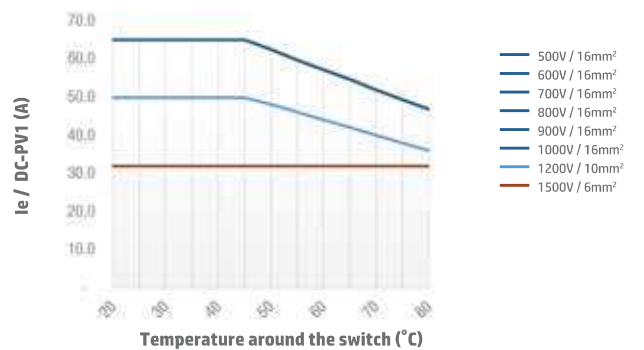

# Technical Data continued

Switch SI40 2 poles DC-PV1 Open Type

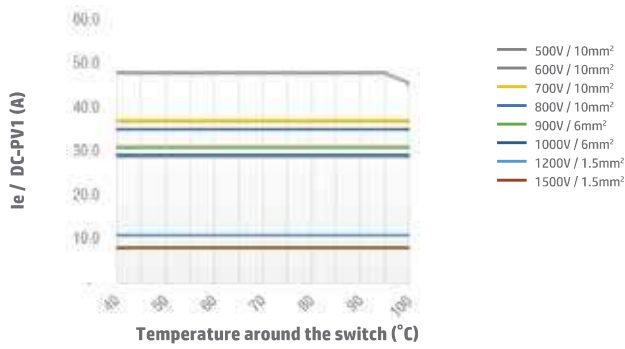

Switch SI40 2 poles DC-PV1 Enclosed Type

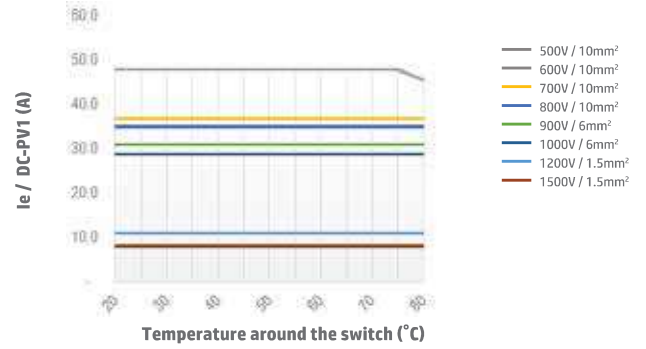

Switch SI40 2H DC-PV1 Open Type

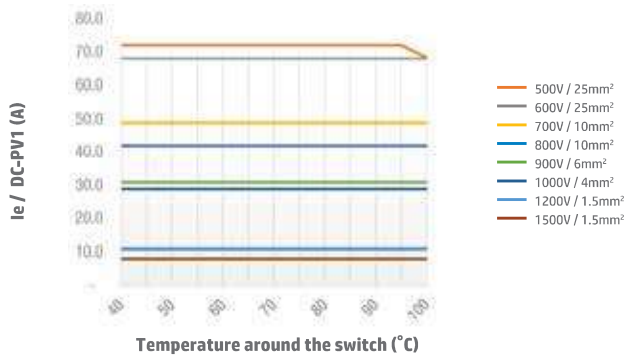

Switch SI40 2H DC-PV1 Enclosed Type

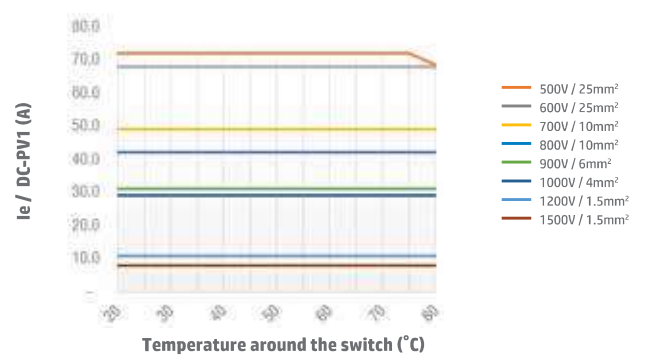

Switch SI40 4B/4S/4T DC-PV1 Open Type

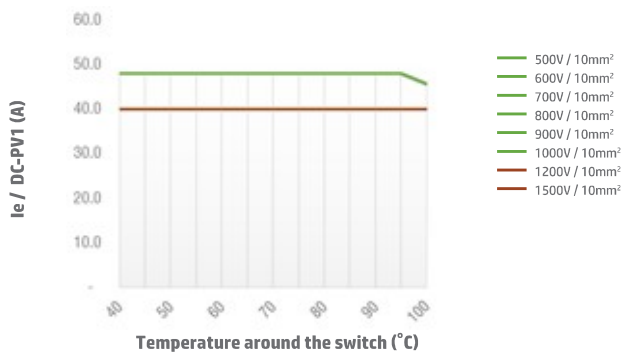

Switch SI40 4B/4S/4T DC-PV1 Enclosed Type

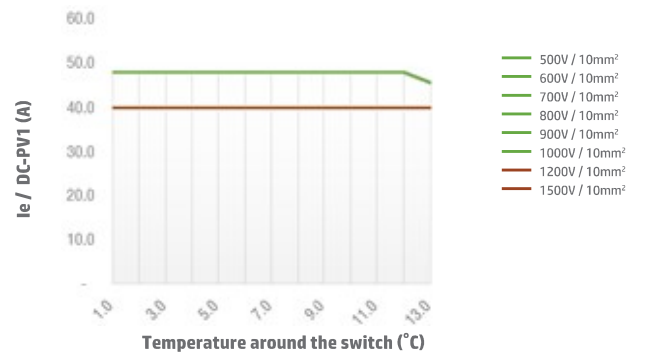

Switch SI40 4H DC-PV1 Open Type

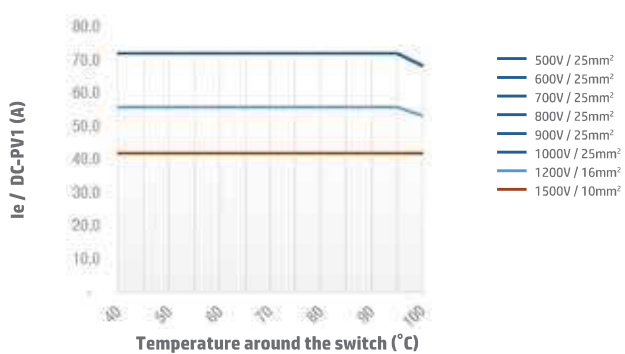

Switch SI40 4H DC-PV1 Enclosed Type

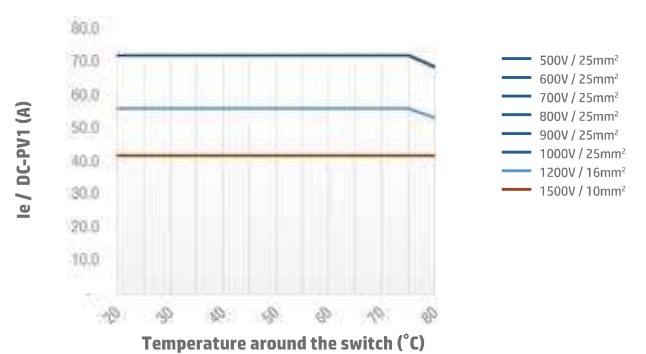

**Note:** For SI40 3H pole configuration, DC-PV1 derating graphs can be supplied upon request. Please contact IMO for more information.

# Technical Data continued

Switch SI55 2 poles DC-PV1 Open Type

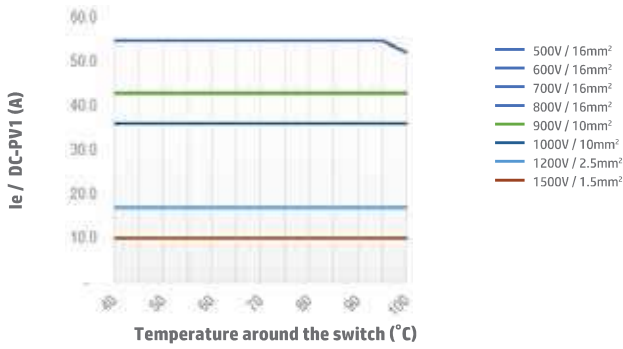

Switch SI55 2 poles DC-PV1 Enclosed Type

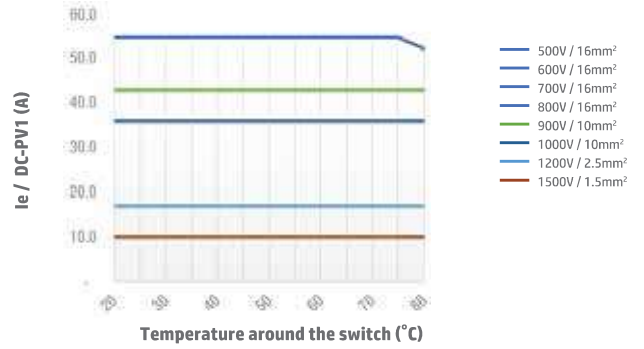

Switch SI55 2H DC-PV1 Open Type

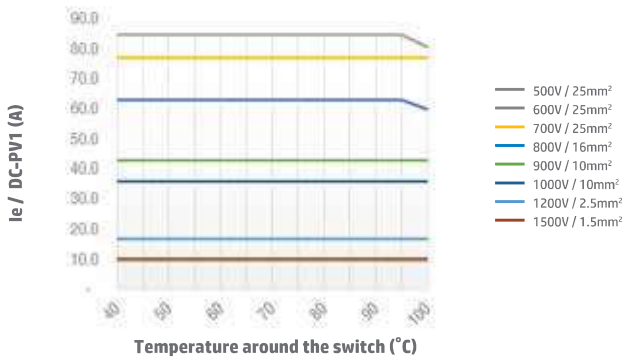

Switch SI55 2H DC-PV1 Enclosed Type

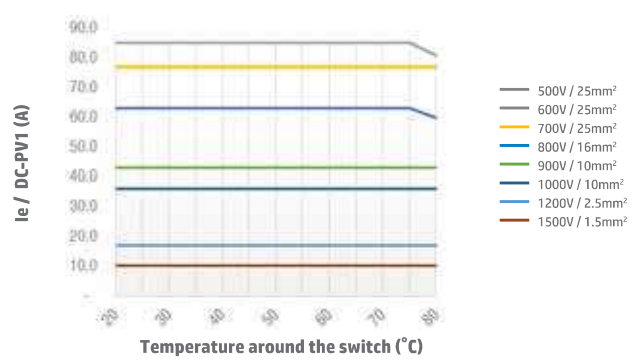

Switch SI55 4B/4S/4T DC-PV1 Open Type

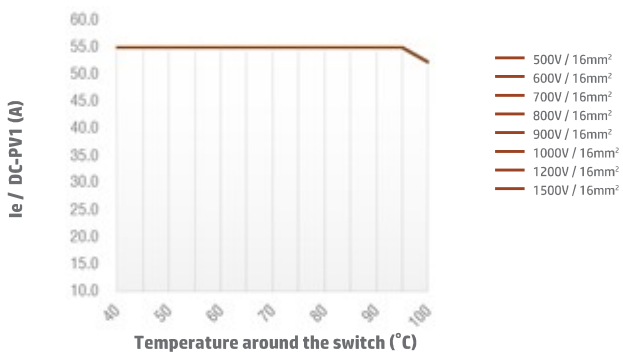

Switch SI55 4B/4S/4T DC-PV1 Enclosed Type

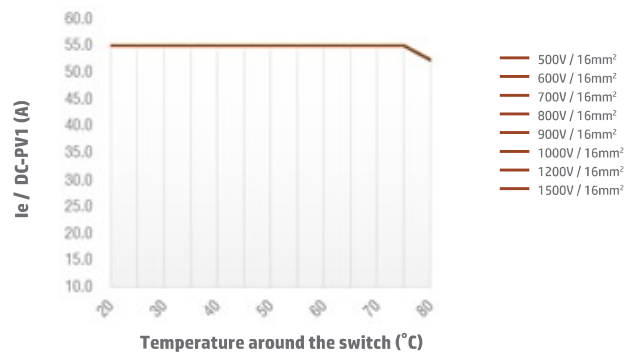

Switch SI55 4H DC-PV1 Open Type

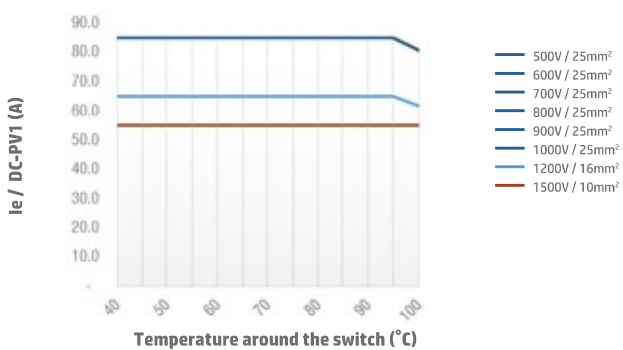

Switch SI55 4H DC-PV1 Enclosed Type

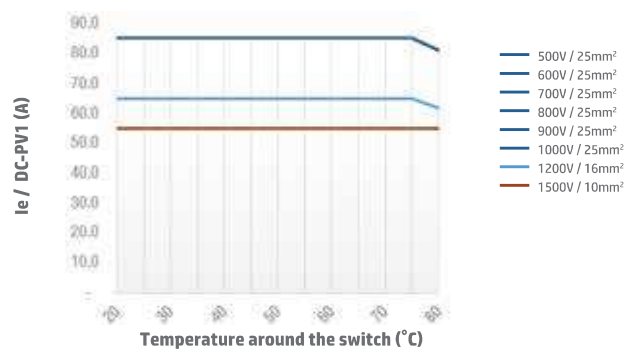

Note: SI55 3H pole configuration and SI65, DC-PV1 derating graphs can be supplied upon request. Please contact IMO for more information.

# Technical Data continued

Switch SI16 2 poles DC-PV2 Open Type

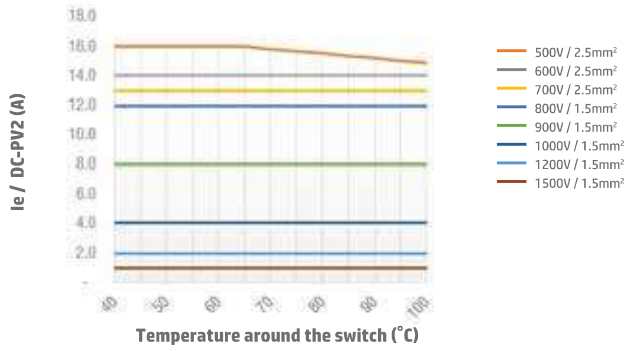

Switch SI16 2 poles DC-PV2 Enclosed Type

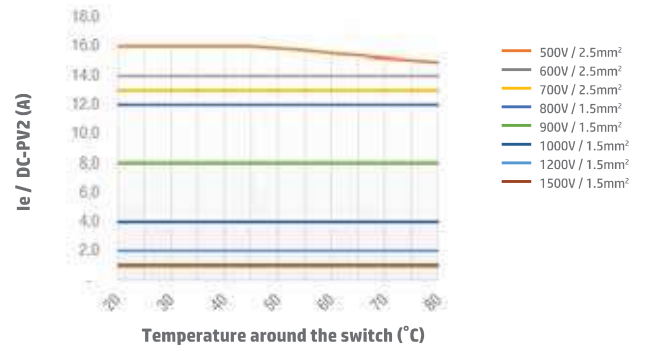

Switch SI16 2H DC-PV2 Open Type

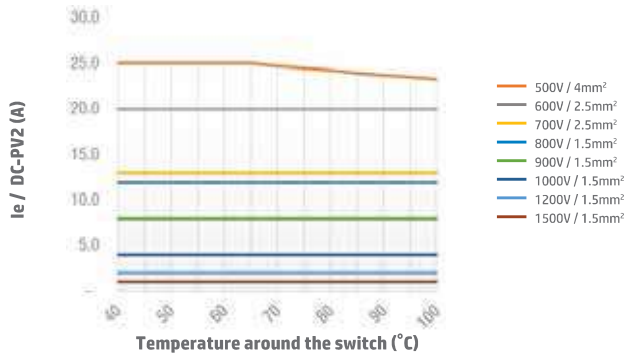

Switch SI16 2H DC-PV2 Enclosed Type

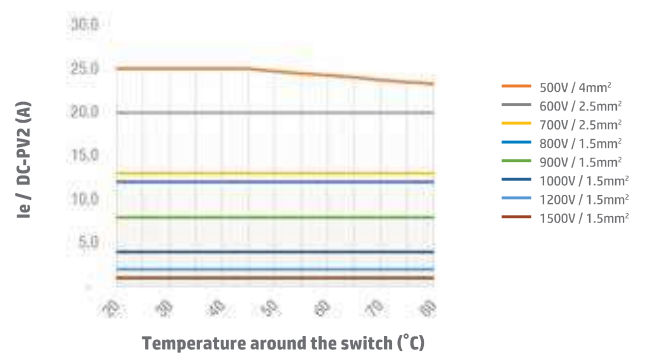

Switch SI16 4B/4S/4T DC-PV2 Open Type

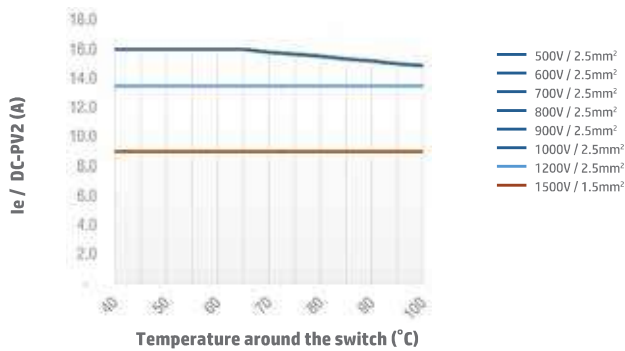

Switch SI16 4B/4S/4T DC-PV2 Enclosed Type

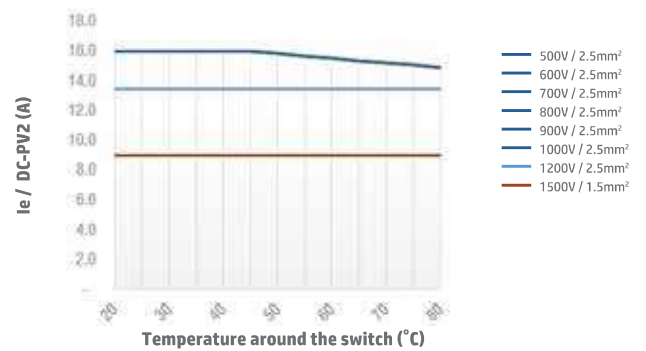

Switch SI16 4H DC-PV2 Open Type

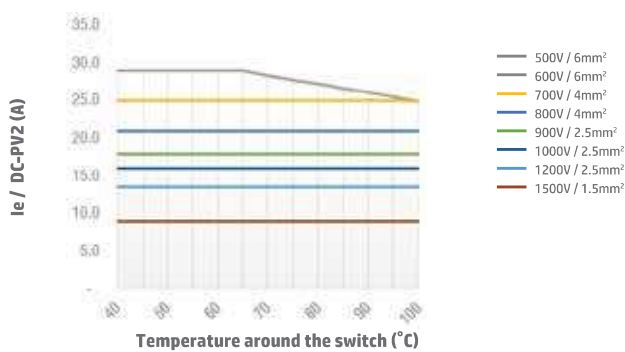

Switch SI16 4H DC-PV2 Enclosed Type

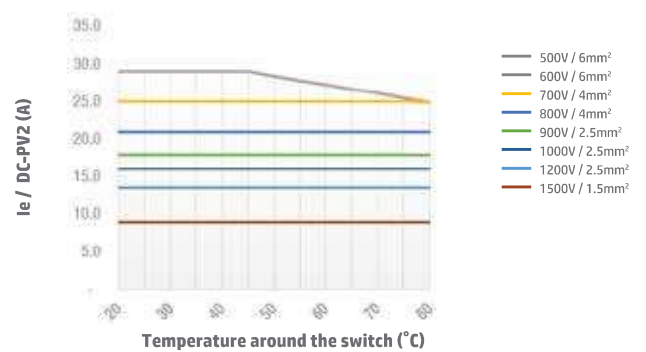

Note: For SI16 3H pole configuration, DC-PV2 derating graphs can be supplied upon request. Please contact IMO for more information.

# Technical Data continued

Switch SI25 2 poles DC-PV2 Open Type

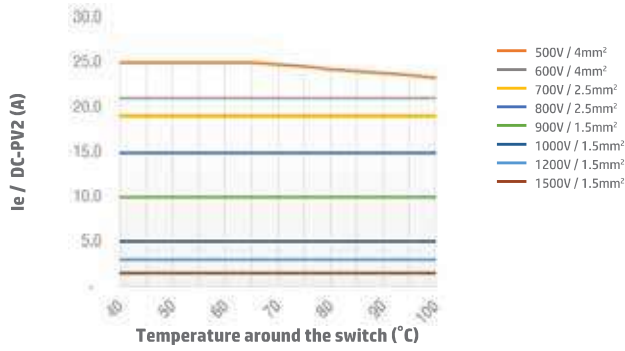

Switch SI25 2 poles DC-PV2 Enclosed Type

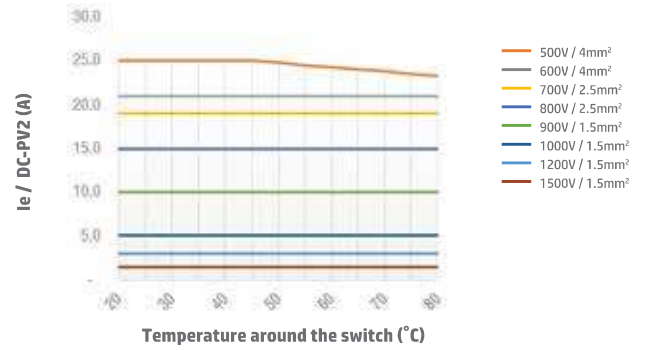

Switch SI25 2H DC-PV2 Open Type

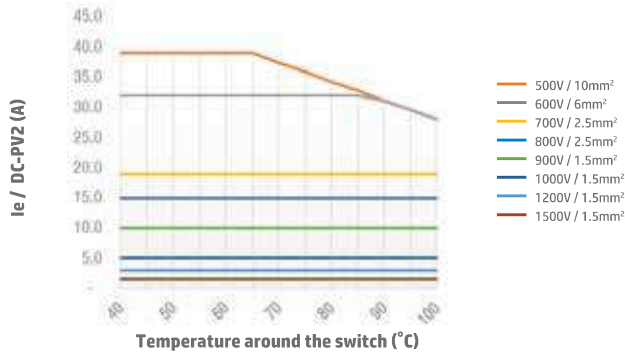

Switch SI25 2H DC-PV2 Enclosed Type

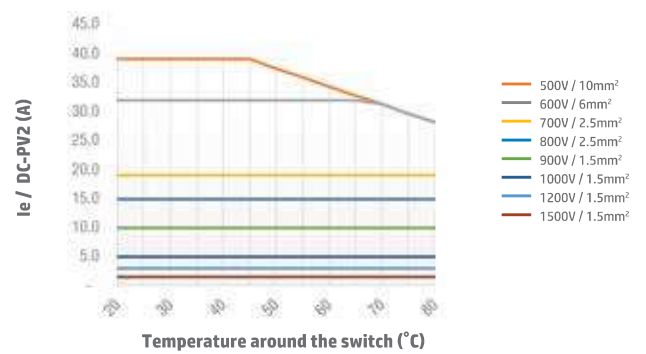

Switch SI25 4B/4S/4T DC-PV2 Open Type

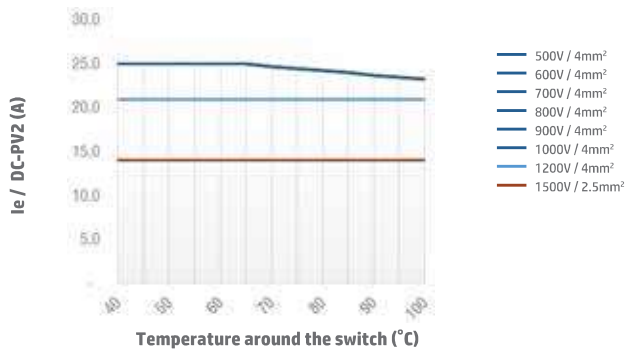

Switch SI25 4B/4S/4T DC-PV2 Enclosed Type

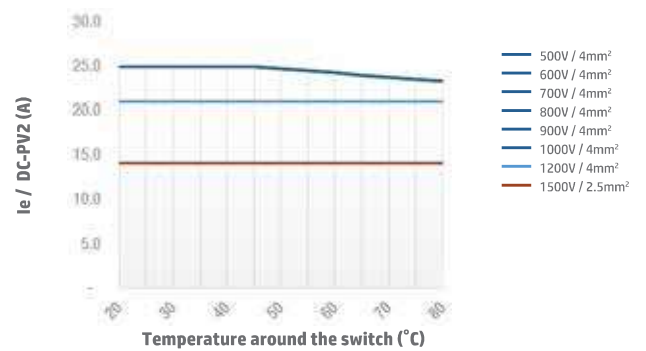

Switch SI25 4H DC-PV2 Open Type

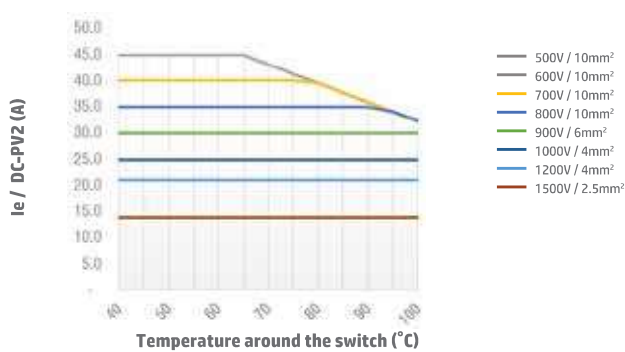

Switch SI25 4H DC-PV2 Enclosed Type

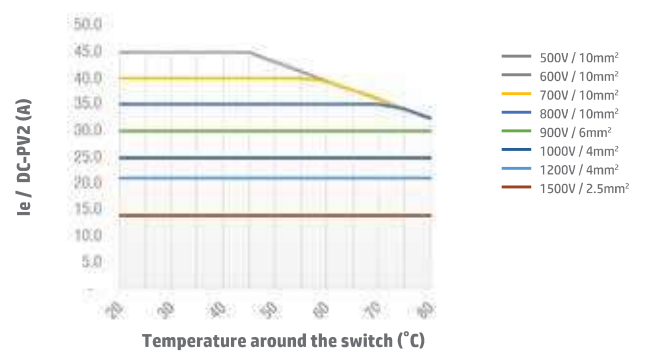

Note: For SI25 3H pole configuration, DC-PV2 derating graphs can be supplied upon request. Please contact IMO for more information.

# Technical Data continued

Switch SI32 2 poles DC-PV2 Open Type

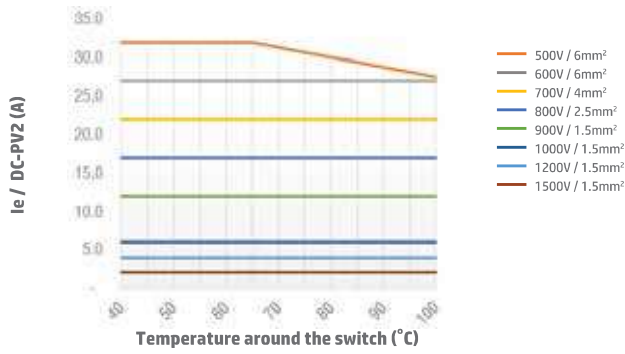

Switch SI32 2 poles DC-PV2 Enclosed Type

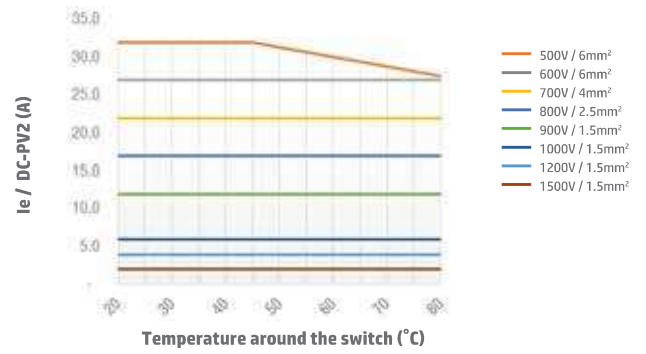

Switch SI32 2H DC-PV2 Open Type

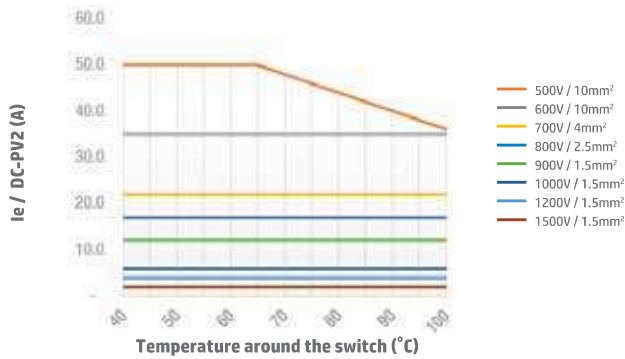

Switch SI32 2H DC-PV2 Enclosed Type

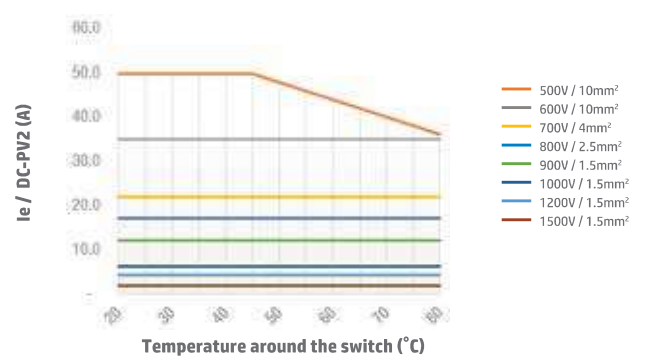

Switch SI32 4B/4S/4T DC-PV2 Open Type

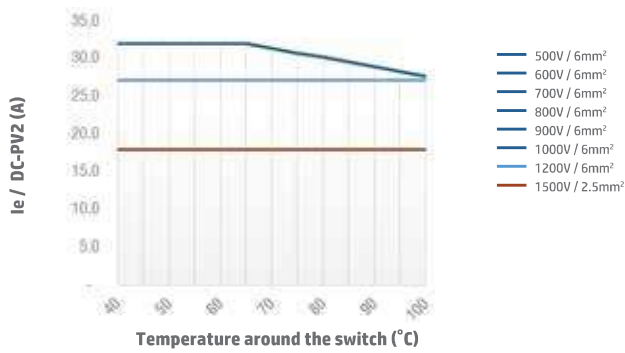

Switch SI32 4B/4S/4T DC-PV2 Enclosed Type

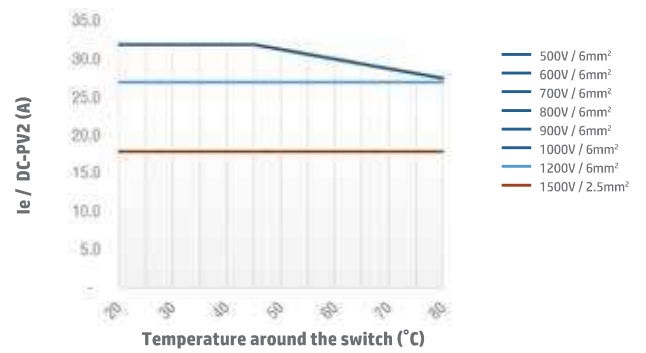

Switch SI32 4H DC-PV2 Open Type

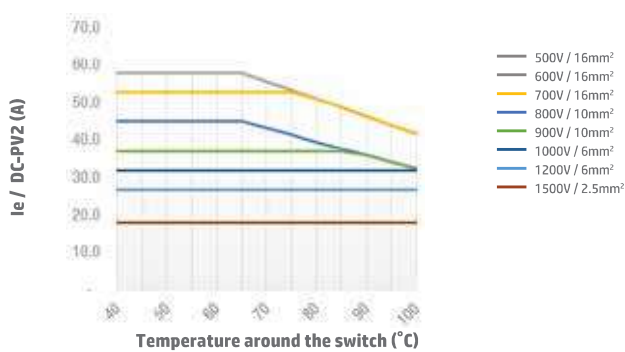

Switch SI32 4H DC-PV2 Enclosed Type

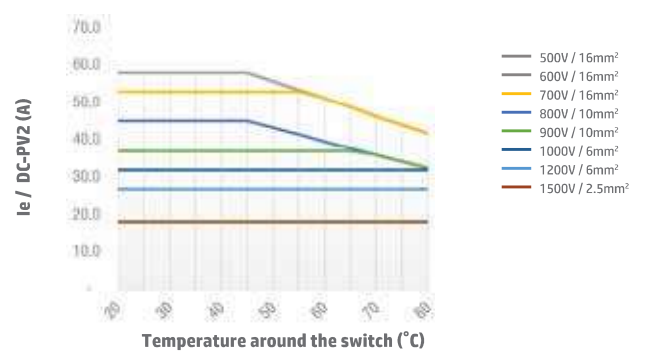

Note: For SI32 3H pole configuration, DC-PV2 derating graphs can be supplied upon request. Please contact IMO for more information.

# Technical Data continued

Switch SI38 2 poles DC-PV2 Open Type

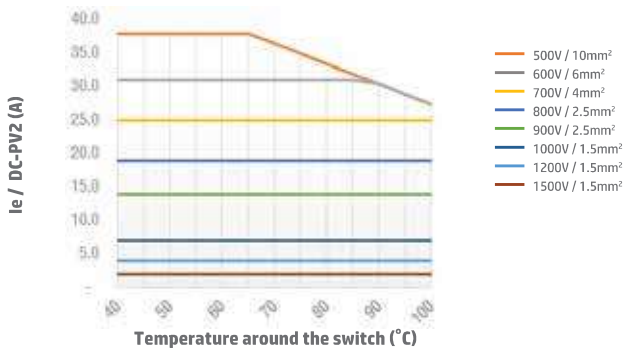

Switch SI38 2 poles DC-PV2 Enclosed Type

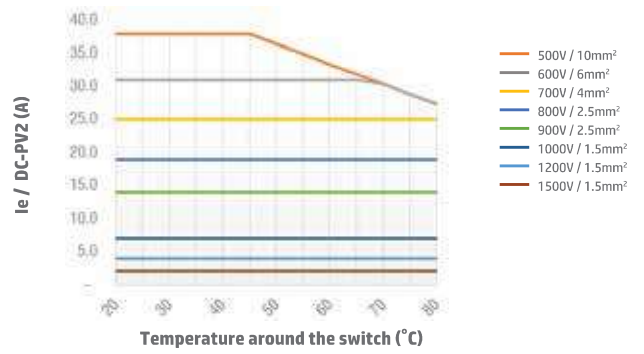

Switch SI38 2H DC-PV2 Open Type

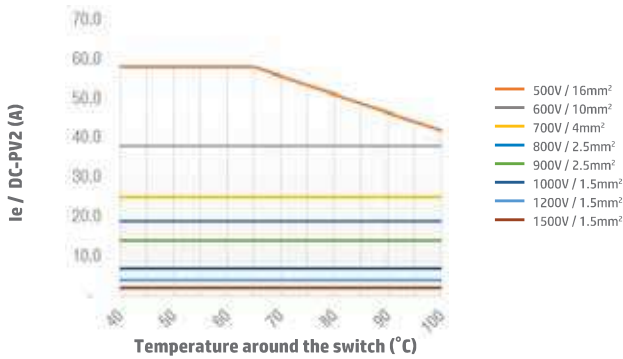

Switch SI38 2H DC-PV2 Enclosed Type

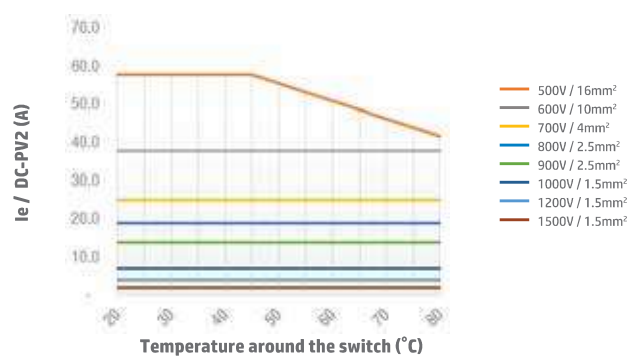

Switch SI38 4B/4S/4T DC-PV2 Open Type

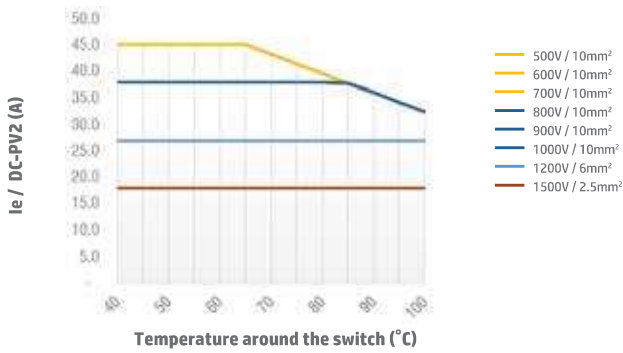

Switch SI38 4B/4S/4T DC-PV2 Enclosed Type

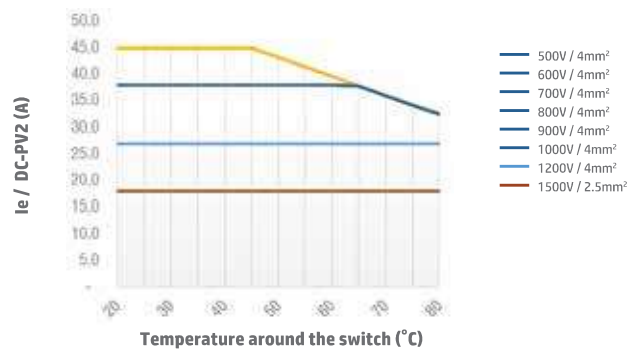

Switch SI38 4H DC-PV2 Open Type

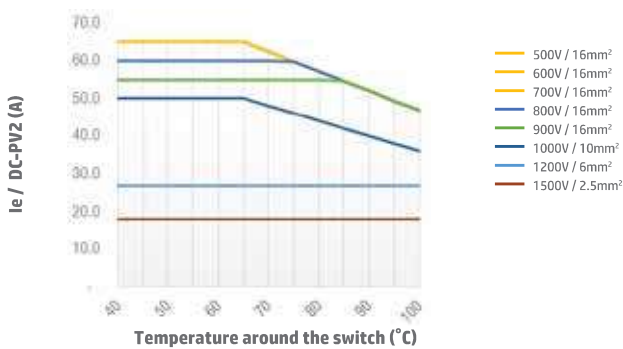

Switch SI38 4H DC-PV2 Enclosed Type

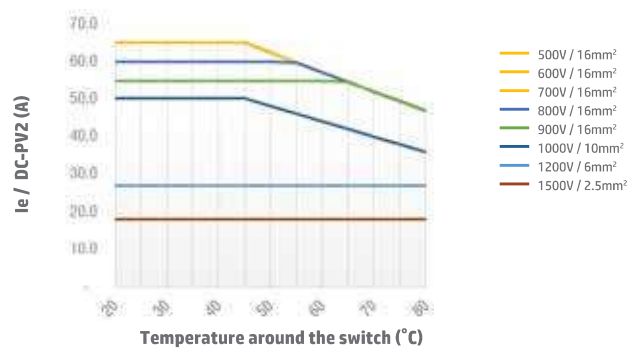

Note: For SI38 3H pole configuration, DC-PV2 derating graphs can be supplied upon request. Please contact IMO for more information.

# Technical Data continued

Switch SI40 2 poles DC-PV2 Open Type

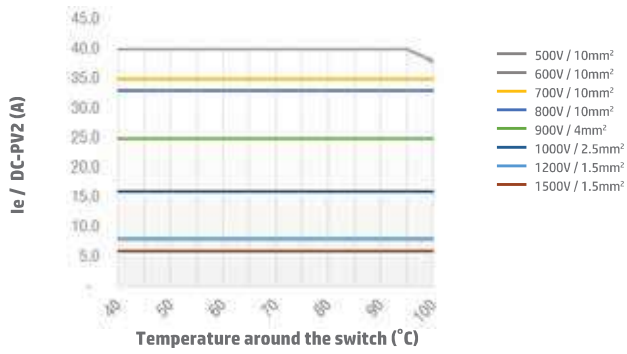

Switch SI40 2 poles DC-PV2 Enclosed Type

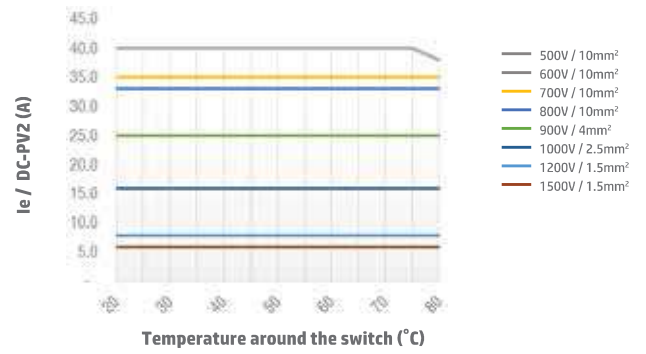

Switch SI40 2H DC-PV2 Open Type

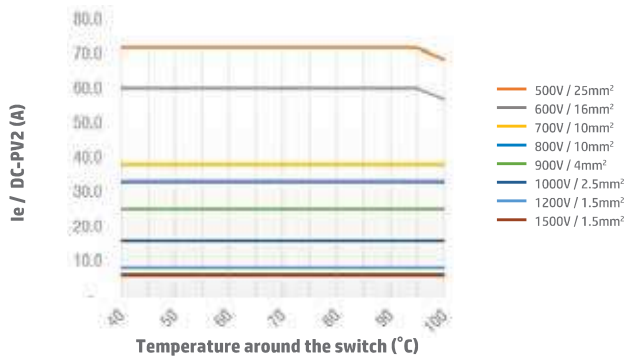

Switch SI40 2H DC-PV2 Enclosed Type

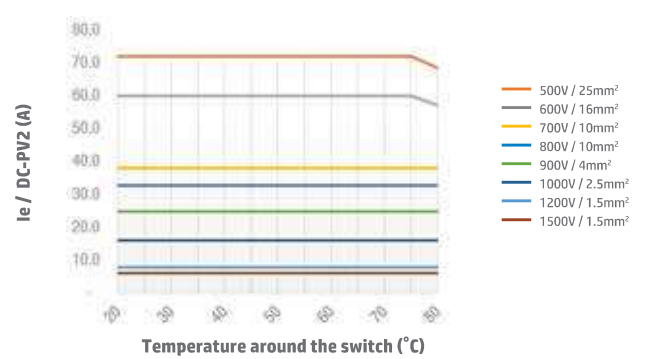

Switch SI40 4B/4S/4T DC-PV2 Open Type

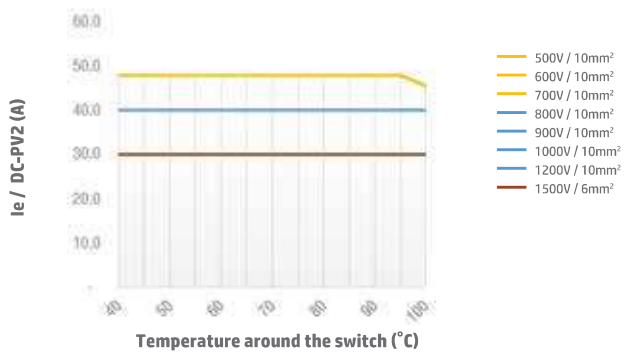

Switch SI40 4B/4S/4T DC-PV2 Enclosed Type

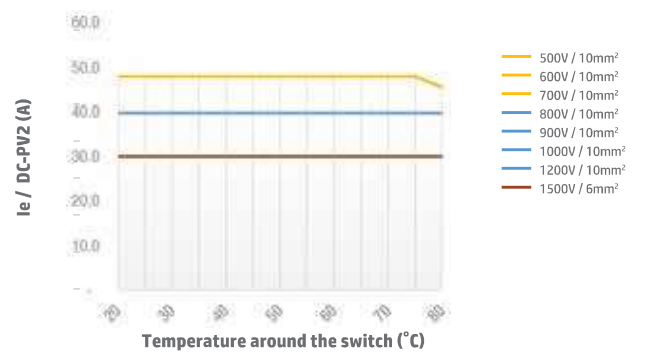

Switch SI40 4H DC-PV2 Open Type

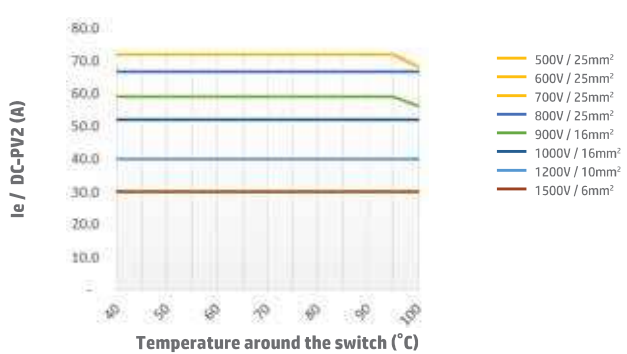

Switch SI40 4H DC-PV2 Enclosed Type

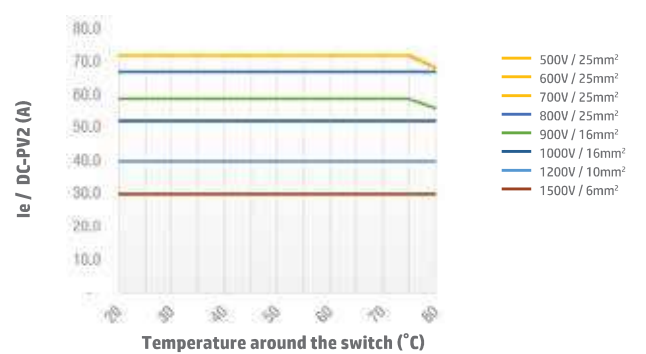

**Note:** For SI40 3H pole configuration, DC-PV2 derating graphs can be supplied upon request. Please contact IMO for more information.

# Technical Data continued

Switch SI55 2 poles DC-PV2 Open Type

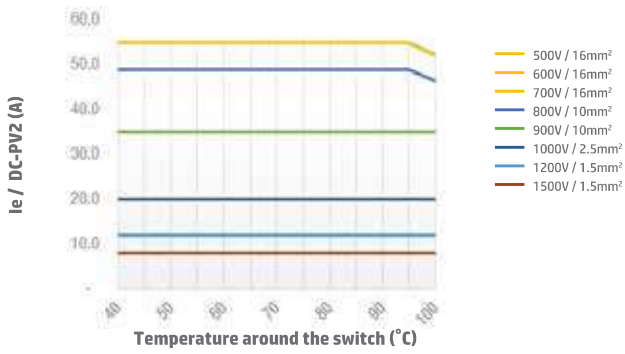

Switch SI55 2 poles DC-PV2 Enclosed Type

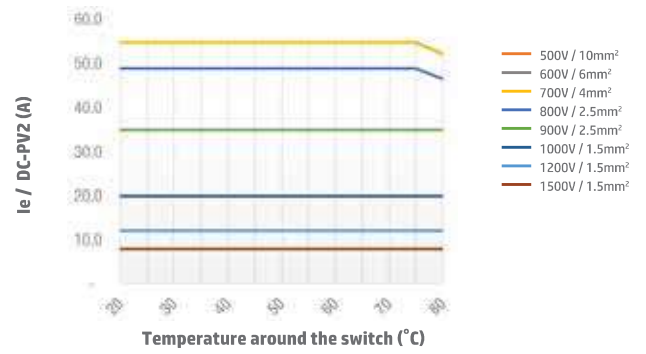

Switch SI55 2H DC-PV2 Open Type

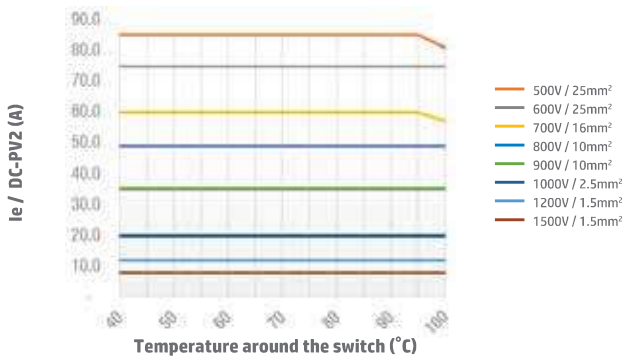

Switch SI55 2H DC-PV2 Enclosed Type

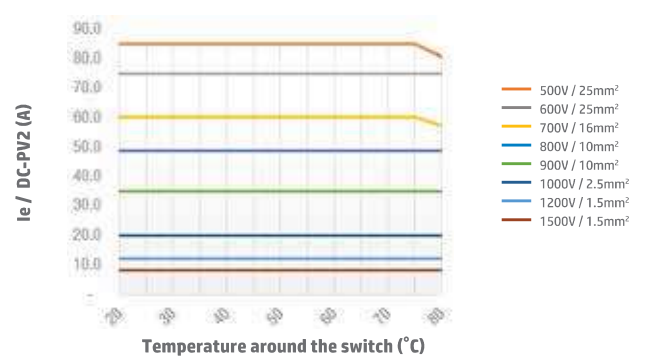

Switch SI55 4B/4S/4T DC-PV2 Open Type

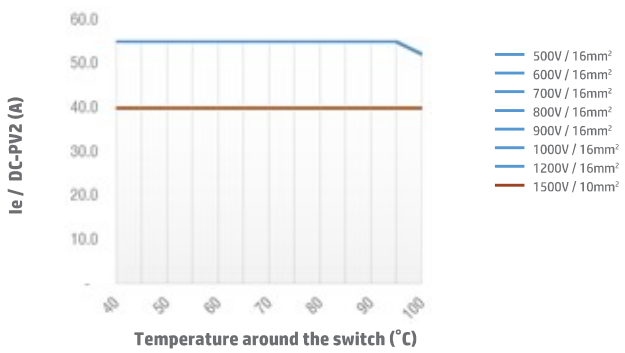

Switch SI55 4B/4S/4T DC-PV2 Enclosed Type

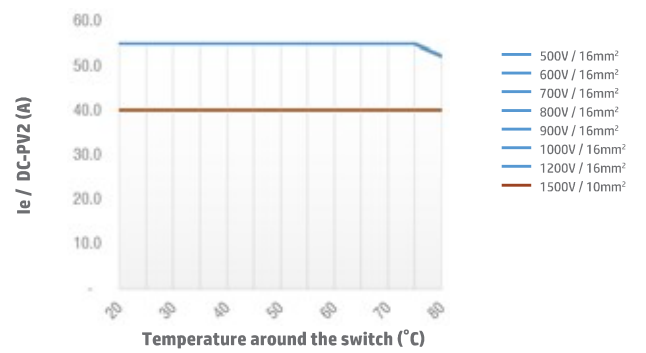

Switch SI55 4H DC-PV2 Open Type

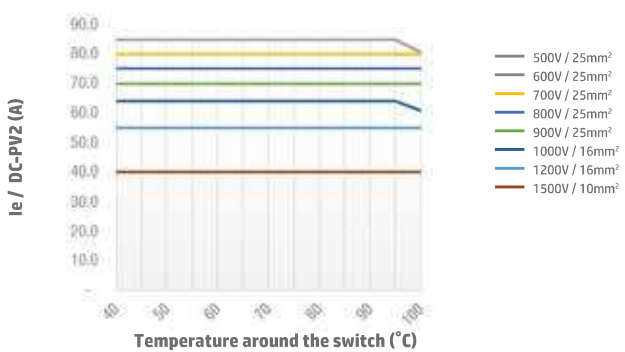

Switch SI55 4H DC-PV2 Enclosed Type

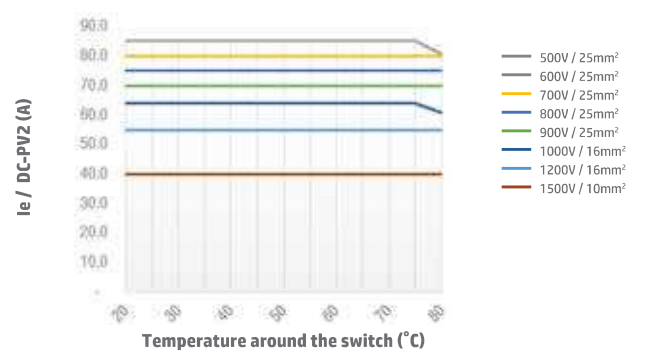

Note: SI55 3H pole configuration and SI65, DC-PV2 derating graphs can be supplied upon request. Please contact IMO for more information.

## Dimensions (mm)

SI16PM / SI25PM / SI32PM / SI38PM  
2

2H, 4

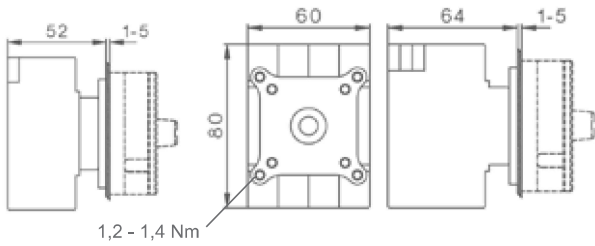

SI16PM / SI25PM / SI32PM / SI38PM  
6, 3H, 8, 4H

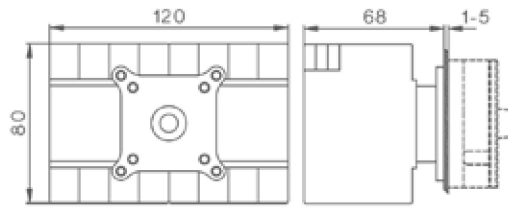

SI + X "Y"  
Extended Switch Shaft

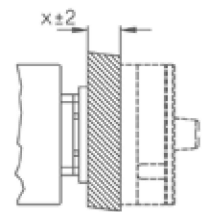

SI40PM / SI55PM / SI65PM  
2, 2H, 4

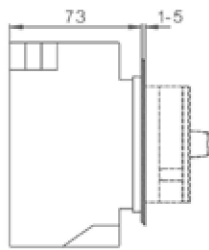
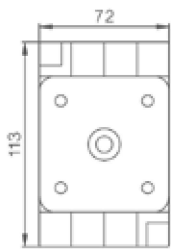

SI40PM / SI55PM / SI65PM  
6, 3H, 8, 4H

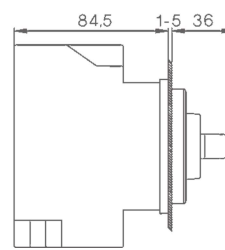
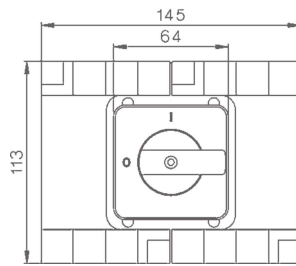

Mounting Hole

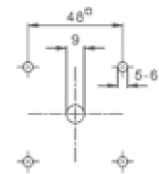

Escutcheon Plate 64  
Lever

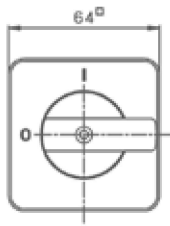

Lockable Lever

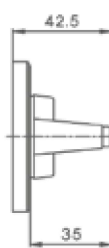
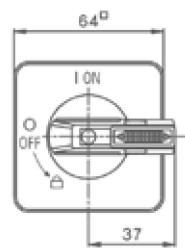

Lockable Rotary



Panel Mounting

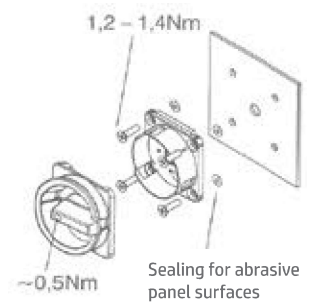

SI16SHM(L) / SI25SHM(L) / SI32SHM(L) / SI38SHM(L)  
2

2H, 4

Mounting Hole

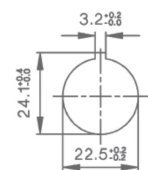
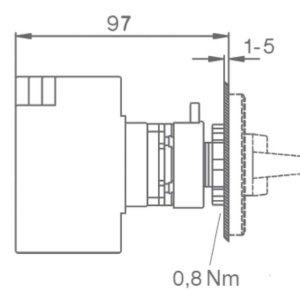
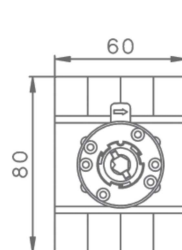
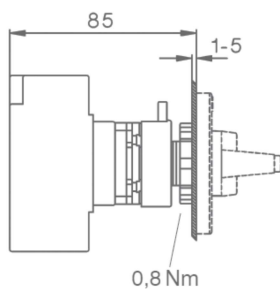
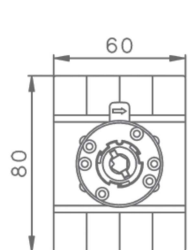

Escutcheon Plate 48  
Lever Handle

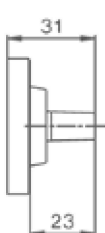
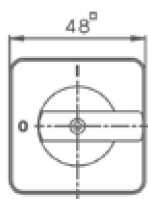

Lockable Lever

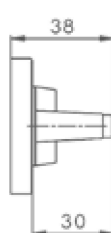
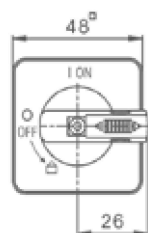

## Dimensions (mm) continued

SI16SHM(L) / SI25SHM(L) / SI32SHM(L) / SI38SHM(L)  
6, 3H, 8, 4H

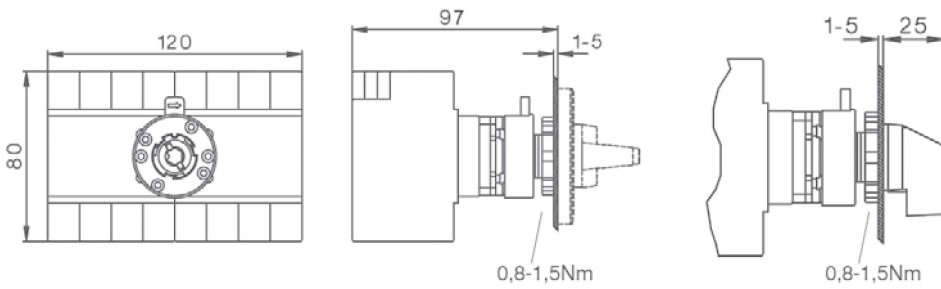

SI16BMDC / SI25BMDC / SI32BMDC / SI38BMDC  
2H, 4

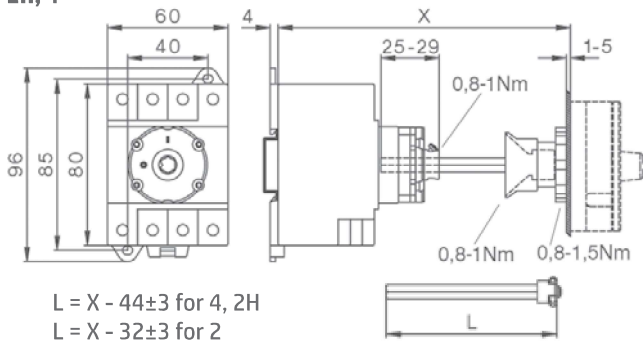

delivered with: 2H, 4  
 $X_{max.} = 194$ ,  $L = 150$   
 $(X_{min.} = 89)$

delivered with: 2  
 $X_{max.} = 182$ ,  $L = 150$   
 $(X_{min.} = 77)$

Greater X-Dimensions on request

$L = X - 44 \pm 3$  for 4, 2H  
 $L = X - 32 \pm 3$  for 2

SI16BMDC / SI25BMDC / SI32BMDC / SI38BMDC  
6, 3H, 8, 4H

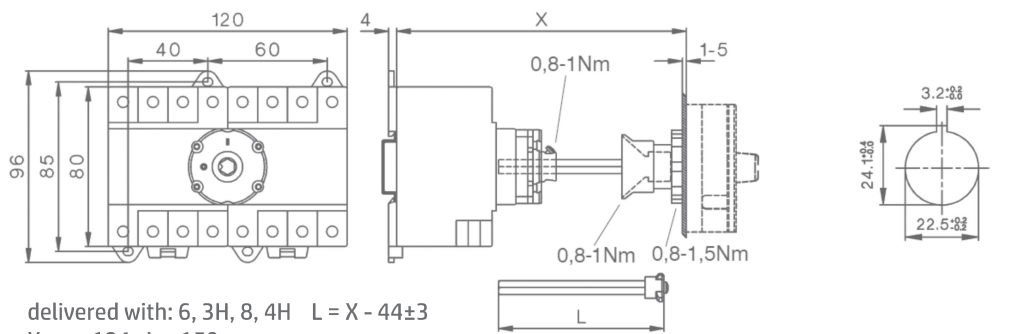

delivered with: 6, 3H, 8, 4H  $L = X - 44 \pm 3$   
 $X_{max.} = 194$ ,  $L = 150$   
 $(X_{min.} = 95)$

SI40BMDC / SI55BMDC / SI65BMDC  
2, 2H, 4

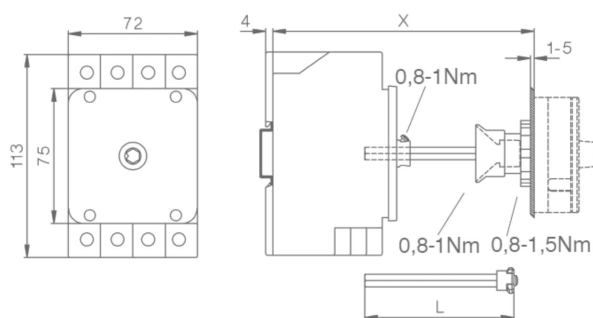

delivered with: 2, 2H, 4  $L = X - 61 \pm 3$   
 $X_{max.} = 194$ ,  $L = 133$   
 $(X_{min.} = 103)$

SI40BMDC / SI55BMDC / SI65BMDC  
6, 3H, 8, 4H

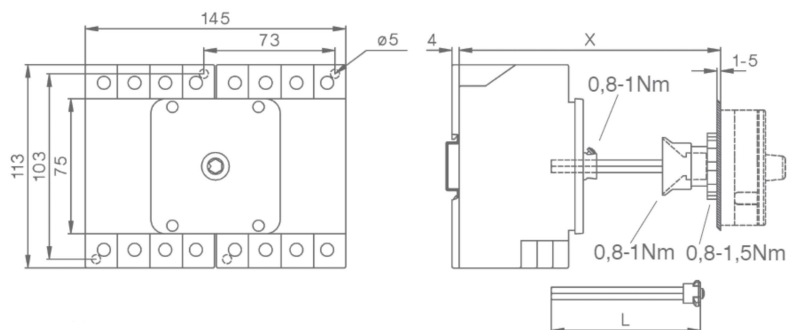

delivered with: 6, 3H, 8, 4H  $L = X - 73 \pm 3$   
 $X_{max.} = 194$ ,  $L = 121$   
 $(X_{min.} = 113)$

## Dimensions (mm) continued

SI16DB(L) / SI25DB(L) / SI32DB(L) / SI38DB(L)

2

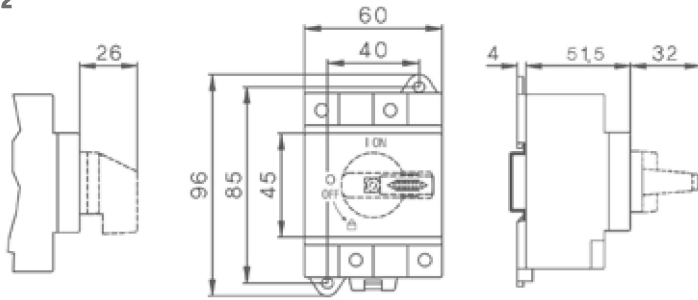

2H, 4

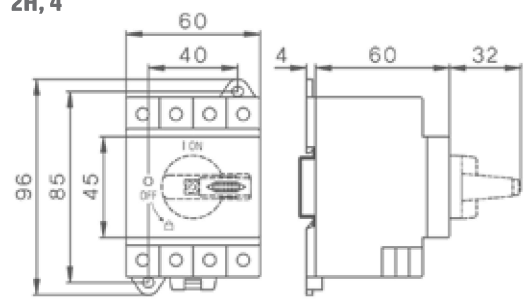

SI40DB(L) / SI55DB(L) / SI65DB(L)

2, 2H, 4

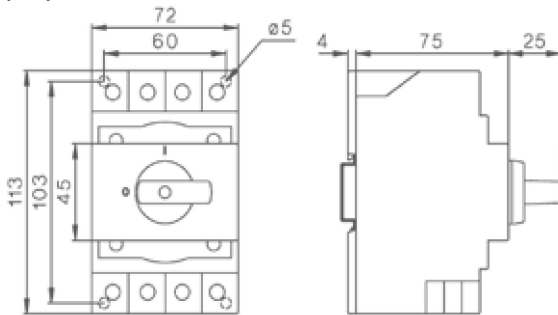

SI40DB(L) / SI55DB(L) / SI65DB(L)

6, 3H, 8, 4H

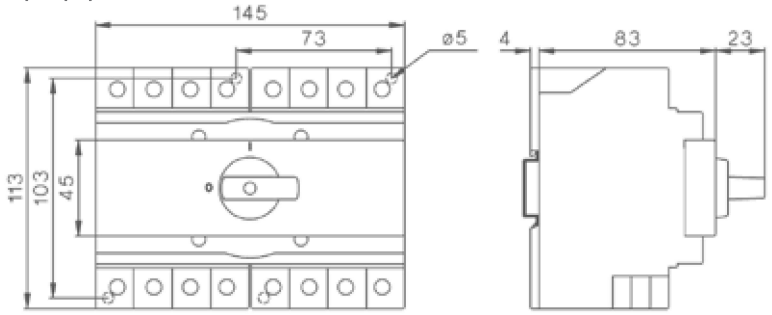

SI16DB(L) / SI25DB(L) / SI32DB(L) / SI38DB(L)

6, 3H, 8, 4H

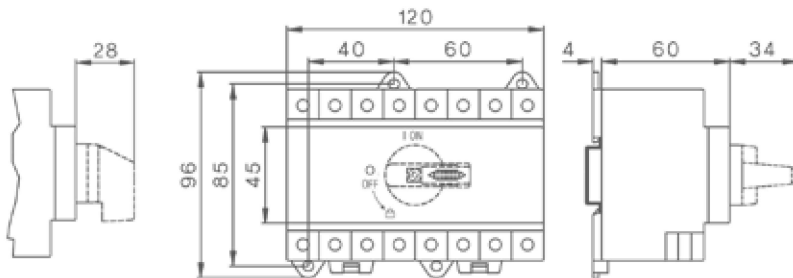

SI.. DBL with low height handle

2-LH

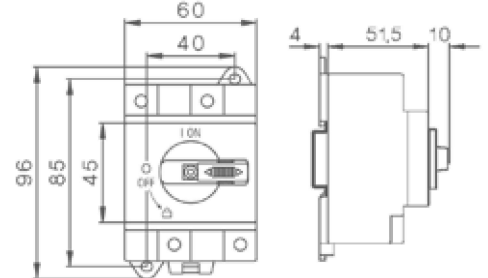

SI16DBL / SI25DBL / SI32DBL / SI38DBL with low height handle

2H-LH, 4-LH

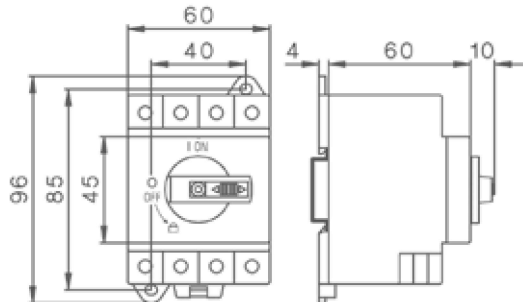

6-LH, 3H-LH, 8-LH, 4H-LH

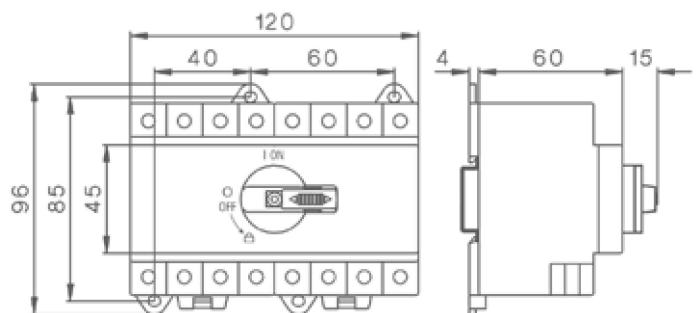

## Dimensions (mm) continued

SI16PEL / SI25PEL / SI32PEL / SI38PEL  
2, 2H, 4

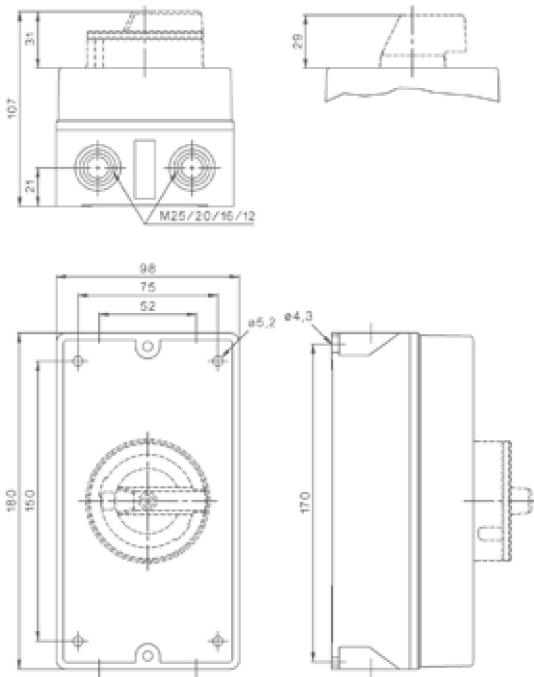

SI16PEL / SI25PEL / SI32PEL / SI38PEL  
2, 2H, 4 + M25

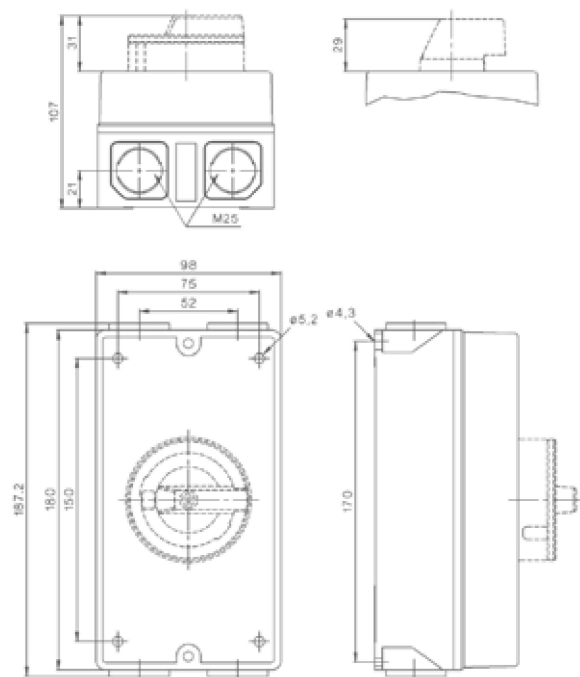

SI16PEL / SI25PEL / SI32PEL / SI38PEL  
6, 8, 3H, 4H

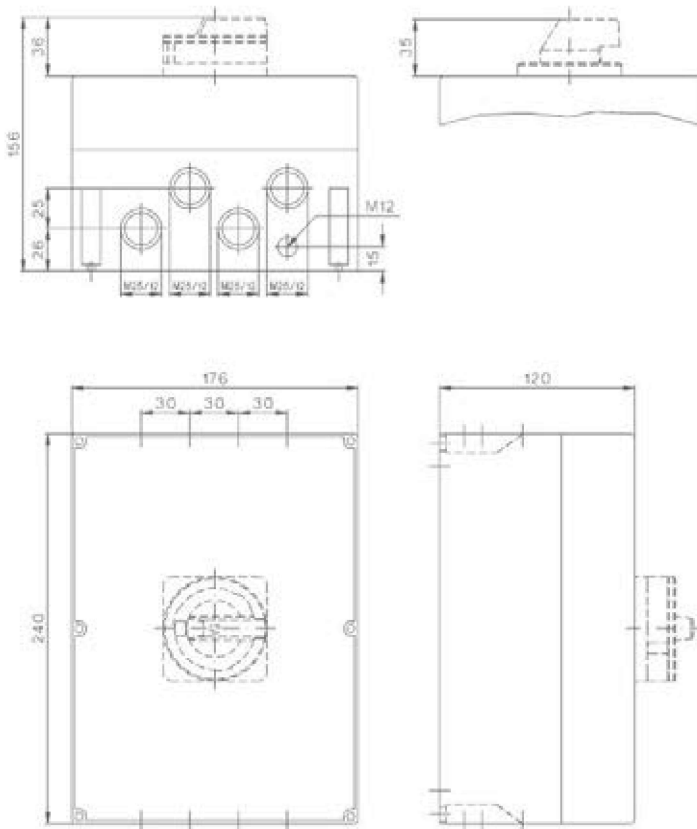

SI40PEL / SI55PEL / SI65PEL  
2, 2H, 4

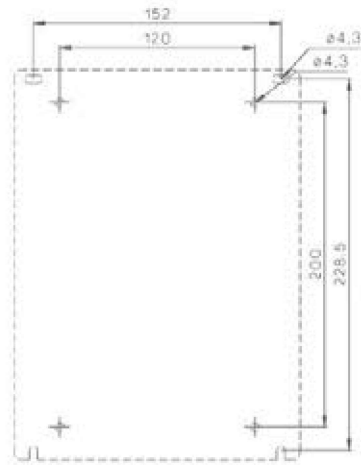

## Jumper Applications

SI16.. / SI25.. /  
SI32.. / SI38..  
2H

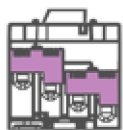

2x SIV-B1-1N

SI16.. / SI25.. / SI32..  
4T



SI38..  
4T



SI16.. / SI25.. /  
SI32.. / SI38..  
4H



4x SIV-B1-1N

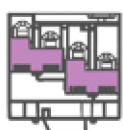
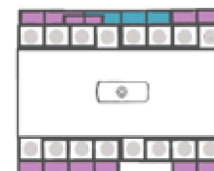
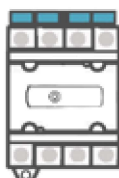
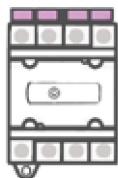
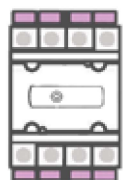

2x SIV-B1-1N



2x SIV-B1-1N

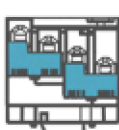

2x SIV-B1-2N

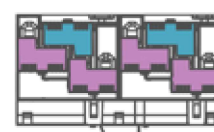

2x SIV-B1-2N

4x SIV-B1-1N

SI40.. / SI55.. / SI65..  
2H



2x SIV-B2-1N

SI40.. / SI55.. / SI65..  
4T



SI40.. / SI55.. / SI65..  
4H



4x SIV-B2-1N

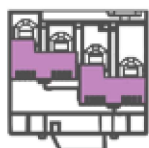
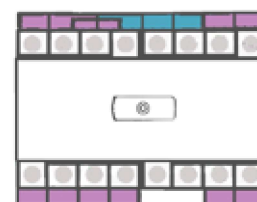
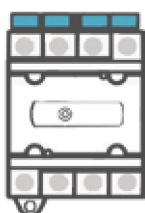
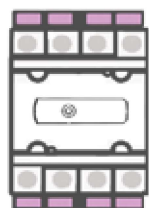

2x SIV-B2-1N

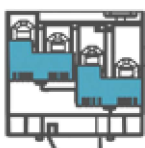

2x SIV-B2-2N

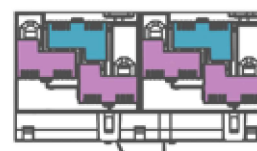

2x SIV-B2-2N

4x SIV-B2-1N