

**Rigid walls and flexible walls**

Wall thickness	≥ 100mm
Ø cable	OD ≤ Ø 21 mm
Cable loading	0% to 100%
Opening size	118mm x 105mm
Performance	EI 90 / E 120
Fire resistance	EN 1366-3
Classification	EN 13501-2

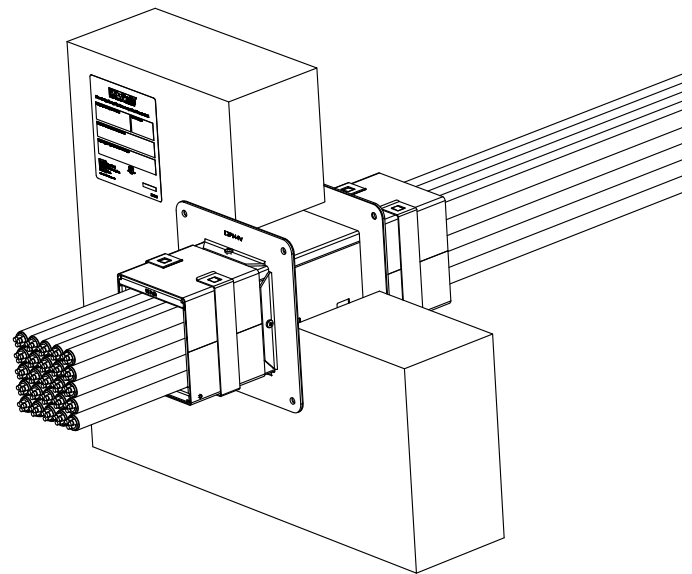

Not at scale. Units in millimeters  
Please refer to the CM350700 Installation Sheet.

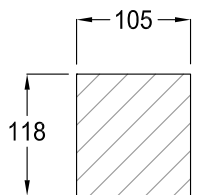
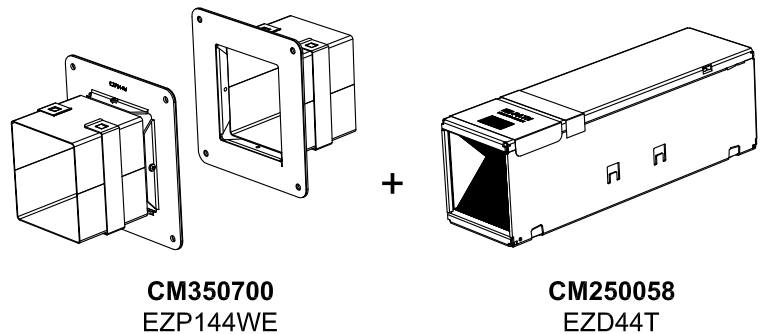
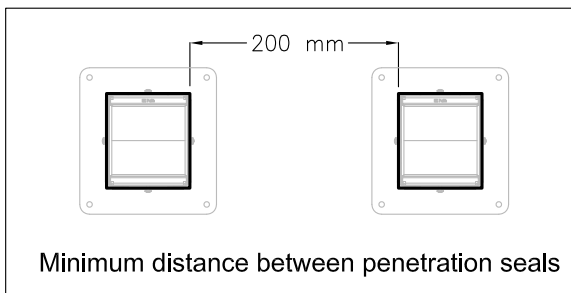

Opening size

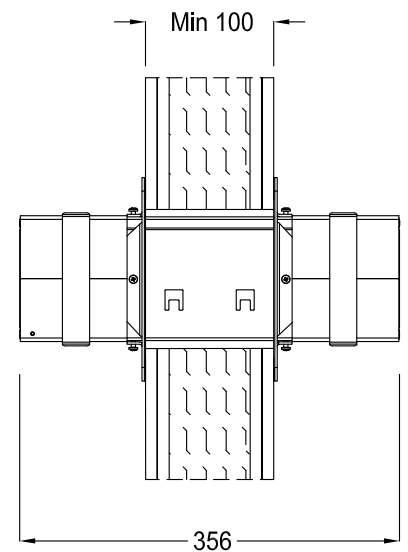
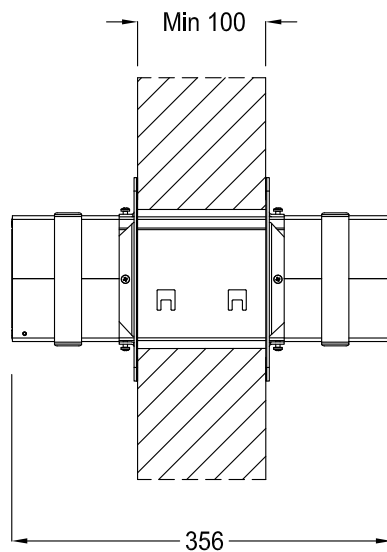
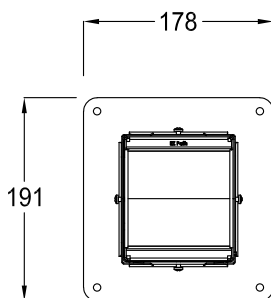

**Rigid walls**

Wall thickness	≥ 150mm
Ø cable	Telecommunication cables OD ≤ Ø 21 mm
Cable loading	0% to 100%
Opening size	Ø 152 mm - Ø 155 mm
Performance	EI 120
Fire resistance	EN 1366-3
Classification	EN 13501-2

Not at scale. Units in millimeters

Please refer to the CM350700 Installation Sheet.

