

110V AC 25 Metre BC Festoon Kit

Product Ref: **25MFKBC**

Technical Features:

- IP44 rated
- 110V AC 50/60Hz input voltage
- 25 metres x 2.5mm² 2 core PVC power cable lighting string
- 10 x BC type lamp holders (2m spaced)
- 10 x plastic lamp guards
- Lamp maximum 60W
- Complete with 16A 2P+E 110V EN 60309 (BS 4343) plug
- Lamps not included

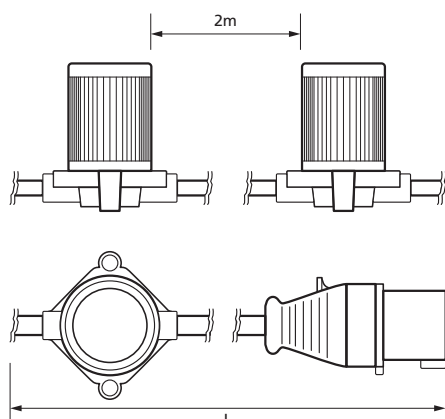

Product Specification

Voltage Rating	110V AC
IP Rating	IP44
Weight	3.420 kg
Colour	Yellow/Black
Cable Colour	Yellow
Cable Diameter	2.5mm ²
Distance Between Lampholders	2000mm (2 metres)
Lampholder Type	BC / B22
Available Options	BC and ES Options Available
Number of Lamp Holders	10
Compliance	CE, UKCA, RoHS
Guarantee	1 Year
Supplied with	10 x Lamp Holders, 10 x Plastic Guards and a 16A 2P+E 110V Plug IP44
Length	25m

Errors and omissions excepted (E&OE). All information is subject to change without notice and is correct at the time of print. Refer to issue number and date below.

Tel: +44 (0)1302 342 642 • mcg.co.uk • [@mcg_industrial](https://twitter.com/mcg_industrial)