

110V AC 25 Metre Festoon Kit

Product Ref: **25MFKESLPK**

Technical Features:

- IP44 rated
- 110V AC 50/60Hz input voltage
- 25 metres x 2.5mm², 2 core PVC power cable lighting string
- 10 x ES type lamp holders (2m spaced)
- Complete with 16A 2P+E 110V EN 60309 (BS 4343) plug
- Supplied with: 10 x plastic lamp guards
10 x 9.5W Polycarbonate Fusion LED GLS
ES lamps (806 lumens each)
Polycarbonate LED lamps remove the risk of broken glass

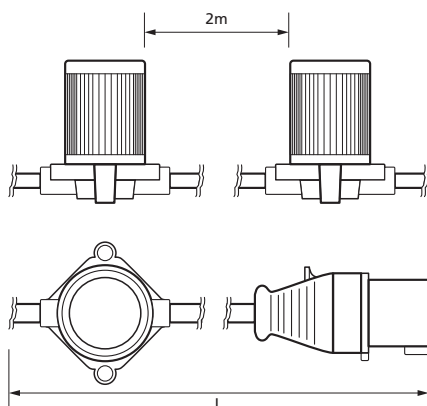

Product Specification

Voltage Rating	110V AC
IP Rating	IP44
Weight	4.000kg
Colour	Yellow/Black
Cable Colour	Yellow
Cable Diameter	2.5mm ²
Distance Between Lampholders	2000mm (2 metres)
Lampholder Type	ES / E27
Number of Lamp Holders	10
Lumens per Lamp	806lm
Compliance	CE, UKCA, RoHS
Guarantee	1 Year
Supplied with	10 x Plastic Yellow Lamp Guards 10 x 9.5W GLS ES Lamps (806 lumens each)
Length	25m

Errors and omissions excepted (E&OE). All information is subject to change without notice and is correct at the time of print. Refer to issue number and date below.

Tel: +44 (0)1302 342 642 • mcg.co.uk • @mcg_industrial