

## Connecting Bar 2 Pin 100A 28 Module

Product Ref: **CBP100A2PIN**

### Technical Features:

- Designed to be connected to the MCG Industrial range of products
- Pin style connection

## Product Specification

Voltage Rating	240V / 415V
Current Rating	100A
Weight	0.631kg
Number of Poles	Double Pole
Number of ways	28
Insulated	Yes
Colour	White
Material	Copper / Plastic
Compliance	UKCA, CE
Guarantee	1 Year
Standards	IEC 60898
Height	20mm
Length	1000mm
Width	22mm

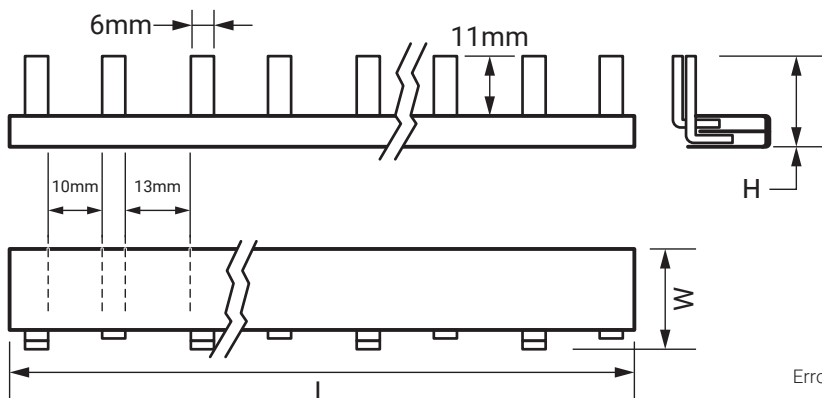
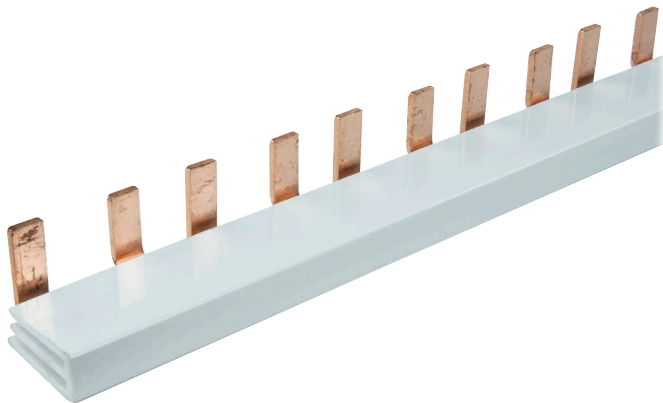

Errors and omissions excepted (E&OE). All information is subject to change without notice and is correct at the time of print. Refer to issue number and date below.

Tel: +44 (0)1302 342 642 • [mcg.co.uk](http://mcg.co.uk) • [✉@mcg\\_industrial](mailto:✉@mcg_industrial)