

10kVA Three Phase Portable Tool Transformer 110V with 4 x 16A and 2 x 32A Sockets

Product Ref: **CM10K36**

Technical Features:

- 7000VA Continuous rating
- 10kVA Tool rating
- Centre tapped to Earth
- Supplied with 4 x 16A and 2 x 32A 2P+E Sockets
- All sockets have MCB protection as standard
- Floor standing only



Product Specification

Continuous Rating	7000VA
Tool Rating	10kVA
Input Voltage	400/415V AC
Output Voltage	110V AC
Frequency	50/60Hz
Output Sockets (Total)	6
Output Socket Type	IP44 16A and 32A CEE Sockets
Output Socket Rating (Amps)	4 X 16A, 2 X 32A
Class	Class I
IP Rating	IP44
Enclosure Material	Steel
Colour	Orange/Yellow
Compliance	UKCA, CE
Standards	BS EN IEC 61558-1/2-23
Guarantee	1 Year
Weight	80.000kg
Depth	490mm
Height	770mm
Width	535mm

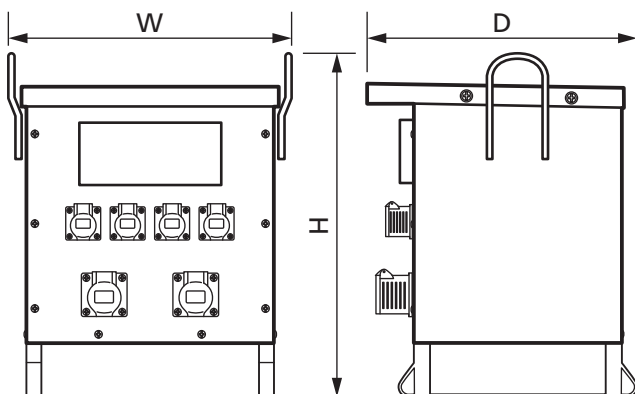

Errors and omissions excepted (E&OE). All information is subject to change without notice and is correct at the time of print. Refer to issue number and date below.

Tel: +44 (0)1302 342 642 • mcg.co.uk • [@mcg_industrial](https://twitter.com/mcg_industrial)