

## 32A 3P+N+E 415V

Interlocked Switched Socket IP44

Product Ref: **CX325P415SIS**

### Technical Features:

- Suitable for small commercial and industrial applications
- Conforms to IEC/EN 60309-1/2/4
- Corrosion and impact resistant
- Colour coded for fast identification of operating voltage
- Safe and reliable
- Padlockable handle



## Product Specification

Voltage Rating	415V
Current Rating	32A
IP Rating	IP44
Weight	0.701kg
Frequency	50/60Hz
Number of Poles	3P+N+E
Mounting	Wall - Horizontal
Fixing Centres	128mm x 103mm
Cable Entry	M20/M25 Knockout Entries
Supplied With	M20 and M25 compression Glands
Operating Temperature Range	-25 - +40°C
Terminal Size	4 - 16mm <sup>2</sup>
Isolator	Yes
Colour	Red
Material	Thermoplastic
UV Resistant	Yes
Compliance	UKCA, CE
Guarantee	1 Year
Standards	IEC/EN 60309-1/2/4
Depth	120.5mm
Height	120mm
Width	167mm

Torque Settings	
Socket Terminals	1.2Nm
Isolator Switch and Earth Terminal Bar	1.2Nm

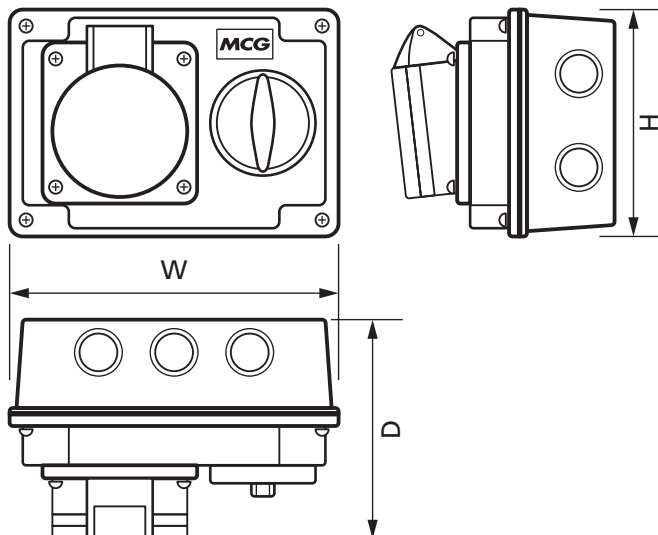

Errors and omissions excepted (E&OE). All information is subject to change without notice and is correct at the time of print. Refer to issue number and date below.

Tel: +44 (0)1302 342 642 • mcg.co.uk • @mcg\_industrial