

20W USB Rechargeable Portable LED Work Light and Power Bank

Product Ref: **CXFLR20**

Technical Features:

- Rechargeable Li-ion battery with battery level indicator
- 3 Lumen settings for prolong operation: 1600lm (100%), 800lm (50%) or 400lm (25%)
- Battery pack can also be used as a USB power bank
- Robust polycarbonate housing and arm
- IP54 dust and water resistant
- Strong magnetic body
- USB charging cable included



Product Specification

Wattage	20W
IP Rating	IP54
Weight	0.500kg
Charging Port	Micro USB
Cable Length	500mm
Charger Time	7 hours
Working Time	3 to 12 hours
USB Output	5V 1A
Input Voltage	DC 5V 1A
Operating Temperature	0° to +40°
Battery	3.7V 5.2Ah
Battery Type	Lithium-Ion
Mounting	Magnetic Rear Plate
Colour Temperature	6500K
Lumens	1600lm
Beam Angle	120°
Average Life	25000 hours
Colour	Black/Yellow
Material	Polycarbonate
Supplied With	USB 5V 1A Micro USB
Class	Class III
Compliance	UKCA, CE
Guarantee	1 Year
Standards	EN 60598, EN 62471, EN 62493
Depth	46mm
Height	127mm
Width	172mm

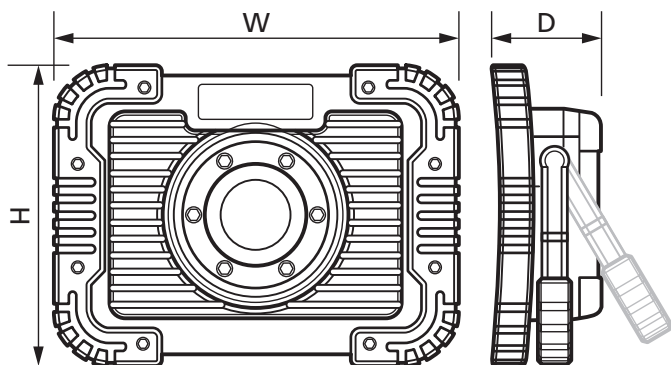

Errors and omissions excepted (E&OE). All information is subject to change without notice and is correct at the time of print. Refer to issue number and date below.

Tel: +44 (0)1302 342 642 • mcg.co.uk • [@mcg_industrial](https://twitter.com/mcg_industrial)