

## 16A 2P+E 110V Wall Mount Appliance Inlet IP44 c/w 20mm Gland

Product Ref: **CXN163P110AIWP**

### Technical Features:

- Manufactured from thermoplastic - suitable for general use
- Conforms to IEC/EN 60309-1/2
- Fast and simple assembly and wiring, cuts time and costs
- Corrosion and impact resistant
- Colour coded for fast identification of operating voltage
- Safe and reliable
- Typical operating temperature -25°C to 50°C
- Screwless cable grip

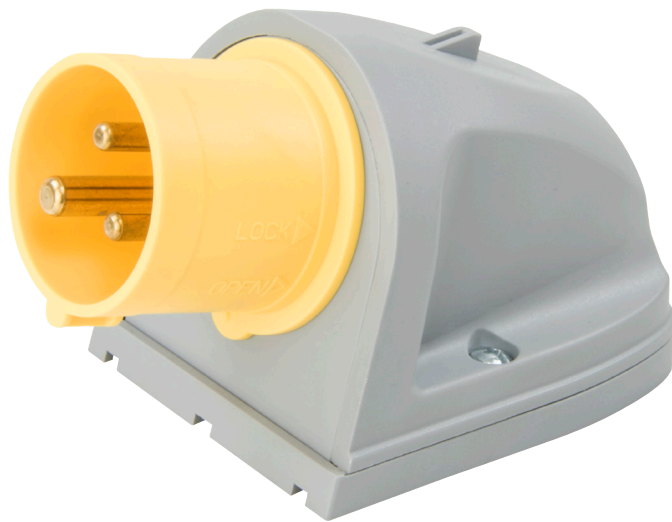

## Product Specification

Voltage Rating	110V
Current Rating	16A
IP Rating	IP44
Weight	0.150kg
Frequency	50Hz
Number of Poles	2P+E
Terminal size (Range)	1.5 - 4mm <sup>2</sup>
Torque	0.8Nm
Mounting	Wall
Cable Entry	Top Gland Entry - M20 x 1.5 Rear knockout
Clamping range (min - max)	10 - 14mm
Colour	Yellow
Material	Thermoplastic
Compliance	UKCA, CE
Guarantee	1 Year
Standards	IEC/EN 60309-1/2
Supplied With	IP Gland
Depth	74.5mm
Height	114mm
Width	74.5mm

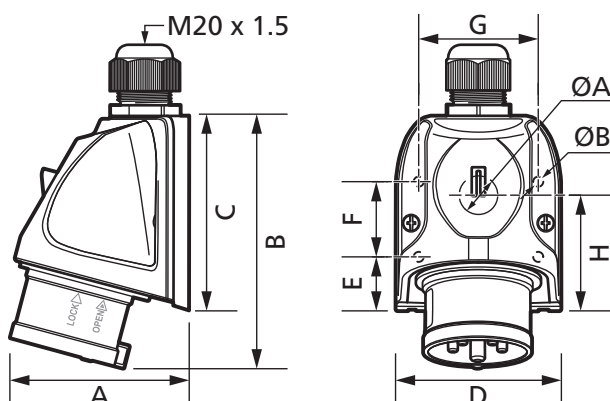

A	B	C	D	E
74.5mm	114mm	86mm	74.5mm	24.5mm
F	G	H	ØA	ØB
36mm	52mm	49mm	20mm	5mm

Errors and omissions excepted (E&OE). All information is subject to change without notice and is correct at the time of print. Refer to issue number and date below.

Tel: +44 (0)1302 342 642 • [mcg.co.uk](http://mcg.co.uk) • [@mcg\\_industrial](https://twitter.com/mcg_industrial)