

16A 2P+E 110V Coupler IP44

Product Ref: **CXN163P110C**

Technical Features:

- Manufactured from thermoplastic - suitable for general use
- Conforms to IEC/EN 60309-1/2
- Quick release feature
- Fast and simple assembly and wiring, cuts time and costs
- Ergonomic grip
- Corrosion and impact resistant
- Colour coded for fast identification of operating voltage
- Safe and reliable
- Typical operating temperature -25°C to +50°C
- Screwless cable grip



Product Specification

Voltage Rating	110V
Current Rating	16A
IP Rating	IP44
Weight	0.135kg
Frequency	50Hz
Number of Poles	2P+E
Terminal size (Range)	1 - 2.5mm ²
Torque	0.8Nm
Mounting	Trailing
Cable Entry	Compression Gland
Clamping range (min - max)	7 - 15.5mm
Colour	Yellow
Material	Thermoplastic
Compliance	UKCA, CE
Guarantee	1 Year
Standards	IEC/EN 60309-1/2
Diameter Ø	51mm
Height	77mm
Length	135mm

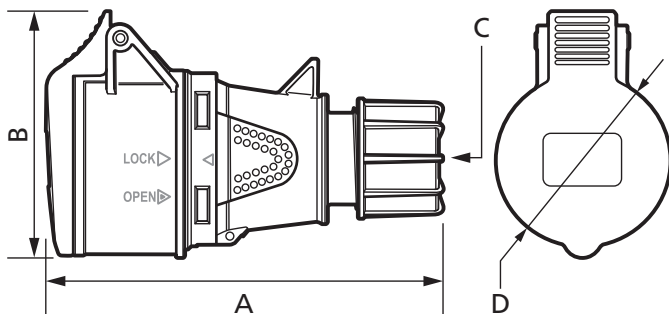

A	B	C	D
135mm	77mm	15.5mm	51mm

Errors and omissions excepted (E&OE). All information is subject to change without notice and is correct at the time of print. Refer to issue number and date below.

Tel: +44 (0)1302 342 642 • mcg.co.uk • @mcg_industrial