

16A 2P+E 240V Panel Mounted Angled Socket IP67

Product Ref: **CXN163P240PA67**

Technical Features:

- Manufactured from thermoplastic - suitable for general use
- Conforms to IEC/EN 60309-1/2
- Fast and simple assembly and wiring, cuts time and costs
- Corrosion and impact resistant
- Colour coded for fast identification of operating voltage
- Safe and reliable
- Complete with gasket
- Typical operating temperature -25°C to 50°C

Product Specification

Voltage Rating	230V
Current Rating	16A
IP Rating	IP67
Weight	0.145kg
Frequency	50Hz
Number of Poles	2P+E
Terminal size (Range)	1.5 - 4mm ²
Torque	0.8Nm
Mounting	Panel
Colour	Blue
Material	Thermoplastic
Compliance	UKCA, CE
Guarantee	1 Year
Standards	IEC/EN 60309-1/2
Supplied With	Gasket
Type	Angled
Depth	48.5mm
Height	81mm
Width	75.5mm

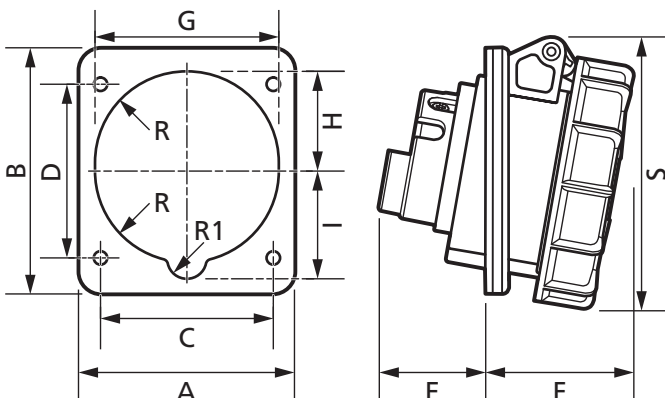

A	B	C	D	E	F
75.5mm	86.5mm	61mm	61mm	38.5mm	48.5mm
G	H	I	R	R1	S
64mm	35mm	38mm	32mm	7mm	81mm

Errors and omissions excepted (E&OE). All information is subject to change without notice and is correct at the time of print. Refer to issue number and date below.

Tel: +44 (0)1302 342 642 • mcg.co.uk • [@mcg_industrial](https://twitter.com/mcg_industrial)