

16A 3P+E 415V Panel Mounted Straight Socket IP67

Product Ref: **CXN164P415PS67**

Technical Features:

- Manufactured from thermoplastic - suitable for general use
- Conforms to IEC/EN 60309-1/2
- Fast and simple assembly and wiring, cuts time and costs
- Corrosion and impact resistant
- Colour coded for fast identification of operating voltage
- Safe and reliable
- Complete with gasket
- Typical operating temperature -25°C to +50°C

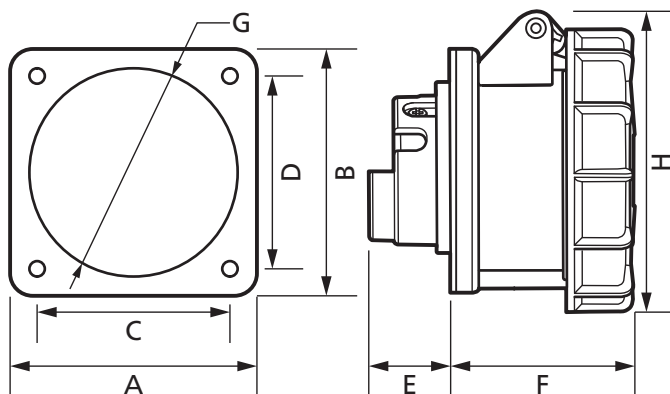

Product Specification

Voltage Rating	415V
Current Rating	16A
IP Rating	IP67
Weight	0.167kg
Frequency	50Hz
Number of Poles	3P+E
Terminal size (Range)	1.5 - 4mm ²
Torque	0.8Nm
Mounting	Panel
Colour	Red
Material	Thermoplastic
Compliance	UKCA, CE
Guarantee	1 Year
Standards	IEC/EN 60309-1/2
Supplied With	Gasket
Type	Straight
Depth	54.5mm
Height	85mm
Width	75mm

A	B	C	D
75mm	75mm	60mm	60mm
E	F	G	H
26.3mm	54.5mm	64mm	85mm

Errors and omissions excepted (E&OE). All information is subject to change without notice and is correct at the time of print. Refer to issue number and date below.

Tel: +44 (0)1302 342 642 • mcg.co.uk • [@mcg_industrial](https://twitter.com/mcg_industrial)