

32A 2P+E 110V Coupler IP44

Product Ref: **CXN323P110C**

Technical Features:

- Manufactured from thermoplastic - suitable for general use
- Conforms to IEC/EN 60309-1/2
- Quick release feature
- Fast and simple assembly and wiring, cuts time and costs
- Ergonomic grip
- Corrosion and impact resistant
- Colour coded for fast identification of operating voltage
- Safe and reliable
- Typical operating temperature -25°C to +50°C
- Screwless cable grip

Product Specification

Voltage Rating	110V
Current Rating	32A
IP Rating	IP44
Weight	0.230kg
Frequency	50Hz
Number of Poles	2P+E
Terminal size (Range)	4 - 10mm ²
Torque	1.2Nm
Mounting	Trailing
Cable Entry	Compression Gland
Clamping range (min - max)	11 - 22mm
Colour	Yellow
Material	Thermoplastic
Compliance	UKCA, CE
Guarantee	1 Year
Standards	IEC/EN 60309-1/2
Diameter Ø	67mm
Height	96mm
Length	167mm

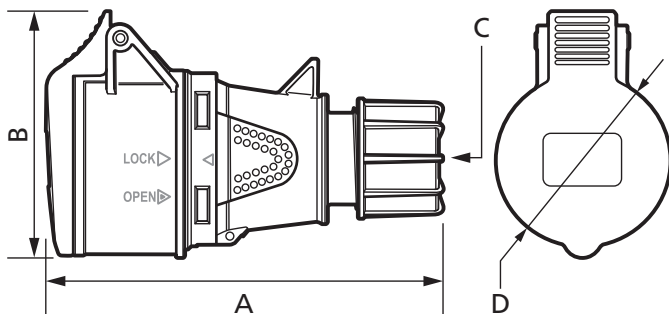

A	B	C	D
167mm	96mm	20mm	67mm

Errors and omissions excepted (E&OE). All information is subject to change without notice and is correct at the time of print. Refer to issue number and date below.

Tel: +44 (0)1302 342 642 • mcg.co.uk • @mcg_industrial