

32A 2P+E 110V Wall Socket IP67 c/w 25mm Gland

Product Ref: **CXN323P110W67A**

Technical Features:

- Manufactured from thermoplastic - suitable for general use
- Conforms to IEC/EN 60309-1/2
- Fast and simple assembly and wiring, cuts time and costs
- Corrosion and impact resistant
- Colour coded for fast identification of operating voltage
- Safe and reliable
- Typical operating temperature -25°C to +50°C
- Screwless cable grip



Product Specification

Voltage Rating	110V
Current Rating	32A
IP Rating	IP67
Weight	0.392kg
Frequency	50Hz
Number of Poles	2P+E
Terminal size (Range)	2.5 - 10mm ²
Torque	1.2Nm
Mounting	Wall
Cable Entry	Top Gland Entry - M25 x 1.5 Rear knockout
Clamping range (min - max)	13 - 18mm
Colour	Yellow
Material	Thermoplastic
Compliance	UKCA, CE
Guarantee	1 Year
Standards	IEC/EN 60309-1/2
Supplied With	25mm Gland
Depth	114mm
Height	156.5mm
Width	105mm

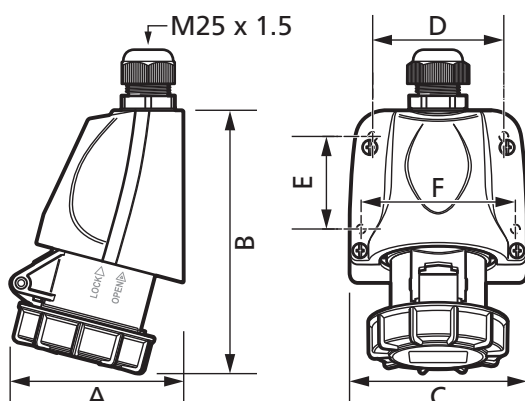

A	B	C
114mm	156.5mm	105mm
D	E	F
78mm	43mm	92mm

Errors and omissions excepted (E&OE). All information is subject to change without notice and is correct at the time of print. Refer to issue number and date below.

Tel: +44 (0)1302 342 642 • mcg.co.uk • [@mcg_industrial](https://twitter.com/mcg_industrial)