

## 32A 3P+E 415V Wall Mount Appliance Inlet IP44 c/w 25mm Gland

Product Ref: **CXN324P415AIWP**

### Technical Features:

- Manufactured from thermoplastic - suitable for general use
- Conforms to IEC/EN 60309-1/2
- Fast and simple assembly and wiring, cuts time and costs
- Corrosion and impact resistant
- Colour coded for fast identification of operating voltage
- Safe and reliable
- Typical operating temperature -25°C to 50°C
- Screwless cable grip

### Product Specification

Voltage Rating	415V
Current Rating	32A
IP Rating	IP44
Weight	0.257kg
Frequency	50Hz
Number of Poles	3P+E
Terminal size (Range)	2.5 - 10mm <sup>2</sup>
Torque	1.2Nm
Mounting	Wall
Cable Entry	Top Gland Entry - M25 x 1.5 Rear knockout
Clamping range (min - max)	13 - 18mm
Colour	Red
Material	Thermoplastic
Compliance	UKCA, CE
Guarantee	1 Year
Standards	IEC/EN 60309-1/2
Supplied With	IP Gland
Depth	91.5mm
Height	140mm
Width	100mm

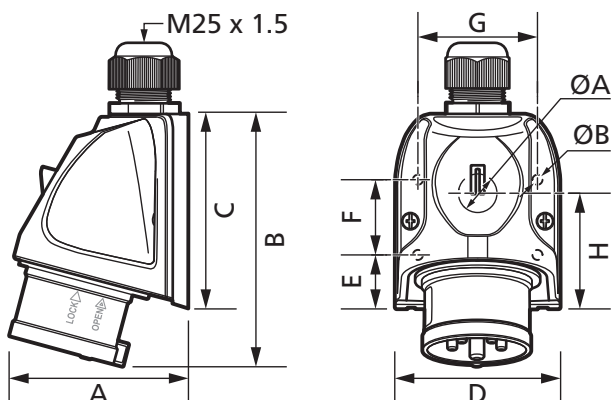

A	B	C	D	E
91.5mm	140mm	100mm	85mm	26.5mm
F	G	H	ØA	ØB
40mm	60mm	59.5mm	20mm	5mm

Errors and omissions excepted (E&OE). All information is subject to change without notice and is correct at the time of print. Refer to issue number and date below.

Tel: +44 (0)1302 342 642 • [mcg.co.uk](http://mcg.co.uk) • [@mcg\\_industrial](https://twitter.com/mcg_industrial)