

110V 4 Way Site Extension Splitter Box **Product Specification** c/w 4 x 16A 110V 2P+E Panel Sockets

Product Ref: **EOU1415**

Technical Features:

- 110V AC 50/60Hz input voltage
- 16A maximum input
- 4 x 16A 2P+E 110V EN 60309 (BS 4343) power sockets
- Steel powder coated body
- Carrying handle
- Fitted with 5m power cable
- Complete with 16A 2P+E 110V EN 60309 (BS 4343) plug



| | |
|-------------------|---|
| Voltage Rating | 110V |
| Current Rating | 16A |
| IP Rating | IP44 |
| Weight | 2.445kg |
| Cable Length | 5m |
| Cable Size | 1.5mm ² |
| Frequency | 50/60Hz |
| Socket Type | 16A 2P+E 110V |
| Number of Outlets | 4 |
| Mounting | Free Standing |
| Colour | Yellow |
| Material | Powder Coated Steel |
| Supplied With | 4 x 16A 2P+E 110V power sockets 1 x 16A 2P+E 110V plug 5m power cable |
| Compliance | UKCA, CE, RoHS |
| Guarantee | 1 Year |
| Standards | EN 60309 |
| Depth | 173mm |
| Height | 240mm |
| Width | 245mm |

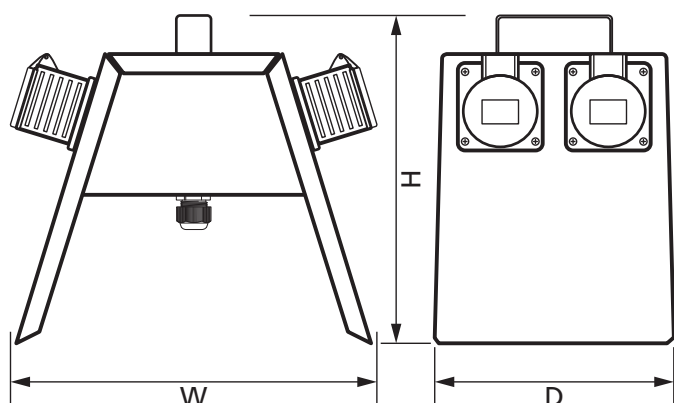

Errors and omissions excepted (E&OE). All information is subject to change without notice and is correct at the time of print. Refer to issue number and date below.

Tel: +44 (0)1302 342 642 • mcg.co.uk • [X@mcg_industrial](mailto:info@mcg_industrial)