

24 Hour 7 Day Single Channel 1 Module Digital DIN Rail Timer

Product Ref: **MCGT80C**

Technical Features:

- 24 hour or 7 day programming
- 6 ON and 6 OFF programmes
- Minimum 1 minute switching time
- 100 hours battery backup
- Volt free contacts
- Load rating: 16A resistive (2A inductive)
- Ideal for heating, lighting and security applications

Product Specification

Voltage Rating	230V
Switching Rating	16A
Load Rating (Inductive)	2A
Programming Type	24 Hour / 7 Day
Weight	0.073kg
Frequency	50Hz
Number of Modules	1
Number of Channels	1
Mounting	DIN Rail
Colour	Light Grey
Material	Plastic
Compliance	UKCA, CE
Guarantee	1 Year
Standards	EN 60730-1:2011, EN 60730-2-7:2010
Depth	61mm
Height	90mm
Width	19mm

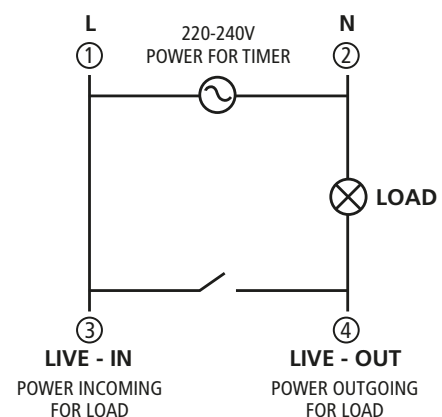
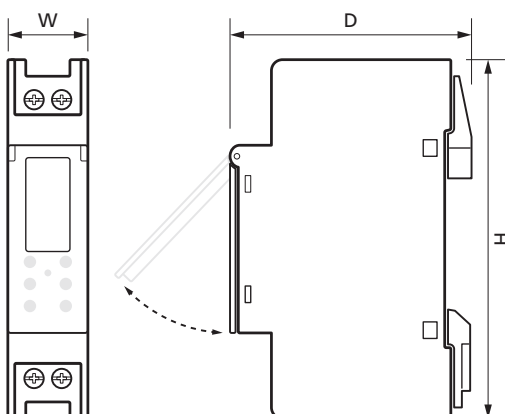

Errors and omissions excepted (E&OE). All information is subject to change without notice and is correct at the time of print. Refer to issue number and date below.

Tel: +44 (0)1302 342 642 • mcg.co.uk • [@mcg_industrial](https://twitter.com/mcg_industrial)