

Product Ref:

## MGU100616IP65

Metal Garage Unit IP65 with 100A Isolator plus 6A and 16A MCBs

Specification



### Features:

- Complete with fully fitted and pre-wired 2 pole 100A isolator device plus 1 x 6A MCB Type B and 1 x 16A MCB Type B
- Neutral and earth terminals, DIN rail, neutral cable and busbar included
- Fully enclosed metal construction body with drop-down metal cover and retaining clip. Raised keyholes for secure easy installation. Multiple circular cable entry knockouts (M20)
- Accessories pack plus a full set of self adhesive graphic or textural, warning and fixing date labels

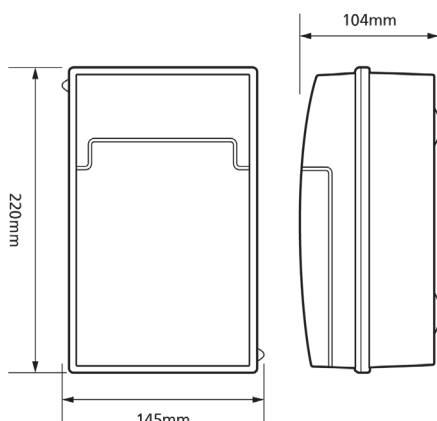

Voltage Rating	230V
Current Rating	100A
IP Rating	IP65
Weight	1.530kg
Width	145mm
Height	220mm
Depth	104mm
Number of Modules	4
Number of Outgoing ways	2
Cable Entry	Knockouts (M20 and M32)
Supplied With	2 x MCB's
Incoming Device	100A Isolator
Mounting	Surface
Colour	White
Finish	Polyester Powder Coated
Material	Steel
Compliance	CE
Guarantee	1 Year
Standards	BS 7671 Amendment 3:2015, BS EN 61439-3



Errors and omissions excepted (E&OE). All information is subject to change without notice and is correct at the time of print. Refer to issue number and date below.

Tel: +44 (0)1302 342 642 • mcg.co.uk • @mcg\_industrial