

Product Ref:

MMSB552MCB

5 + 5 + 2 Dual RCD High Integrity Metal Consumer Unit with 10 MCBs

Specification



Features:

- Supplied complete with fully fitted and pre-wired 2 pole 100A incoming isolator and 2 x 80A 30mA RCD devices, plus 10 x MCBs: 3 x 6A MCBs Type B, 2 x 16A MCBs Type B, 4 x 32A MCBs Type B and 1 x 40A MCB Type B
- Ferruled cable ends for secure connections
- Fully enclosed metal construction body with drop-down metal cover. Raised keyholes for secure easy installation
- Multiple circular cable entry knockouts (M25, M32 and M40) plus rear aperture/rounded cable entries
- BS 7671 Amendment 3:2015 and BS EN 61439-3 compliant

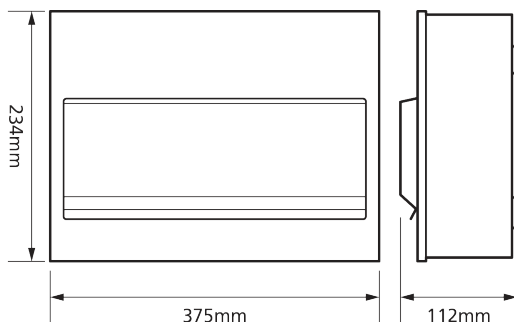

Voltage Rating	230V
Current Rating	100A
RCD Rating	80A
IP Rating	IP20
Weight	4.895kg
Width	375mm
Height	234mm
Depth	112mm
Incoming Device	100A Isolator
Number of Outgoing ways	12
Board Configuration	2 + 5 + 5
Cable Entry	Knockouts (M25, M32 and M40)
Supplied With	2 x RCD's and 10 x MCB's
Type	High Integrity
Mounting	Surface
Colour	White
Finish	Polyester Powder Coated
Material	Steel
Compliance	CE
Guarantee	1 Year
Standards	BS 7671 Amendment 3:2015, BS EN 61439-3

Errors and omissions excepted (E&OE). All information is subject to change without notice and is correct at the time of print. Refer to issue number and date below.