

Metal Consumer Unit IP65 with 63A RCD and 16A MCB

Product Ref: **MSU6316IP65**

Technical Features:

- Complete with fully fitted and pre-wired 2 pole 63A RCD device and a 16A MCB Type B
- Fully enclosed metal construction body with drop-down metal cover and retaining clip. Raised keyholes for secure easy installation. Retained screws
- Multiple circular cable entries (M20)
- Accessories pack plus a full set of self adhesive graphic or textural, warning and fixing date labels
- Split load neutral connections - prevents hot spots
- BS 7671 Amendment 3:2015 and BS EN 61439-3 compliant



Product Specification

Voltage Rating	230V
Current Rating	63A
RCD Rating	63A
IP Rating	IP65
Weight	1.630kg
Incoming Device	63A 30mA RCD
Number of Outgoing ways	2
Supplied With	1 x 63A 30mA 2 Pole RCD and 1 x 16A MCB Type B
Cable Entry	Knockouts (M20)
Mounting	Surface
Colour	White
Finish	Polyester Powder Coated
Material	Steel
Compliance	UKCA, CE
Guarantee	1 Year
Standards	BS 7671 Amendment 3:2015, BS EN 61439-3
Depth	104mm
Height	220mm
Width	145mm

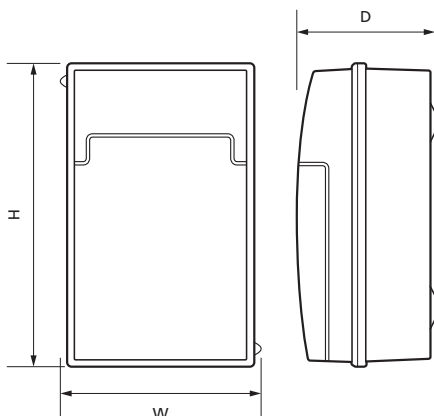

Errors and omissions excepted (E&OE). All information is subject to change without notice and is correct at the time of print. Refer to issue number and date below.

Tel: +44 (0)1302 342 642 • mcg.co.uk • [@mcg_industrial](https://twitter.com/mcg_industrial)