

## Metal Shower Unit IP65 with 63A RCD and 40A MCB

Product Ref: **MSU6340IP65**

### Technical Features:

- Complete with fully fitted and pre-wired RCD and MCB
- Fully enclosed metal construction body with drop-down metal cover and retaining clip. Raised keyholes for secure easy installation. Multiple circular cable entry knockouts (M20). Finished in white polyester powder coating to RAL9010
- Accessories pack includes glands, screw caps and blanking module plus a full set of self adhesive graphic or textural, warning and fixing date labels
- Split load neutral connections - prevents hot spots
- BS 7671 Amendment 3:2015 and BS EN 61439-3 compliant

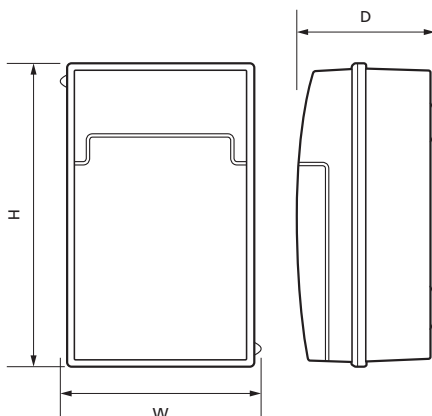

## Product Specification

Voltage Rating	230V
Current Rating	63A
RCD Rating	63A
IP Rating	IP65
Weight	1.460kg
Number of Outgoing ways	1
Cable Entry	Knockouts (M20)
Supplied With	1 x 63A 30mA 2 Pole RCD 1 x 40A MCB Type B
Incoming Device	63A 30mA RCD
Mounting	Surface
Colour	White
Finish	Polyester Powder Coated
Material	Steel
Compliance	UKCA, CE
Guarantee	1 Year
Standards	BS 7671 Amendment 3:2015, BS EN 61439-3
Depth	104mm
Height	220mm
Width	145mm

Errors and omissions excepted (E&OE). All information is subject to change without notice and is correct at the time of print. Refer to issue number and date below.

Tel: +44 (0)1302 342 642 • [mcg.co.uk](http://mcg.co.uk) • [@mcg\\_industrial](https://twitter.com/mcg_industrial)