

2 Module Single Phase and Neutral Type 2+3 Surge Protector in Plastic Enclosure **Product Specification**

Product Ref: **SY1-C40XPE**

Technical Features:

- Ideal for commercial applications
- Suitable for TN-C-S systems
- Compliant to 18th Edition Wiring Regulations (BS 7671:2018 Surge Protection)
- Enclosure made from thermo-resistant technopolymers (UV stabilised). High resistance to chemicals & weather
- Fire resistance: 650°C (Glow wire test)
- Not pre-wired (supplied with wiring instructions)
- Enclosure manufactured to EN 60670-1:2005 and EN 60670-22:2006 (European Standards)



IP Rating	IP20
Weight	0.518kg
Number of Modules	2
Mounting	Surface
Colour	Grey/Yellow
Finish	Smooth
Material	Technopolymers
Compliance	UKCA, CE
Guarantee	10 Years
Standards	BS 7671:2018, IEC 61643-1, EN 61643-11, EN 60670-1:2005, EN 60670-22:2006
Suitable for	TN-C-S systems
Type	2 + 3
Depth	92mm
Height	158mm
Width	118mm

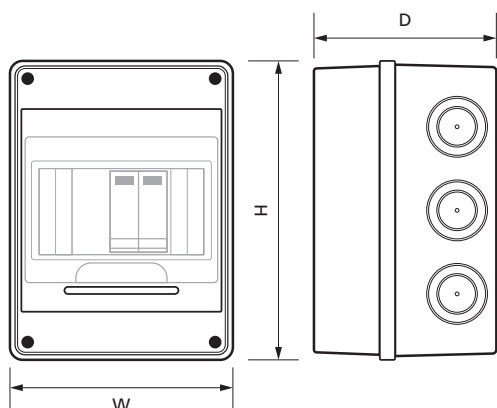

Errors and omissions excepted (E&OE). All information is subject to change without notice and is correct at the time of print. Refer to issue number and date below.

Tel: +44 (0)1302 342 642 • mcg.co.uk • [@mcg_industrial](https://twitter.com/mcg_industrial)