



DRI-ECO-HEAT-HC

Whole House Ventilation Unit with Hall Control

Installation & Maintenance

nuaire



1.0 SAFETY INFORMATION

- The provision of the electrical supply and the connection of the DRI-ECO-HEAT-HC unit to the mains must be carried out by a qualified electrician.
- Isolate from power supply before removing any covers. During installation/maintenance ensure all covers are fitted before switching on the mains supply.
- Means for disconnection must be incorporated in the fixed wiring as shown in the wiring diagram in accordance with IEE wiring or national wiring rules.
- In order to avoid a hazard due to inadvertent resetting of the thermal cut-out, this appliance must not be supplied through an external switching device, such as a timer, or connected to a circuit that is regularly switched on and off by the utility.
- The fan unit is supplied with a fused spur. The three core mains cable from the fan unit should be connected to a fixed wiring installation, via the spur, in accordance with current IEE wiring regulations.
- If the mains supply cord to the PSU is damaged, it must be replaced by the manufacturer, its service agent or similarly qualified persons in order to avoid a hazard.
- The heater unit must be connected to the ceiling vent and fan unit using the 3 looms that protrude from the heater module.
- Disconnection from mains must be incorporated within the fixed wiring and shall have a minimum contact separation of 3mm in accordance with latest edition of the wiring regulations.
- The CO2 sensor requires a 230V power supply. Remove the front panel as per the humidity sensor and release the terminal cover via a fixing lug on the rear of the sensor. Refer to the wiring diagram provided and connect the supply to the terminal box. Finally the sensor may be mounted to the wall (screws are not provided).
- It is important to ensure that the diffuser is NOT placed within 1 metre of a smoke alarm. If the diffuser cannot be repositioned, two sides of the diffuser must be closed off using the air dams supplied to encourage the air through the remaining open sides that faces at least 1.5 metres of unobstructed area away from the smoke alarm sensor.
- If the unit is required to switch off in the event of smoke/CO detection, alarms are available with separate relay bases from 3rd party companies. This is a mandatory requirement for all units installed in a 3 Storey property.
- The flexible duct (maximum length 2m) is connected to the base unit by inserting the duct over the outlet duct and held in place using the supplied cable tie.
- When installing the duct to the heater unit, insert the duct over the back of the heater, over the protruding screw heads (3mm from the face of the duct) and fasten the cable tie below the screws. This ensures that the duct will be held on securely, check all duct joints are air tight.
- Precautions must be taken to avoid the back-flow of gases into the room from the open flue of gas or other fuel-burning appliances.

- This appliance can be used by children aged from 8 years and above and persons with reduced physical, sensory or mental capabilities or lack of experience and knowledge if they have been given supervision or instruction concerning use of the appliance in a safe way and understand the hazards involved. Children shall not play with the appliance. Cleaning and user maintenance shall not be made by children without supervision.

2.0 INTRODUCTION

The DRI-ECO-HEAT-HC provides whole home ventilation using the Positive Input Ventilation principle. The concept is to introduce fresh, filtered air into the dwelling at a continuous rate, encouraging movement of air from inside to outside. To achieve this the unit is mounted in the loft space, drawing air through the filters and inputting it, at ceiling level, into the property.

The DRI-ECO-HEAT-HC fan unit includes an internal sensor to regulate the fan speed according to the temperature of the loft. The internal sensor is to increase airflow to the dwelling when the loft is warmer than the house. The units 'Fixed Temperature Heat Recovery' strategy shall be achieved via a sensor located in the unit and shall improve energy performance accordingly. This unit has all the controls for the fan in the ceiling vent allowing the user to control, programme and monitor the unit from inside the property. A heater section incorporating a 400w heating element shall be fitted to the fan unit. It shall be electronically controlled so as to minimise energy use. A temperature sensor shall be fitted to the outlet of the heater and will control the output of the heater in an attempt to maintain the set point. The set point will be adjustable between 5°C and 15°C. It also has the ability to be controlled using a RF function and can be boosted from a remote wall mounted switch, remote CO2 detector and an RH sensor.

Once installed, the airflow can be set to suit the house size and, if required, the way it responds to the temperature changes within.

3.0 IMPORTANT NOTES TO INSTALLERS

Successful operation of the fan depends entirely upon the unit being installed strictly in accordance with these instructions. Please read through this guide in its entirety before commencing installation and follow step by step to ensure a satisfactory completion.

Whilst the installation of the DRI-ECO-HEAT-HC unit may be achieved by suitable persons, the provision of the electrical supply and the connection of the unit to the mains must be carried out by a qualified electrician.

Warning: Isolate from power supply before removing any covers. During installation/maintenance ensure all covers are fitted before switching on the mains supply.

This appliance can be used by children aged from 8 years and above and persons with reduced physical, sensory or mental capabilities or lack of experience and knowledge if they have been given supervision or instruction concerning use of the appliance in a safe way and understand the hazards involved. Children shall not play with the appliance. Cleaning and user maintenance shall not be made by children without supervision.

Precautions must be taken to avoid the back-flow of gases into the room from the open flue of gas or other fuel-burning appliances.

Means for disconnection must be incorporated in the fixed wiring as shown in the wiring diagram in accordance with IEE wiring or national wiring rules.

CAUTION: In order to avoid a hazard due to inadvertent resetting of the thermal cut-out, this appliance must not be supplied through an external switching device, such as a timer, or connected to a circuit that is regularly switched on and off by the utility.

4.0 LOFT INSPECTION

Check to ensure that the loft has adequate ventilation. There may be occasions where a loft is so well sealed that additional ventilation may have to be provided by the owner/occupier.

- **Ensure** that all water tanks are covered and sealed.
- **Check** that all water pipes are lagged.
- **Ensure** that any extract fans are discharging to outside and not into the loft.
- **Check** that the loft hatch is tightly sealed.
- **Ensure** that all holes in the ceilings are sealed i.e. ceiling light fittings etc.
- **Check** any flues or chimneys for leakage in the loft via a visual inspection, should be carried out by the installer.
- **If any** leakage points are found, or if there is any doubt at all, then the installer should advise the house owner/provider as soon as possible and seek instruction from them before proceeding with the installation.

5.0 DIFFUSER INSTALLATION

5.1 Siting the Diffuser Position

The diffuser has a unique air throw pattern and it is essential that it is located correctly in the central hallway in single storey properties or in the ceiling of the top floor landing on 2 or more storey dwellings. The diffuser discharges air evenly in all directions along the underside of the ceiling.

Speed Setting	Minimum distance of diffuser from wall
1	100mm
2	155mm
3	400mm
4	625mm
5	850mm
6	1000mm

Note: SMOKE ALARMS -It is also important to ensure that the diffuser is NOT placed within 1 metre of a smoke alarm.

If the diffuser cannot be repositioned, two sides of the diffuser must be closed off using the air dams supplied to encourage the air through the remaining open sides that faces at least 1.5 metres of unobstructed area away from the smoke alarm sensor.

5.2 Fitting the Air Dams (If Required)

Air dams should be fitted as needed, to alter the direction of airflow required. 2 air dams are supplied and will fit on any of the diffuser sides to guide airflow away from a smoke detector and/or obstructions.

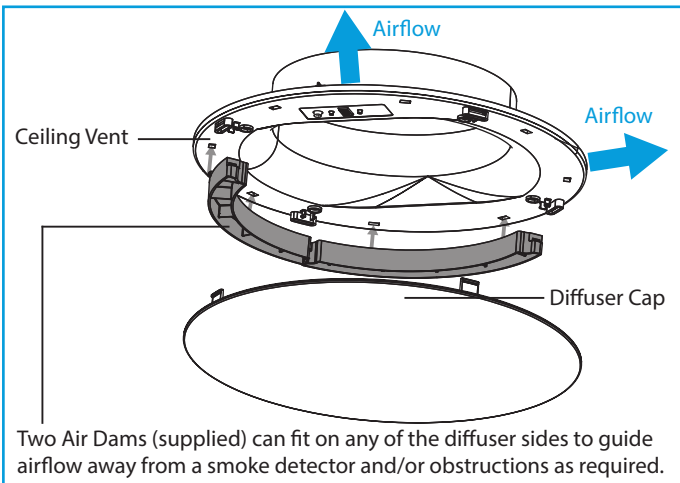

5.3 Fitting the Ceiling Diffuser

To install the diffuser, use the tear-out template from the lid of the unit packaging and trace the shape onto the ceiling between two convenient joists. The shape is elliptical to allow space for the PCB of the controls and this should be positioned for ease of access (i.e. NOT facing over a stairwell). Once the shape has been cut out, position the ceiling and secure it in place using the 4 screws and plugs provided. After fitting attach the diffuser cap to the frame using the four built-in press on clips provided.

6.0 FITTING THE HEATER

The heater unit must be connected to the ceiling vent and fan unit using the 3 looms that protrude from the heater module. Connect the ceiling vent control loom to the circuit board on the ceiling vent and insert the heater module into the ceiling vent. Connect the interconnect loom into the rear of the fan unit. Connect the mains power loom into the power outlet on the underside of the fan unit.

The flexible duct (maximum length 2m) is connected to the base unit by inserting the duct over the outlet duct and held in place using the supplied cable tie.

Finally when installing the duct to the heater unit insert the duct over the back of the heater, over the protruding screw heads (3mm from the face of the duct) and fasten the cable tie below the screws. This ensures that the duct will be held on securely, check all duct joints are air tight.

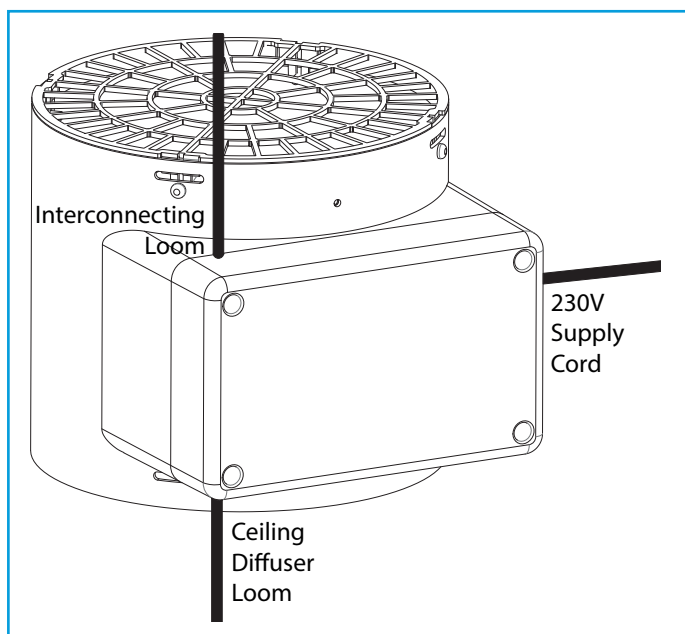

7.0 FITTING THE FILTERS

The filter has a push fit rim to attach itself to the main body of the unit. Offer the filters up to the unit and apply a small amount of pressure to the filters rim (by hand). The filter will clip into place.

The unit can then be attached to the roof via the cord provided (or fixed to the floor joists using the optional anti vibration mounting kit).

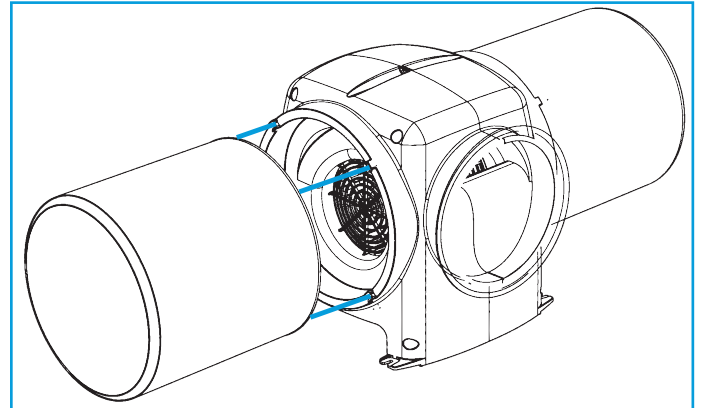

8.0 DRI-ECO-HEAT-HC INSTALLATION

8.1 Joist Hung (Standard Mounting)

The standard method of installation is to suspend from a convenient roof beam via the cord supplied (Note: unit weight = 3.5 kg). The method of locating the cord to the roof timber is the responsibility of the installer.

The flexible duct (maximum length 2m) is connected to the fan unit by inserting the duct over the fan outlet and held in place using the supplied cable tie. This method is repeated when connecting the duct to the ceiling vent. Note: Ensure all duct joints are airtight.

Please note: The flexible ducting should NOT be installed in a compressive state, as this will negatively impact on the performance of the unit.

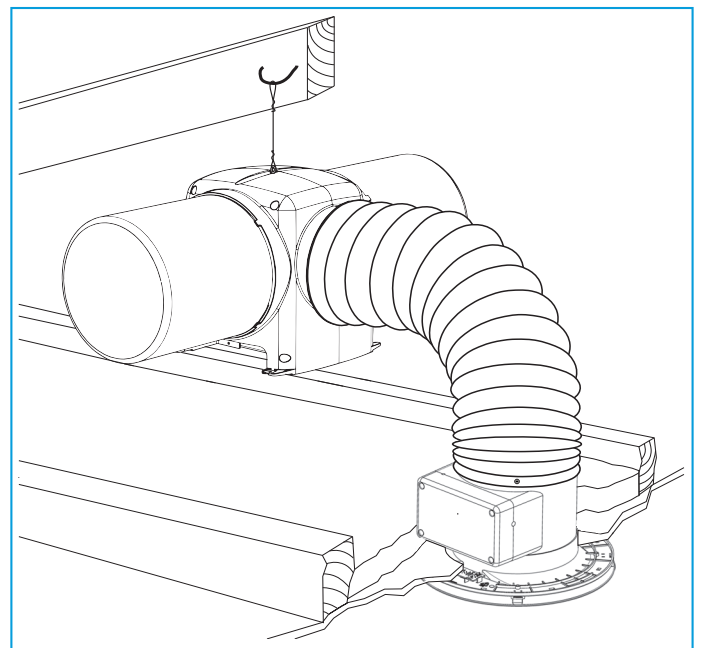

8.2 AV Mounting (Optional)

The AV kit contains all the parts necessary to complete a joist mounted installation. If AV mounting is required, the kit can be purchased direct from Nuair using the following code number: 771393.

Lower the unit with battens (battens are not supplied by Nuair) attached onto the joists. Mark and drill the 12mm diameter clearance holes required in the ends of the battens.

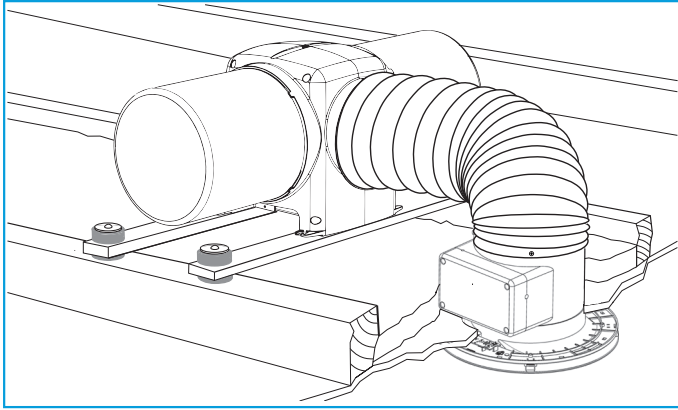

Place anti-vibration mounts above and below each batten fixing point and, using the 4 large screws and special washers, fix the unit to the joists.

Do not overtighten the fixings. The distance from the top washer to the joist when installed must not be less than 50mm.

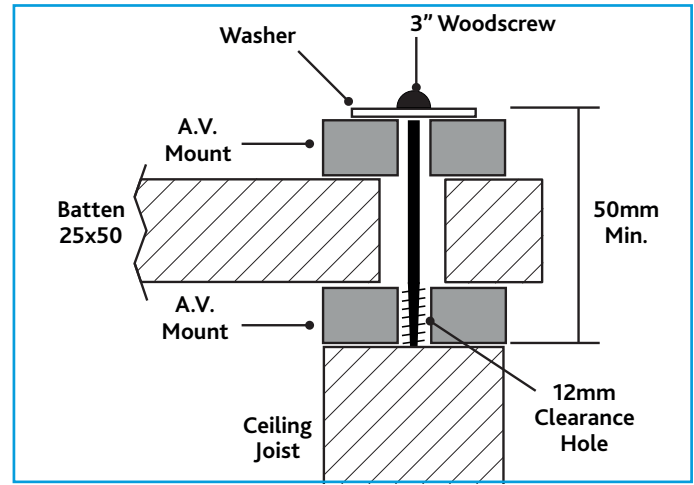

9.0 ELECTRICAL CONNECTION

Please note: the electrical connection of the unit must be carried out by a qualified electrician.

Electrical details

Voltage:	230V 1ph 50Hz
Consumption:	1.6W(min) 15.3W(max) Up to 422W with heater at full load.
Fuse size:	3 Amp

The fan unit is also supplied with a fused spur. The three core mains cable from the fan unit should be connected to a fixed wiring installation, via the spur, in accordance with current IEE wiring regulations.

Disconnection from mains must be incorporated within the fixed wiring and shall have a minimum contact separation of 3mm in accordance with latest edition of the wiring regulations.

9.1 Replacing a Supply Cord

If the mains supply cord to the PSU is damaged, it must be replaced by the manufacturer, its service agent or similarly qualified persons in order to avoid a hazard.

IMPORTANT

For good EMC engineering practice, the DRI-ECO-HEAT-HC power supply output cable and any sensor cables should not be placed within 50mm of other cables or each other.

10.0 SMOKE / CARBON MONOXIDE ALARM AUTOMATIC SHUT DOWN

If the unit is required to switch off in the event of smoke/CO detection, alarms are available with separate relay bases from companies such as:

Kidde – www.kiddesafetyeurope.co.uk

Aico Ltd – www.aico.co.uk

Note: This is a mandatory requirement for all units installed in a 3 Storey property.

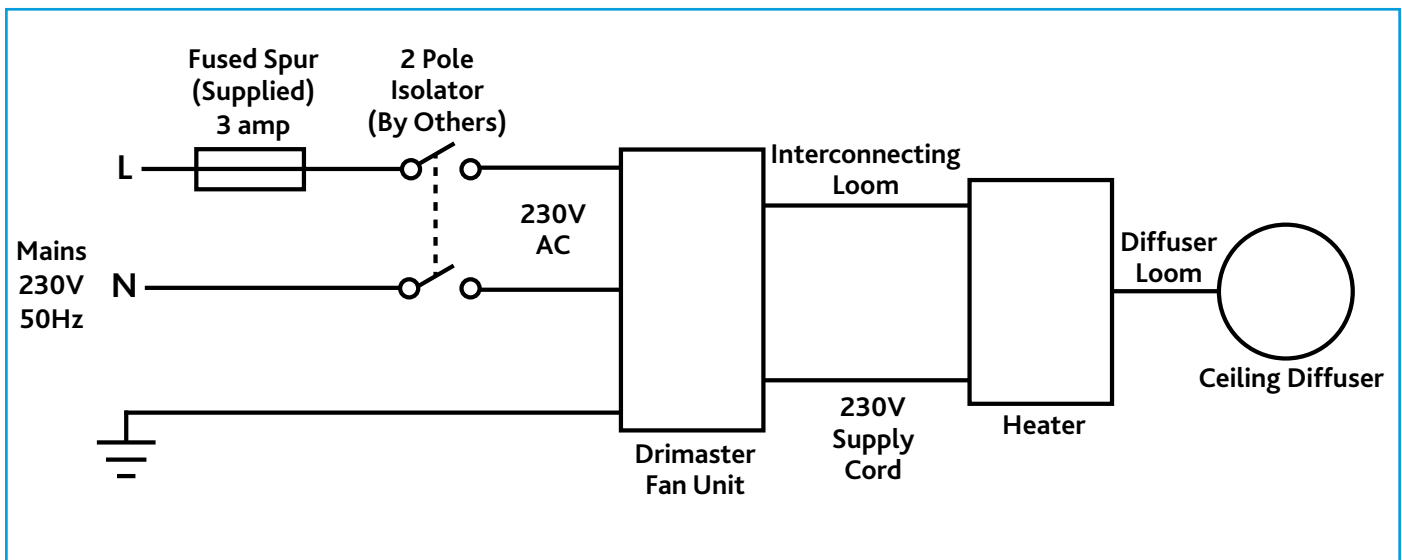

For information only, refer to manufacturer's specific instructions.

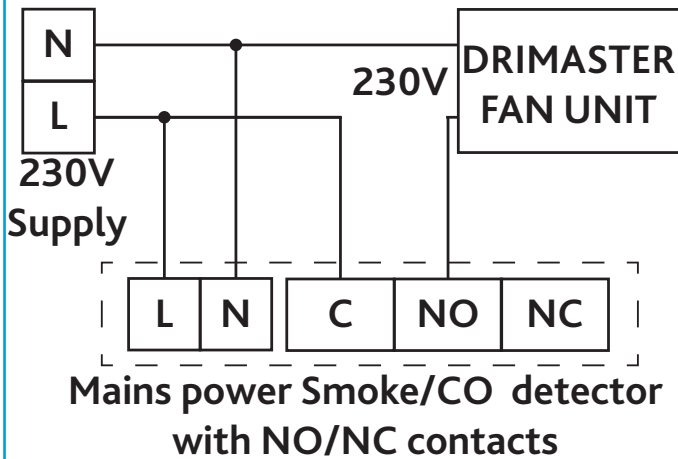

IMPORTANT

In the event of conducted RF interference between 80 to 127 MHz or transient radiated interference between 80 to 87 MHz, the unit may go into standby mode or the LED display may go blank and fan stop temporarily, then go into reset mode (LED flashing with the number of the speed setting) and run at high speed. The unit will return to normal after 2 minutes after the RF interference has stopped.

11.3 Setting the Temperature Set Point

A temperature sensor is fitted to the outlet of the heater and will control the heater output to maintain the set point. The set point ranges between 5°C (fully anti-clockwise) and 15°C (fully clockwise) and can be adjusted via the minimum / maximum commissioning pot located on the ceiling vent diffuser. If the temperature at the heater outlet sensor is above the setpoint, the heater will not activate.

11.4 Setting the Temperature Speed Control Option

When delivered, the unit is set to temperature setting 1 as a default. To change this setting, switch the power to the unit on (via the supplied isolator). The display in the ceiling vent will show the start-up pattern for two minutes and the unit will be running at speed 6. In this time you can change the temperature setting by pressing and holding the "up" switch. The display will show a flashing value of 1 and will increase every 4 seconds. Once you have reached the temperature setting you require press and release the "down" button to store the setting. The fan will now enter into its normal speed setting mode and a speed can be selected at this point.

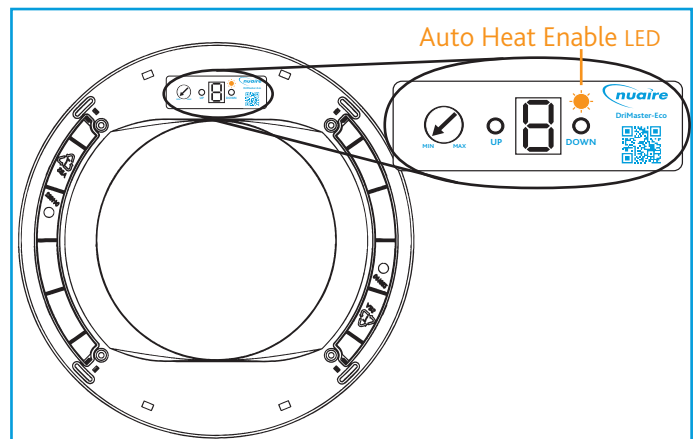

11.0 CONTROL SETTINGS

11.1 Speed Settings

The unit has 5 air flow rate (speed) settings, 2-6. Switches to control the speed settings and the display are located on the underside of the diffuser. The following table shows the flow rates and their corresponding speed settings.

As an example a one bedroom bungalow should be set to speed 2, and a large 5 bedroom detached property would require speed 6.

Speed Settings	Air flow rate (Litres/second)
0	Standby (0)
1	10*
2	20
3	30
4	40
5	50
6	60

* At speed 1 the heater will not be enabled.

11.2 Selecting a Speed

When power to the unit is switched on the display will show the temperature control option for 2 minutes. Once the start-up pattern has completed you may now press the "up" or "down" switch to choose the flow rate appropriate to the property you are installing the unit in.

Option	Temperature Control Description
1 (Default)	At loft temperatures below 19°C the unit will operate on "Normal Operation Mode". At loft temperatures above 18°C but less than 24°C, the unit will switch automatically to "Intelligent Heat Recovery Mode". At loft temperatures above 23°C the unit will switch itself automatically to "Standby Mode".
2	At loft temperatures below 19°C the unit will operate on "Normal Operation Mode". At loft temperatures above 18°C but less than 31°C, the unit will switch automatically to "Intelligent Heat Recovery Mode". At loft temperatures above 30°C the unit will switch itself automatically to "Standby Mode".
3	This option removes the temperature sensing function out of the unit. The unit will operate continuously in "Normal Operation Mode" depending on the volume control setting selected.
4	At loft temperatures below 16°C the unit will operate on "Normal Operation Mode". At loft temperatures above 15°C but less than 28°C, the unit will switch automatically to "Heat Recovery Mode". At loft temperatures above 27°C the unit will switch itself automatically to "Standby Mode".
5	Not applicable for the HEAT model.

12.0 FILTER MAINTENANCE AND REPLACEMENT

The filters are required to be changed every five years, the display will show the letter 'C' once this time has elapsed. New filters can be purchased direct from Nuairé using the following code number: DRIPOS2001-FILTERKIT (five year filter).

To reset the change filter message, press and hold BOTH "up and "down" button until the letter 'C' starts to flash then release and press the "down" button.

Note: If the units' performance has been reduced dramatically or black dust becomes visible around the outlet diffuser, check that the filter has not become dislodged in any way.

13.0 WIRELESS SENSORS & SWITCHES

13.1 Installing a 4 Way Switch (DRI-ECO-4S)

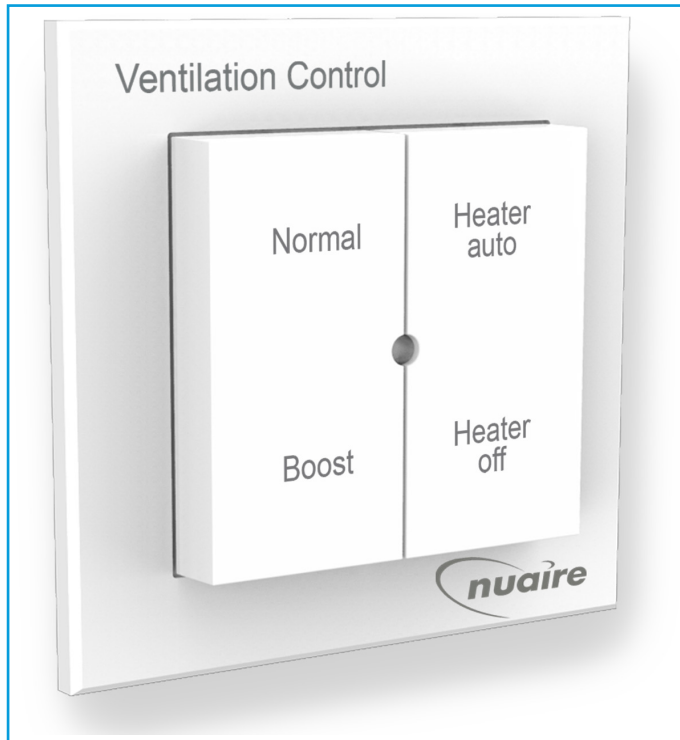

The switch is provided with an adhesive foam pad to allow quick and easy mounting to the wall. Alternatively the switch may be mounted to the wall using the fixing plate (screws are not provided).

Remove the switch fixing plate by inserting a flat head screwdriver in the rear of the switch on the left or right side, underneath the fixing plate and gently lever up the plate until the fixing lug releases. Repeat for the opposite side. This will give access to the battery compartment on the rear of the PCB and release the fixing plate. Reassemble the remaining components and press into place, an audible click will be heard. 1x CR 2032 battery is provided and expected lifetime is 10 years under normal use.

Normal - If the normal button is used the unit will return to its standard operation programmed at the diffuser.

Boost (Purge) - If the boost button is used, the fan speed will increase to maximum and a 'P' will be shown in the display.

Heater auto - If the heater auto button is used, the heater switches on/off automatically as needed.

Heater off - If the heater off button is used 'Heater auto' will be disabled and the heater switches off.

13.2 Installing a Humidity Sensor (DRI-ECO-RH)

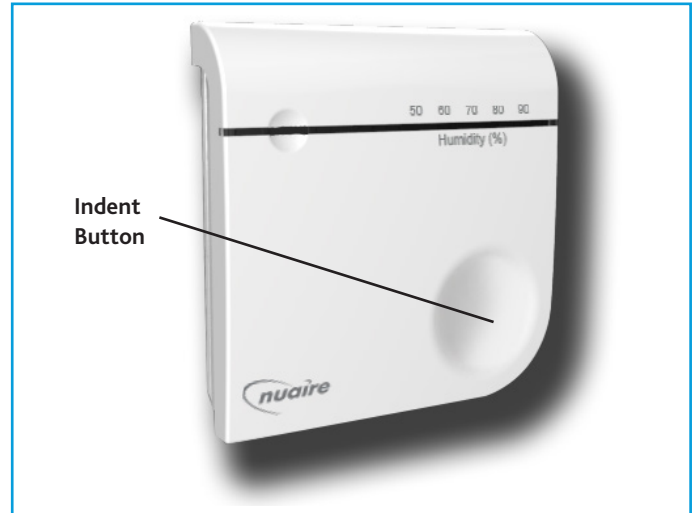

The front panel of the sensor must first be released by pressing in the plastic fixing lug located on the bottom edge of the sensor. The panel may now be removed and the sensor mounted on the wall in a suitable location (screws not provided). 2x AA batteries are provided.

13.3 Installing a CO2 Sensor (DRI-ECO-CO2)

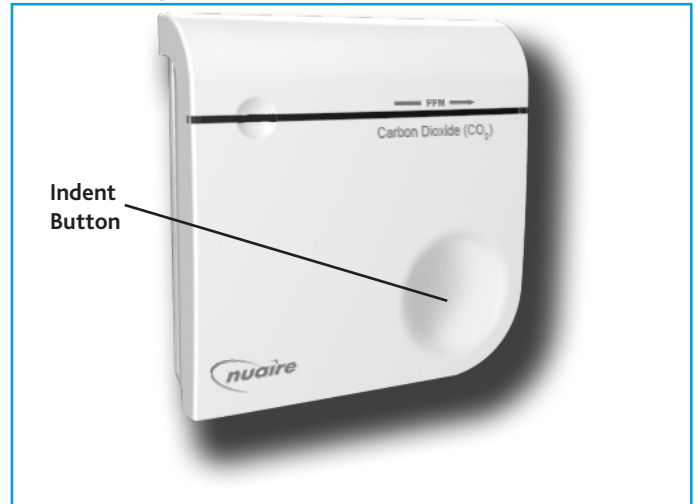

Mains
230V
50Hz
4VA

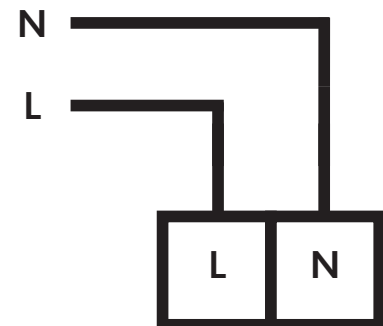

CO2
Sensor

The CO2 sensor requires a 230V power supply. Remove the front panel as per the humidity sensor and release the terminal cover via a fixing lug on the rear of the sensor. Refer to the wiring diagram provided and connect the supply to the terminal box. Finally the sensor may be mounted to the wall (screws are not provided).

13.4 Unit Binding Mode

Where wireless sensors/switches are present, they must first be bound to the fan unit before it can work. In order to bind to the switches/sensors the fan must be in binding mode. The steps required to enter binding mode are shown below.

1. Ensure the fan unit is powered on.
2. Unit will enter the start-up sequence for 2 minutes when first powered on. Press the down button on the ceiling diffuser control panel once, to exit the start-up sequence.
3. Press and hold both the UP and DOWN buttons for between 20-30 seconds then release (optimum time is 25 seconds), a single horizontal bar on the display flashes.
4. Press "down" to enter binding mode (binding mode last for 5 minutes). The unit will now display a flashing 'b' to indicate it has entered binding mode.

Note: Solid "P" indicates boost, flashing "b" indicates binding mode.

13.5 Binding a 4 Way Switch

Once the fan unit is in binding mode a switch may now be bound.

1. Press and hold the 'Boost' & 'Heater off' button for 2-5 seconds.
2. The LED will flash GREEN twice when bound.

To check the binding of a switch, press "boost". A green LED denotes that the switch is bound and the fan should run at full speed. A red LED denotes that the switch is not bound.

Note: if "b" and "P" are flashing on the display, the unit is in binding mode and purge (full speed).

13.6 Binding a Sensor

Putting the unit into binding (see 13.4) before powering the sensors will automatically bind the sensors to the unit. However if they do not bind follow the below steps.

1. Put the unit into binding mode (see 13.4).
2. Power up sensors (insert batteries for humidity, mains for CO2).
3. Tap indented button then hold until left hand LED flashes red/green (ignore red/blue and continue to hold). Release button whilst flashing.
4. Tap indented button again, whilst red/green LED is still flashing.
5. Close binding window on fan control panel by holding both "up" and "down" for 5 seconds and release.
6. Check sensor has bound by tapping indented button and look for the left hand LED to go green. If it displays red, repeat from step 1.

13.7 Setting the Sensor Set Point

The sensors will automatically trigger the fan to increase speed once the sensor set point has been exceeded. To change the sensor set point, press and hold the indent button for 5 seconds until the status indication LED flashes BLUE/RED release, the green LED's illuminate to show the current sensor set point. Press the button to cycle through all allowed values, and press and hold for 3 seconds to confirm choice. If the button is not operated for 10 seconds the set point currently selected is stored.

Once the selected sensor set point has been exceeded for longer than the set point delay (10-30 seconds), the fan unit will increase in speed by 1 and a solid 'b' will be shown on the diffuser display.

13.8 Indicator LED's

The sensors and switches include an LED which illuminates when a button is pressed. A green light shows that communication between it and the fan unit is taking place. A red light shows that no communication is taking place and binding may be required.

16.0 HEATER ON (AUTO HEAT) / OFF CONTROL

When the orange LED on the diffuser control panel is illuminated, the heater is active in autoheat mode and is controlled by the temperature setpoint. When the orange LED is not lit, the heater is off.

IMPORTANT

Heater is enabled only when the orange LED is illuminated.

14.0 FREQUENTLY ASKED QUESTIONS

While very rare, issues with newly installed units can occur. Typically these issues can be easily solved by referring to the below table.

Symptom	Cause	Solution
Fan not running.	NO power to the unit (Display is NOT lit).	Ensure unit has not been switched off or that the local fuse has not blown.
	Software error - Power to the unit (Display is lit).	If electricity present, power off, wait and power on again – this may restart the unit.
	Fan failure - Power to the unit ('F' is flashing on display).	Fan has failed and a replacement unit is required.
	High loft temperature.	This is normal, see temperature control options.

15.0 WARRANTY

The unit has a 7 year warranty starting from the day of delivery and includes parts and labour for the first year. The remaining 6 years covers parts only. This warranty is conditional on the following:

- That the unit is installed strictly in accordance with this guide.
- That the unit filters are removed and cleaned or replaced at the recommended intervals.
- Where a floor/room is more than 4.5m tall, the fan unit must be fitted with a 3 storey aluminium diffuser and requirements in "SMOKE/CARBON MONOXIDE ALARM AUTOMATIC SHUT DOWN" section followed.

This warranty is void if the equipment is modified without authorisation, is incorrectly applied, misused, disassembled, or not installed, commissioned and maintained in accordance with the details contained in this manual and general good practice.

The product warranty applies to the UK mainland and in accordance with Clause 14 of our Conditions of Sale. Customers purchasing from outside of the UK should contact Nuair International Sales office for further details.

17.0 AFTER SALES ENQUIRIES

A QR code linking directly to the Nuaire Ltd. website is located behind the diffuser plate and can be used to order spare parts and replacement components.

For technical assistance or further product information, please contact the After Sales Department.

Telephone 02920 858 400
technicalsupport@nuaire.co.uk