

GATOR ACCESSORIES

Technical Specification

Product Code: OV113WB

Description: Gator Ø76mm Wall Arm Bracket Grey

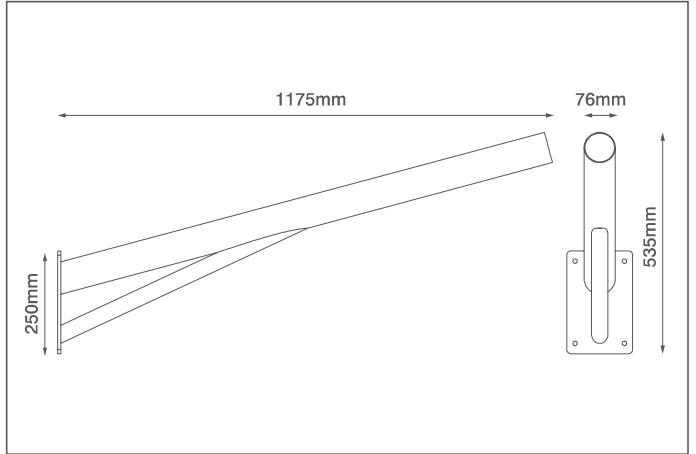
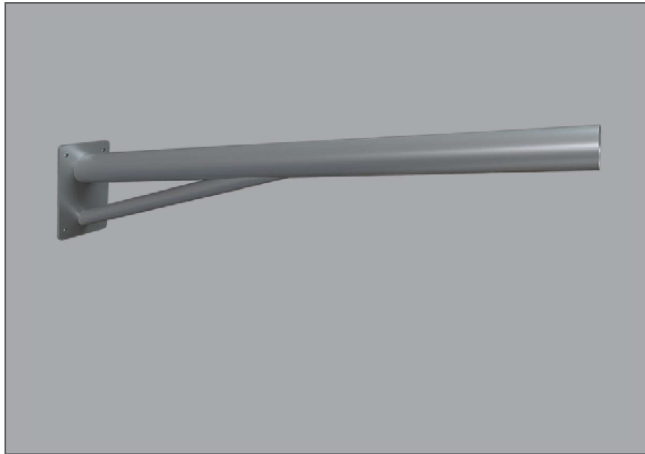

General Information

Dimensions (mm)	1175 (L) x 535 (H) x 76 (Dia.)
Spigot Diameter (mm)	76
Materials	Body: Powdercoated Steel
Finish	Light Grey (RAL 7037)
Product Weight (Kg)	1.8
Warranty (Years)	5



OVIA Limited, Scolmore House, Mariner, Lichfield Road Industrial Estate,
Tamworth, Staffordshire, B79 7UL United Kingdom

T: +44 (0)1827 300640

E: sales@oviaUK.com | W: oviaUK.com