

CONTROLS

Technical Specification

Product Code: OVMS002WHD

Description: Surface Mounted 360° 1-10V Dimmable Microwave Sensor - IP65 - White

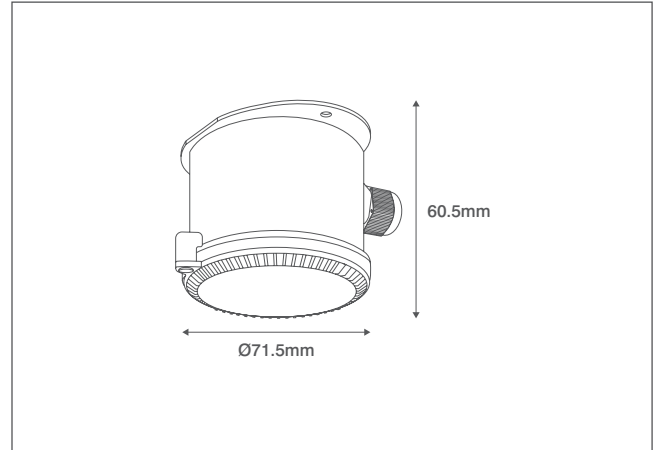

General Information

Dimensions	71.5mm Diameter (90mm Wide With Mounting Base) x 60.5mm
Materials	Body: Polycarbonate (UV Stabilised)
Finish	White
Typical Mounting	Horizontal / Ceiling
Ingress Protection	IP65
Warranty	5 Years

Supply & Power

Input Voltage & Frequency	220-240V~ 50/60Hz
Terminations	Input: Permanent Live & Neutral Cables Output: Switched Live and 1-10V Dimming Cables
Electrical Safety	Class II (Double Insulated)
Load Rating	1000W - LED & Compact Fluorescent 2000W - Incandescent & Halogen
Zero Cross Technology	Yes
Power Consumption	0.9W Approx.
Ambient Temperature (Ta)	-20°C - +40°C

Sensor Parameters & Settings

Installation Height	4 Metres to 15 Metres	
Detection Distance	4 Metre to 10 Metres Radius	
Detection Angle	360°	
Detection Motion Speed	0.6-1.5m/s	
Manual Adjustments (DIP Switches - Set Increments)	Detection Range	50% (5 Metre Radius) & 100% (10 Metre Radius)
	Hold Time	5s, 30s, 90s, 3min., 5min., 10min., 20min. & 30min.
	Stand-by Period	10s, 1min., 5min., 10min., 30min., 60min., +∞ & 0s
	Stand-by Dimmed Period	10%, 20%, 30% & 50%
	Lux Level	2 Lux, 10 Lux, 50 Lux & 2000 Lux

Detection Area Schematics

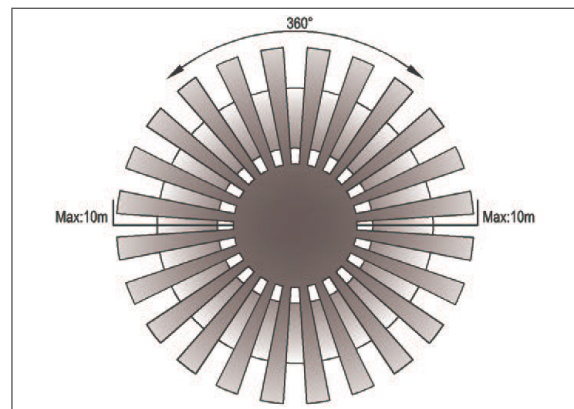
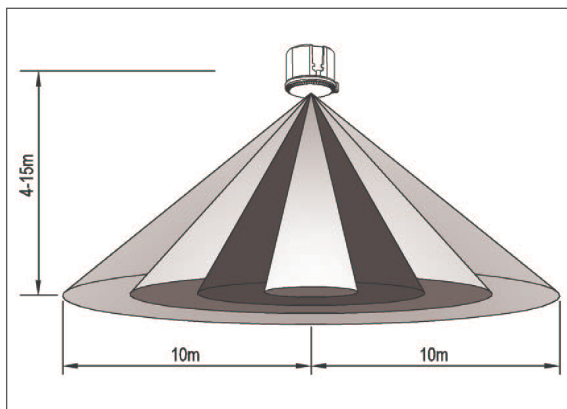

OVIA Limited, Scolmore House, Mariner, Lichfield Road Industrial Estate, Tamworth, Staffordshire, B79 7UL United Kingdom

T: +44 (0)1827 300640

E: sales@oviaUK.com | W: oviaUK.com