

# INCEPTOR® HI-LITE

## Technical Specification

Product Code: OXHL150-M

Description: 150W LED Dimmable Highbay With Microwave Sensor IP65 CTA Black

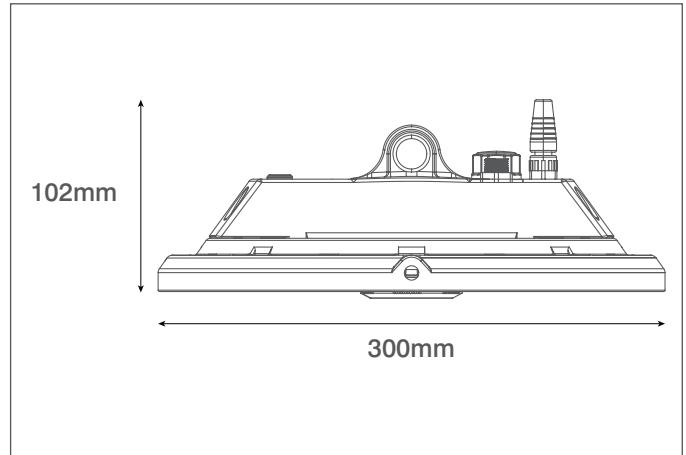

### General Information

Dimensions (mm)	300 (Dia.) x 102 (D)
Materials	Body: Powdercoated Aluminium; Diffuser: Polycarbonate
Finish	Black (RAL 9005)
Product Weight (Kg)	2.8
Ingress Protection	IP65
Impact Rating (IK)	10
Fixing Components Supplied	Suspension Point Within Moulding
Warranty (Years)	6

### Supply & Power Information

Input Voltage & Frequency (V~ / Hz)	220-240 50/60
Safety Class	I
Circuit Wattage (W)	150
LED Wattage (W)	150
Input Current (mA)	542-1000
Inrush Current	75A (288µs)
Power Factor	>0.9
Operating Temperature (°C)	-40 to +50
Minimum Critical Temperature (°C)	-40
Maximum Critical Temperature (°C)	+90
Input Mains Cable	3 x 1mm <sup>2</sup> H05RN-F (3 Metres)

### Luminaire Output

Colour Temperature (K)	4000	5000	6500
Typical Luminous Flux (lm)	23250	24750	22500
Efficacy (lm/W)	155	165	150
Beam Angle (°)	90		
Colour Rendering Index (CRI)	80		
Flicker Free	Yes		
Energy Classification	D		
LED Lifetime (L70) (Hours)	50000		

### Dimming Information

Dimmable	Yes
Dimming Format	Via The Sensor

### Sensor Information

OVCGBIRR required to adjust settings below\*\*

Detection Distance (M)	12
Detection Range Settings (%)	25, 50, 75, 100
Stand-by Dimming Level Settings (%)	10, 20, 30, 50
Stand-by 'On' Period Settings	0s, 10s, 30s, 1min, 5min, 10min, 30min, ∞+
Minimum Detection Angle (°)	30
Maximum Detection Angle (°)	150
Daylight Threshold Settings (Lux)	2, 10, 30, 50, 80, 120, Disable
Default Settings	The microwave sensor is disabled allowing for manual ON and OFF operation.
Hold Time Settings	5s, 30s, 1min, 3min, 5min, 10min, 20min, 30min

### Compatible Accessories

- OWWB1081 - Black Bracket For 150W Inceptor® Hi-Lite Highbay Fitting
- OVCGBIRR - Remote Control For Highbay Fittings With Microwave Sensor
- OHLEMP - 5W 3 Hour Maintained IP65 Emergency Pack
- OEPL05 - Highbay Emergency Pack Coupler Lead 0.5M
- OEPL1 - Highbay Emergency Pack Coupler Lead 1M
- OVHBDACV - IP67 DALI To PWM Signal Converter

### Additional Information

Shorting cap supplied which is removable for emergency pack installation

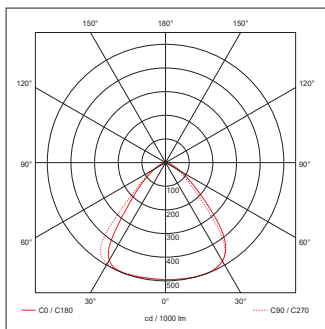

Ovia Limited, Scolmore House, Mariner, Lichfield Road Industrial Estate, Tamworth, Staffordshire, B79 7UL United Kingdom

T: +44 (0)1827 300640

E: sales@oviaUK.com | W: oviaUK.com