

INSTALLATION / WARRANTY INSTRUCTIONS

PRODUCT BRAND: PIERLITE

PRODUCT NAME: Ecobatten G4

PRODUCT CODE: ECOBAT202ECSLSG4, ECOBAT404ECSLSG4, ECOBAT505ECSLSG4
ECOBAT202ECSLSG4M, ECOBAT404ECSLSG4M, ECOBAT505ECSLSG4M
ECOBAT202ECSLSSG4, ECOBAT404ECSLSSG4, ECOBAT505ECSLSSG4

Issue Date: 25 February 2025

Please read these installation instructions carefully before installing or maintaining this equipment. The product is designed for installation and maintenance in accordance with relevant Australian standards (AS/NZ3000), by an authorized and licensed electrician. The installation instructions were correct at the time of print. To reflect changes in technology and Australian and New Zealand standards; Pierlite reserves the right to amend the instructions without notice. Updated guidelines can be found on relevant brand web site.



1. PRODUCT SPECIFICATION:

	ECOBAT202ECSLSG4 ECOBAT202ECSLSG4M ECOBAT202ECSLSSG4	ECOBAT404ECSLSG4 ECOBAT404ECSLSG4M ECOBAT404ECSLSSG4	ECOBAT505ECSLSG4 ECOBAT505ECSLSG4M ECOBAT505ECSLSSG4
Type of Protection	Class I		
Body Material	Steel body with Opal Polycarbonate diffuser		
Finish	Powder coated (RAL9016)		
Circuit Wattage	Please refer to next table		
Nominal Voltage	220-240Vac		
CCT	4000K/5000K/6500K		
Line Current	Please refer to next table		
Nominal Freq. (Hz)	50/60Hz		
Power factor	>0.90		
Inrush current	<8.06A/258us	<15.43A/252us	<27.19A/228us
Leakage current	<0.7mA	<0.7mA	<0.7mA
MCB 16A typeB@230Vac Max. no. of fittings	70pcs	33pcs	21pcs
Rated operating ambient temperature	40 degrees Celsius		
LED lifetime (L80) @ 40 °C	54,000 hours		
Lumen output (lm)	please refer to next table		
IP Rating	IP20 for interior use only		
Suitable for direct mounting on flammable surfaces	YES		
Dimmable	No		
Installation orientation	Surface mounted		
Installation type	Fixed		
Designed application	Interior commercial (Interior)		
Electrical connection	hard wired		
Dimensions	74mm x 74 mm x 603mm	74mm x 74mm x 1164mm	74mm x 74mm x 1500mm
Net Weight of luminaire	0.8 kg	1.51 kg	1.81kg

Warranty years	5 Years (Battery 4 years)
----------------	-----------------------------

The Eco batten are color select and power select batten. Factory settings could be altered accordingly by adjusting the DIP switches on the driver.

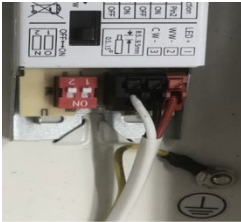

DIP SWITCH	SYSTEM WATTAGE (W)	DRIVER SETTINGS (mA)
1 2		
OFF OFF	18	350
OFF ON	16	300
ON OFF	14	250
ON ON	11	200

ECOBAT202ECSLSG4
ECOBAT202ECSLSG4M
ECOBAT202ECSLSSG4

DIP SWITCH	SYSTEM WATTAGE (W)	DRIVER SETTINGS (mA)
1 2		
OFF OFF	36	350
OFF ON	30	300
ON OFF	25	250
ON ON	20	200

ECOBAT404ECSLSG4
ECOBAT404ECSLSG4M
ECOBAT404ECSLSSG4

DIP SWITCH	SYSTEM WATTAGE (W)	DRIVER SETTINGS (mA)
1 2		
OFF OFF	50	350
OFF ON	45	300
ON OFF	35	250
ON ON	30	200

ECOBAT505ECSLSG4
ECOBAT505ECSLSG4M
ECOBAT505ECSLSSG4

Color select dip switches are located on the driver (CW: 6500K, NW: 5000K, WW: 4000K)



2. CONSUMABLES

Description	QTY Required Per Fitting	Brand	Component Part Number	Dimensions (LxWxH) mm
LiFePO4 battery, 2Cell 6.4V 1500 mAh	1	Pierlite	BATPK1500/2L213W	110*37*21

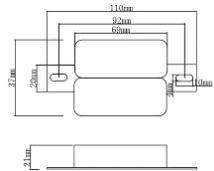

3. INSTALLATION / GENERAL: Installation of the product is to be completed by an authorized and licensed electrician, in accordance with these instructions, relevant Australia standards and local regulations (where applicable). Termination of product wiring, together with the installation of the product must be in a manner and orientation that maintains the integrity of the designated IP rating of the product for electronic control equipment (when supplied) DO NOT MEGGER between A and N.

Line Drawings

ECOBAT202ECSLSG4
ECOBAT202ECSLSG4M
ECOBAT202ECSLSSG4

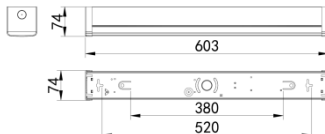

ECOBAT404ECSLSG4
ECOBAT404ECSLSG4M
ECOBAT404ECSLSSG4

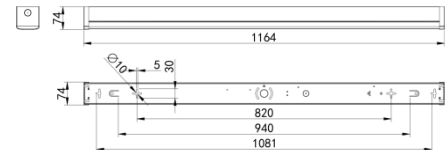

ECOBAT505ECSLSG4
ECOBAT505ECSLSG4M, ECOBAT505ECSLSSG4

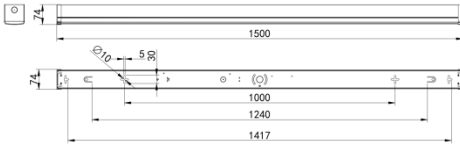

Installation Instructions (Emergency version):

1. Open 2 end caps by using flat screwdriver.
2. Un-tighten phillips screw in one end.
3. Use flat screwdriver to release LED module.
4. Take out LED module & disconnect LED module power cable.
5. Connect wires.

6. Re-connect LED module power cable and connect emergency battery connector. Locate test switch and indicator light on luminaire body. Ensure arrow symbols are in same direction, slide the metal tongue into the slot.
7. Push the other end of LED module to the metal housing until hearing click sound.
8. Tighten phillips screw.
9. Close the end cap.

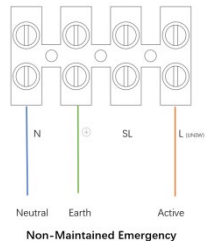
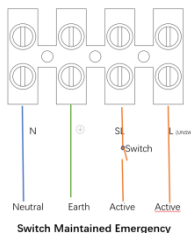
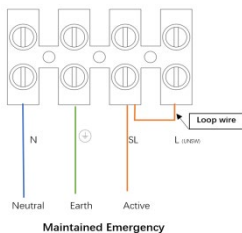

Standard Default Wiring Configuration

Installation Instructions(Standard version, Sensor version):

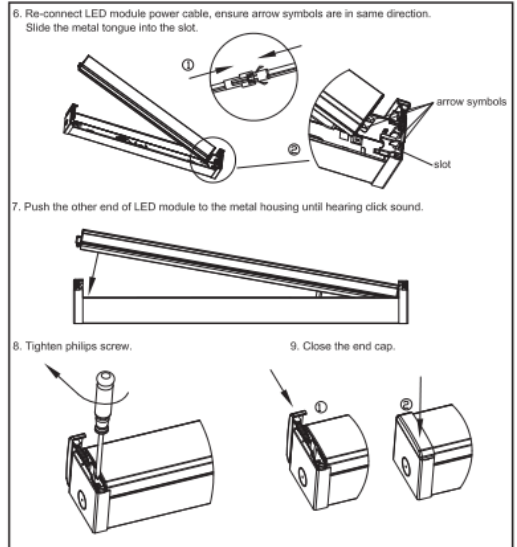
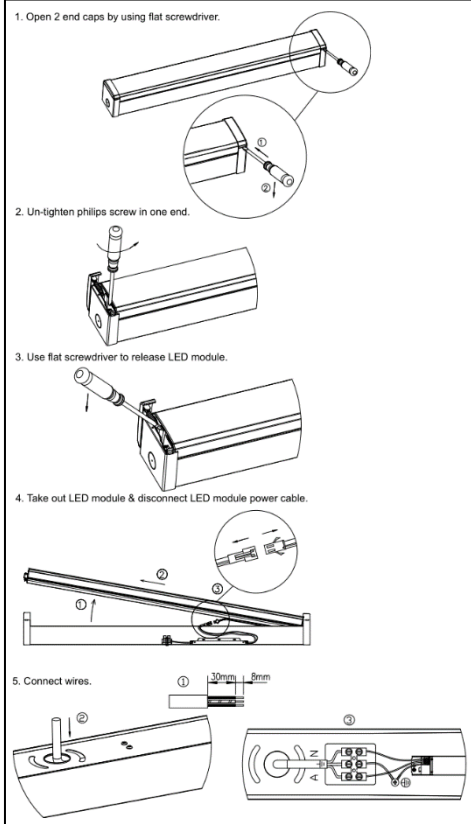

4. Service & Operation (Emergency Version)

Normal Operation: Maintained Emergency Operation.

Battery: Sealed **Lithium Iron Phosphate (LiFePO4)** rechargeable battery pack. As per AS/NZS 2293, it is required that the battery pack is discharged and recharged at least once every 6 months.

In case of a replacement, same brand and type of battery pack must be used. Allow 24 hours charging time before carrying out any discharge tests.

Charge Duration: 16 Hours

Discharge Duration: M2 = 2 Hours for standard emergency or M4 = 4 hours for rail/heavy industry emergency (Initial Test)

Test Switch: If manual test switch pressed, the fixture will operate from its battery supply.

Please ensure battery plug is connected to the inverter battery terminal.

Emergency Classification: ECOBAT202ECSLSG4M C0/C180: D40 & C90/C270: D25
ECOBAT404ECSLSG4M C0/C180: D50& C90/C270: D25
ECOBAT505ECSLSG4M C0/C180: D63 & C90/C270: D40

WARNING: ALL MAINTENANCE, SUCH AS BATTERY CHANGE ON THIS LUMINAIRE, TO BE PERFORMED BY QUALIFIED PERSONNEL ONLY, DE-ENERGISE ALL SUPPLIES BEFORE MAINTENANCE.

WARNING: The light source contained in this luminaire shall only be replaced by the manufacturer or his service agent or a similar qualified person.

5. ELECTRICAL CHARACTERISTICS

SKU to Order	Selectable Wattages by Dip Switches (W)	Emergency Power (W)	Line Current (A)	Power Factor	Emergency 2 hour duration	Factory Default Setting
ECOBAT202ECSLSG4 ECOBAT202ECSLSSG4	18	/	0.08	0.94	No	Yes
	16	/	0.07	0.93	No	
	14	/	0.06	0.92	No	
	11	/	0.05	0.87	No	
ECOBAT404ECSLSG4 ECOBAT404ECSLSSG4	36	/	0.16	0.94	No	Yes
	30	/	0.14	0.94	No	
	25	/	0.12	0.92	No	
	20	/	0.09	0.91	No	
ECOBAT505ECSLSG4 ECOBAT505ECSLSSG4	50	/	0.22	0.96	No	Yes
	45	/	0.19	0.96	No	
	35	/	0.16	0.95	No	
	30	/	0.13	0.92	No	
ECOBAT202ECSLSG4M	18	2.5	0.09	0.94	Yes	Yes
	16	2.5	0.08	0.93	Yes	
	14	2.5	0.07	0.92	Yes	
	11	2.5	0.06	0.87	Yes	
ECOBAT404ECSLSG4M	36	2.5	0.17	0.94	Yes	Yes
	30	2.5	0.15	0.94	Yes	
	25	2.5	0.13	0.92	Yes	
	20	2.5	0.10	0.91	Yes	
ECOBAT505ECSLSG4M	50	2.5	0.23	0.96	Yes	Yes
	45	2.5	0.20	0.96	Yes	
	35	2.5	0.17	0.95	Yes	
	30	2.5	0.14	0.92	Yes	

6. LUMEN SELECT (contractor selectable output)

Pierlite’s lumen select products allows all licensed electricians to purchase one luminaire that can be set as multiple fixed wattages/fixed lumen outputs. By offering this capability within one fitting it provides the following benefits

- One fitting multiple fixed outputs

- Less stocked items
- One fitting on the shelf or in the van
- Variable onsite options
- Easy to change settings
- IES files available for all available wattages shown in the below table
- No control system or software required to change fixed output

ECOBAT202ECSLSG4, ECOBAT202ECSLSG4M, ECOBAT202ECSLSG4

System Wattage(W)	Driver settings(mA)	4000K (lm)	5000K (lm)	6500K (lm)
18W	350	1900	2100	1900
16W	300	1600	1800	1600
14W	250	1400	1600	1500
11W	200	1100	1200	1100
2.5W (EM)	/	/	/	300

ECOBAT404ECSLSG4, ECOBAT404ECSLSG4M, ECOBAT404ECSLSG4

System Wattage(W)	Driver settings(mA)	4000K (lm)	5000K (lm)	6500K (lm)
36W	350	4000	4400	4000
30W	300	3500	3800	3500
25W	250	3000	3200	3000
20W	200	2300	2500	2300
2.5W (EM)	/	/	/	350

ECOBAT505ECSLSG4, ECOBAT505ECSLSG4M, ECOBAT505ECSLSG4

System Wattage(W)	Driver settings(mA)	4000K (lm)	5000K (lm)	6500K (lm)
50W	350	6900	7200	6800
45W	300	6000	6300	6000
35W	250	5000	5200	5000
30W	200	4200	4300	4200
2.5W (EM)	/	/	/	450

7. IMPORTANT - the product must be maintained and operated in accordance with the manufacturer's instructions, failure to do so may damage the product and services. It is strongly recommended that this important note be communicated to the owner and operator of the installation at the time of site commissioning. Good practice does not recommend the 24/7 use of products without the application of suitable switch cycle intervals. Furthermore, with the omission of nominated survival curves and or recommended operating hours, product design expectations provide for a continual daily usage of 6 hours for residential applications and a continual daily usage of 12 hours for commercial and industrial applications. All products must be thoroughly cleaned on a regular basis at intervals that reflect in the installation environment, ensuring the optical performance, together with the electrical, mechanical, and structural integrity as designed, is maintained throughout the service life of the product.

- 8. APPROVALS:** The RCM marking of this product applies to AS/NZS CISPR15 (EMC) “Limits and methods of measurement of radio disturbance characteristics of electrical lighting and similar equipment”.
 This product is designed to conform to AS/NZS60598 “Luminaires, general requirements and tests”.

9. STORAGE: Prior to installation products are to be stored in cool and dry conditions.

10. APPLICATION: The installation application and orientation of the product is designed in accordance with the nominated product IP rating, class designation and these installation installations. Installation environments outside these conditions are not recommended.

11. MAINTENANCE:

(a) The supply must be isolated before opening or accessing the luminaire. Product maintenance is IMPORTANT and is critical to the products designed performance. The product is to be maintained in accordance with the manufacturer’s instructions. For the latest product maintenance guides please go to relevant brand web site. Pierlite is not responsible for any product not maintained in accordance with the recommended procedure or intervals.

(b) Lamps (where provided): The product is designed with the supplied (LEDs) / LAMP/s and it is strongly recommended that any LAMP / (LEDs) changes (if any) be made in accordance with the type, colour and brand supplied. For recommended LAMP / LED maintenance or operating guides (inclusive of recommended product switch cycles and mandatory run-in procedures for HID and Fluorescent lamps when used with dimming circuits), Pierlite recommends the application of the lamp manufacturer’s operating guidelines, which can be found on manufacturer’s website. Pierlite is not responsible for the product performance of alternative lamp/s used. As a member of FluroCycle, we encourage recycling of lamps and components.

(c) Battery (where provided): The battery is designed with a rated average battery design life in standby mode, and is supported with a standard warranty (refer to product specifications for details); conditional of the product being maintained and operated in accordance with the manufacturer’s guidelines and tested in accordance with AS/NZS2293. For guidelines see product installation instructions or visit the relevant brand web site.

(d) For products supplied with glass visors or covers, do not operate the product with a damaged visor or cover; it is recommended the product be turned off, area surrounding the product vacated, and the damaged glass replaced by a professional installer immediately.

(e) Cables or cords (where provided): If any external cable or cord of the X or Y type luminaire is damaged, it shall be replaced by a qualified person or manufacturers service agent.

For Z type attachments to luminaire, cord cannot be replaced if damaged, the luminaire shall be removed from service.

Flex cord types

- X: Specially prepared flexible cable or cord, may also include a part of the luminaire and only available from manufacturer.
- Y: Attachment may be used with either an ordinary or special flexible cable/cord.
- Z: Attachment of cable/cord that cannot be replaced without damage to luminaire

12. WARRANTY INSTRUCTIONS: For purpose of warranty claims (if any) the following instructions apply:

Warranty period - The above components are provided with a warranty (refer to product specifications for details) against manufacturing defects or failure to perform to specifications for products installed by an authorised installer in accordance with the manufacturer’s installation instructions and which have not been subject to incorrect operation or maintenance, unauthorised modification or damage arising from any intervening cause.

Warranty reference - The warranty reference date commences from the date of purchase.

Warranty point of contact – Signify, Level 9, 5 Rider Blvd, Rhodes, Sydney, NSW 2138, phone T 1300 799 300 – Signify Customer Service.

Warranty claim procedure – For the purpose of making a claim the customer must:

1. Contact the “point of contact” above and upon provision of proof of purchase the customer will receive a goods return advice (GRA) number. 2. At the customer’s expense, collect and return the goods to the “point of contact” with the issued GRA number.
3. Upon receipt of the goods, Pierlite will review the claim and if found to be accepted, Pierlite will return a replacement product to the customer to install at the customer’s expense. Alternatively, if the claim is rejected, the customer may request the return of the goods at their expense.

Consumer Contracts - The benefits to the customer given by the Pierlite warranty are in addition to other rights and remedies of the customer if the goods are the subject of a Consumer Contract under the Australian Consumer Law. In that event the following statement is required to be brought to the Consumer’s attention: - *Our goods come with guarantees that cannot be excluded under the Australian Consumer Law. You are entitled to a replacement or refund for a major failure and for compensation for any other reasonably foreseeable loss or damage. You are also entitled to have the goods repaired or replaced if the goods fail to be of acceptable quality and the failure does not amount to a major failure.*

Limitation of Liability – if the goods are not purchased by the customer under a Consumer Contract within the Australian Consumer Law then but not otherwise;- (a) the Company is not liable in tort for any loss or damage suffered by the customer or by any third

party; and (b) in no circumstances is Pierlite liable to the customer or to any third party for any loss of profits, loss of anticipated savings, economic loss or interruption of business or for any indirect or consequential loss (Consequential Loss).

Terms of Sale – these warranty provisions are in substitution for any inconsistent provisions in the Pierlite Terms and Conditions of Sale in so far as they apply to the warranty components.

ECO LED Batten sensor model are integrated with non-dimmable motion sensor. Sensor specifications are listed below. Factory settings could be altered accordingly by adjusting the DIP switches on the sensor.

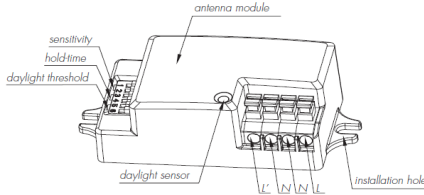

Factory setting

Sensitivity - 100%
 Hold Time - 5 minutes
 Daylight Sensor - Disabled

Factory settings could be altered accordingly by adjusting the DIP switches on the sensor

Adjustable Sensor Setting

Sensitivity: 10%/50%/75%/100%
 Hold Time: 5s/90s/5 minutes/15 minutes
 Daylight Sensor: 2lux/10lux/50lux/Disabled
 Microwave Frequency: 5.8GHz +/-75MHz
 Detection Range Maximum (diameter x height): 10m x 6m
 Detection Angle: 30° -150°

Detection Range

Using High Frequency sensor technology, this unit can sense motion through the body of the light fixture.

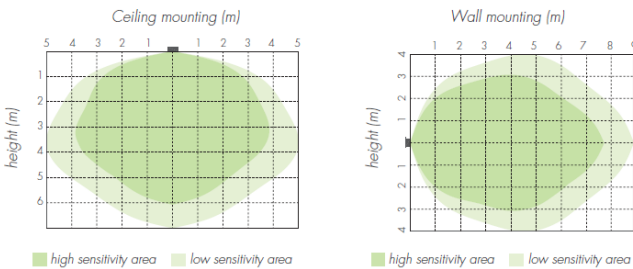

Adjusting the settings

1. Sensitivity

Sensitivity can be adjusted by selecting the combination on the DIP switches for different applications.

- I – 100%
- II – 75%
- III – 50%
- IV – 10%



	1	2	
I	●	●	100%
II	●	○	75%
III	○	●	50%
IV	○	○	10%

2. Hold-time

Holdtime refers to the time period that the light remains 100% on if no more movement is detected.

- I – 5s
- II – 90s
- III – 5min
- IV – 15min



	3	4	
I	●	●	5s
II	●	○	90s
III	○	●	5min
IV	○	○	15min

3. Daylight sensor

Different daylight threshold can be preset on DIP switches. Light will always turn on upon movement if daylight sensor is disabled.

- I – Disable
- II – 50Lux
- III – 10Lux
- IV – 2Lux



	5	6	
I	●	●	Disable
II	●	○	50Lux
III	○	●	10Lux
IV	○	○	2Lux