

Product Data Sheet



Product Code:	Issue No.	Issue Date:	Issue by:
CBX124/I250	B	03/07/2017	T. Tombs

Description:

250A 12W + 4W combined TP mcb board. 12 ways max. 63A. 4 ways 80A, 100A or 125A type C mcb only.

General Characteristics

Standards.	BS EN 61439-1 & 3.
Current rating.	250A.
Voltage rating.	230 / 400V a.c.
Fault current rating	10kA Icc.
Enclosure.	1.6mm cold rolled steel with an epoxy paint finish to RAL7035 matt grey. Bolted construction to BS EN 61439:Pt1 & 3:2011
IP Rating.	IP 3X
Pollution degree.	3
No of poles.	3 + neutral
Incomer terminal capacity.	Tunnel terminal 120mm.sq.
Incomer terminal tightening torque.	6 Nm.
Cable entry facility.	Top & bottom endplates removable for ease of cutting.
Covers / Door.	Screw fixed covers. Hinged door (removable) c/w metal turn catch over outgoing breakers.
No of Outgoing TP mcb ways.	12 up to 63A + 4 – 80A, 100A or 125A.
Equipment type.	Fixed stationary
Approx. weight.	49 kg



Switchgear Fitted

Device	Rating
TP isolator incomer – MC250TNA	250A



General Device Specification – Outgoing Switchgear ordered separately

MCB's:	6A to 40A (10kA) and 50A, 63A (6kA) SP & TP. 230/400V ac. Terminal capacity 25mm sq. to BSEN 60898. 80A, 100A, 125A SP & TP Type C 10kA 230/400V ac. Terminal capacity 50mm sq. to BS EN 60898. Please refer to Device data sheet for further information. Key lock available for outgoing door – product code – XLKL . Clear door available – add / CD to end of product code.
---------------	--

Product Data Sheet



Product Code: CBX124/I250	Issue No. B	Issue Date: 03/07/2017	Issue by: T. Tombs
-------------------------------------	-----------------------	---------------------------	-----------------------

Description

250A 12W + 4W combined TP mcb board. 12 ways max. 63A. 4 ways 80A, 100A or 125A type C mcb only.

Key Dimensions

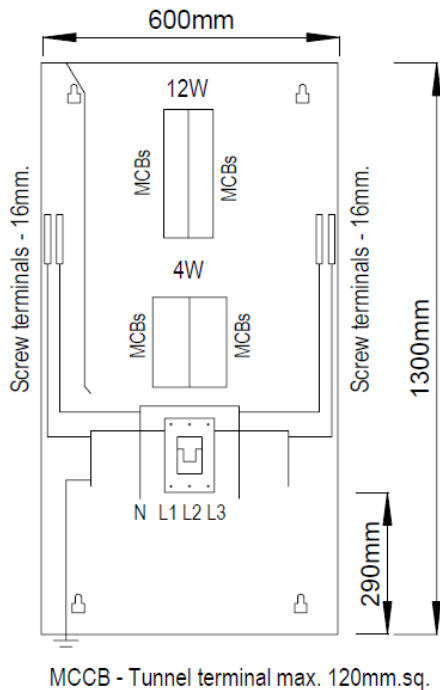

Mounting hole positions

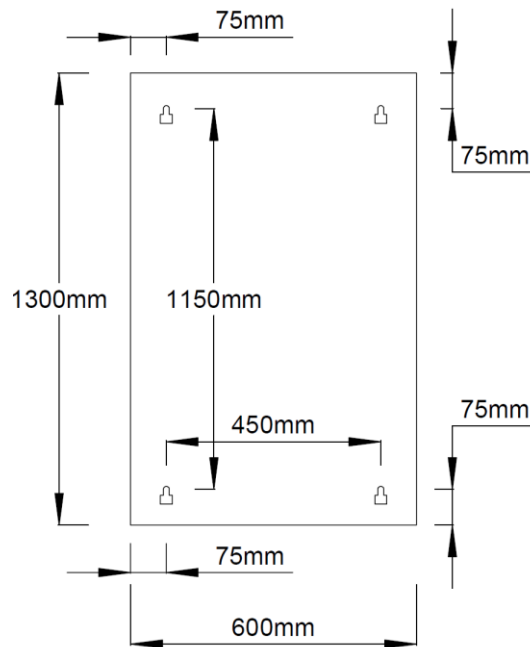

Wall fixing hole

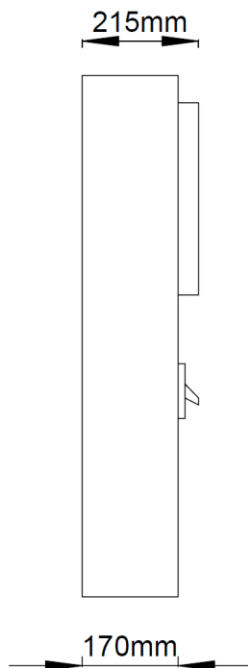
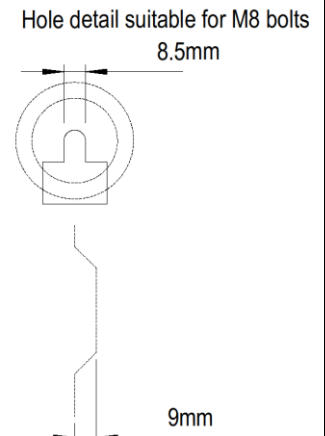

Additional information.

Usage

Intended for use by skilled persons or instructed persons.

Electrical

Earth & Neutral main bar - M8 bolts – tightening torque 20Nm.

Side moulded bars – 16mm.sq. max. - tightening torque 1.7Nm.

Rated frequency: 50/60Hz.

Rated operational voltage: 230/400V a.c.

Rated insulation voltage: 250/440V a.c.

Earthing system: Suitable for use with TN-S, TN-C-S and TT systems.

Insulated gland plates available on request.

EMC environment: Environment type A.

Physical

Ambient operating temperature -5 to 40 °C

(Not exceeding average of 35 °C in any 24 hour period).

Maximum altitude 2000m.

Enclosure: Enclosed assembly galvanised base and internal steel work, external steel work (sides, end, covers and doors) powder coated in hardwearing epoxy matt light grey paint to RAL 7035.

Installation

Service conditions: Wiring of this product must comply with current IEE regulations. Units are intended for indoor use and dry conditions and **NOT** where high levels of humidity and temperature are experienced.

Note: IP rating of enclosures can be compromised if correct use of glands is not followed when installing unit.