

# Product Data Sheet



Product Code: <b>CO/632</b>	Issue No.	Issue Date:	Issue by:
SCL	<b>A</b>	04/11/2016	T. Tombs.

## Description:

Manually operated, 63A, 2 pole changeover switch.

## General Characteristics

Standards.	IEC / EN 60947-3
Current rating.	63A AC-21 18 kW AC-3
Voltage rating.	230V ac
Mechanism.	2 position and Off. Not padlockable.
Enclosure.	Polycarbonate. Lid - 100% Polycarbonate. Base – 90% Polycarbonate with 10% glass.
IP Rating.	65
Pollution degree.	3
No of poles.	2, switched.
Terminal capacity.	35mm.sq.
Terminal tightening torque.	3 Nm
Cable entry facility. Knock outs.	4 x M25/32. 2 in rear, 2 in top, 2 in bottom. 2 x M20, 1 top, 1 bottom.
Covers / Door.	Screw on cover. Captive cover screws.
Equipment type.	Fixed stationary
Weight.	1.47 kg



## Terminal numbers.

Input:

Supply 1: L-1, N-5. Supply 2: L-3, N-7.

Common: 2 & 4. 6 & 8.

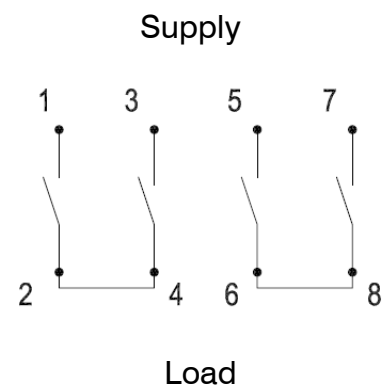

## Switchgear Fitted

Device	Rating
2 pole changeover switch	63A

No accessories available.

# Product Data Sheet



Product Code: **CO/632**

Issue No.

Issue Date:

Issue by:

**A**

04/11/2016

T. Tombs.

**Description:** Manually operated, 63A, 2 pole changeover switch.

## Key Dimensions

## Mounting hole positions

Depth over handle – 194mm

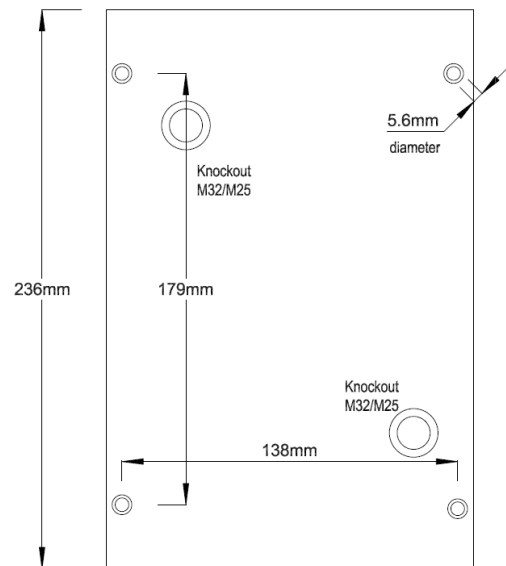
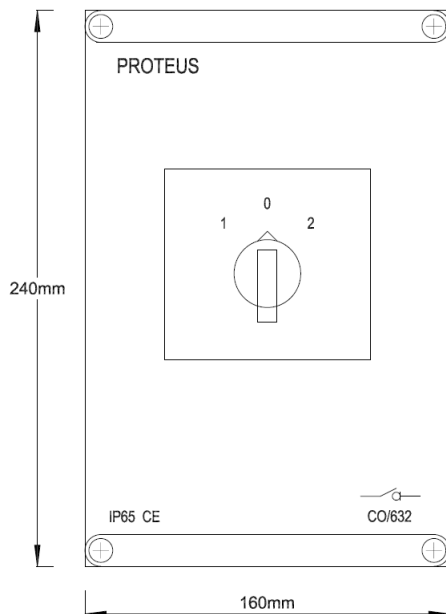

## Additional information.

### Usage

Intended for use by skilled persons or instructed persons.

### Electrical

Earth & Neutral terminals

Rated frequency: 50 / 60Hz.

Rated operational voltage: 230V ac

Rated insulation voltage: 690V

Earthing system:

EMC environment: Environment type A.

### Physical

Ambient operating temperature -5 to 40 °C

(Not exceeding average of 35 °C in any 24 hour period).

Maximum altitude 2000m.

Enclosure: Polycarbonate.

### Installation

Service conditions: Wiring of this product must comply with current IEE regulations. Units are intended for indoor use and dry conditions and **NOT** where high levels of humidity and temperature are experienced.

Note: IP rating of enclosures can be compromised if correct use of glands is not followed when installing unit.