

Product Data Sheet



Product Code: MCEL160T	Issue No. A	Issue Date: 01/12/2016	Issue by: T. Tombs
-------------------------------	-----------------------	---------------------------	-----------------------

Description
160A 3 pole mccb with bolted neutral link mounted in a mild steel enclosure.

General Characteristics	
Standards.	BS EN60947-1 & 2. IEC 60755, IEC 62020, IEC 61543.
Current rating.	160A
Voltage rating.	230 / 400V ac. 50/60Hz.
Fault current Rating.	36kA.
Enclosure. Dimensions	Mild steel to IP3X. 700mmH x 300mmW x 170mmD.
Finish	Matt grey to RAL 7035, Electrostatically applied.



IP Rating.	3X
No of poles.	3 switched, bolted neutral.
Incomer terminal capacity.	Phases – tunnel, max. 120mm.sq. 4mm allan key. Neutral – M8 bolt.
Incomer terminal tightening torque.	Mccb – 6Nm. Neutral – 20Nm.
Cable entry facility.	Plain plate top and bottom. Drill to suit on site.
Covers / Door.	Front bolt on cover.
Earth leakage relay settings. Adjustable.	Milli amp – 30, 100, 300, 500. Amps – 1, 3, 5, 10, 20, 30. Time – mS 0, 60, 150, 250, 500, 800. Sec – 1, 2.5, 5, 10.
No time delay at 30mA	0 – no intentional delay.
E/L CT diameter.	70mm internal diameter.
Equipment type.	Fixed stationary
Weight.	12.62 kg

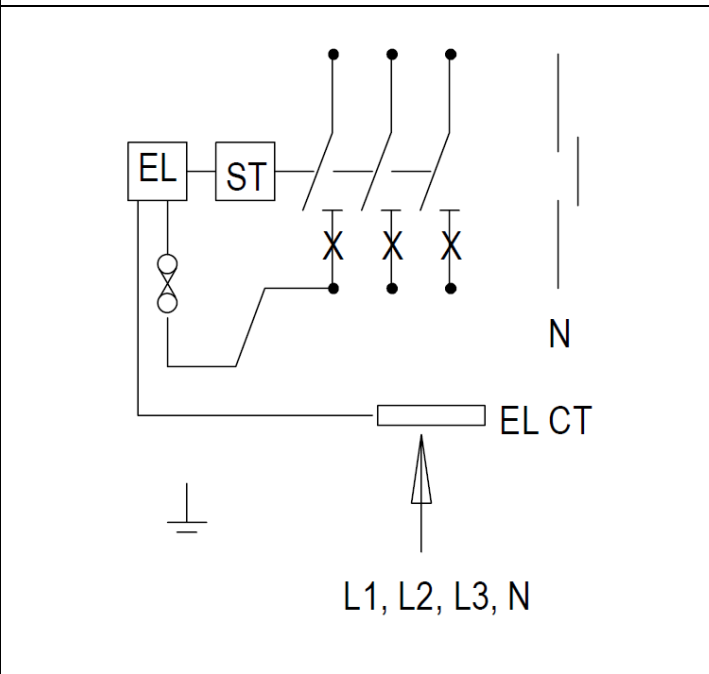

It is intended that this device is under the supervision of an instructed or skilled person as defined by regulation 531.2.6 (ii) of the IEE Wiring Regulations.

Switchgear Fitted	
Device	Rating
MC160T	160A

MCCB: For full technical details of the mccb request MCCB data sheet.

Accessories.
Padlock device: Part no. **MCPD** (padlock not supplied).

Product Data Sheet



Product Code: **MCEL160T**

Issue No.

Issue Date:

Issue by:

A

01/12/2016

T. Tombs

Description

160A 3 pole mccb with bolted neutral link mounted in a mild steel enclosure.

Key Dimensions

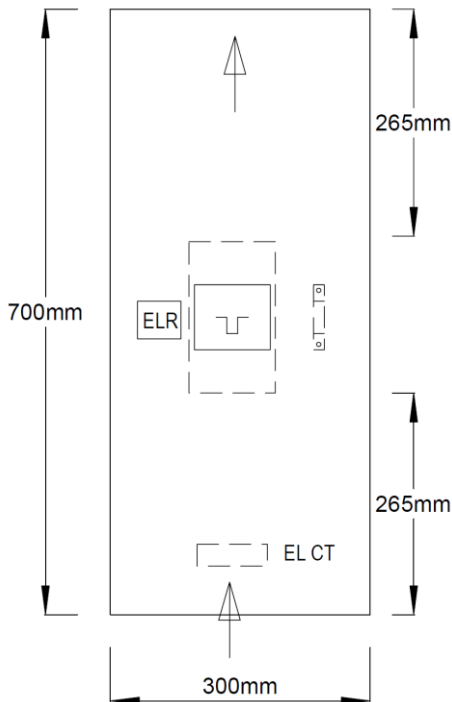

Mounting hole positions

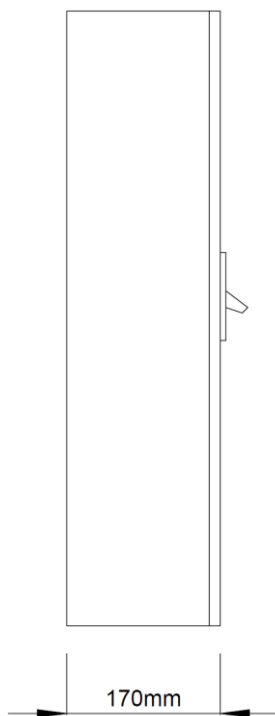
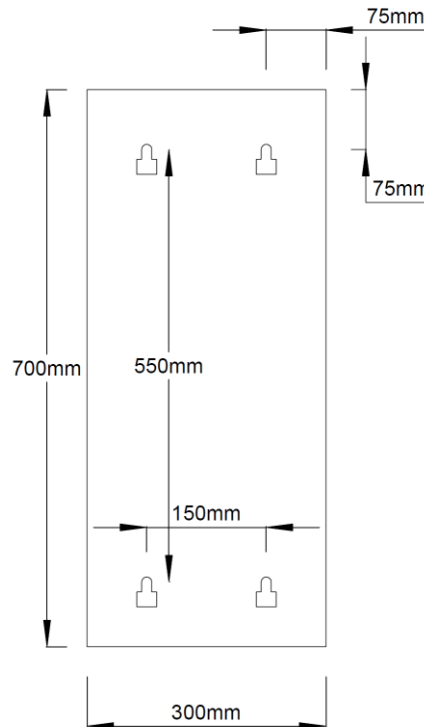

Additional information.

Usage

Intended for use by skilled persons or instructed persons.

Electrical

Earth terminal : Earth bolt M10.

Rated frequency: 50Hz.

Rated operational voltage: 400V

Rated insulation voltage: 750V.

Earthing system:

EMC environment: Environment type A.

Physical

Ambient operating temperature -5 to 40 °C

(Not exceeding average of 35 °C in any 24 hour period).

Maximum altitude 2000m.

Earth Leakage relay

Power on LED.

Earth leakage indication displayed in LED array (% leakage of setting).

Installation

Service conditions: Wiring of this product must comply with current IEE regulations. Units are intended for indoor use and dry conditions and **NOT** where high levels of humidity and temperature are experienced.

Note: IP rating of enclosures can be compromised if correct use of glands is not followed when installing unit.